

PACKAGING EQUIPMENT

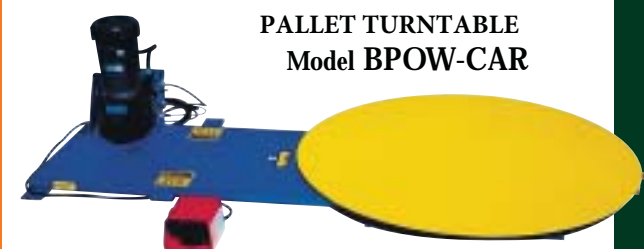

STRETCH WRAP MACHINE
Model BSWA-48



PALLET TURNTABLE
Model BPOW-CAR

AUTOMATIC STRAPPING MACHINE
Model BS-2001



From Stretch Wrapping to Carousels to Strapping Machines your packaging equipment needs are covered. We offer a variety of products that assist in packaging whether by machine or done manually. Increase productivity in your shipping area with Packaging Equipment. Special sizes available.

SEMI-AUTOMATIC STRETCH WRAP MACHINE

- LOW PROFILE DESIGN
- 90V DC, 1/2 HP VARIABLE SPEED DRIVE
- COUNTERBALANCED FILM DISPENSER
- POWERED MAST AVAILABLE

POWERED CAROUSEL

- 4,000 POUNDS CAPACITY
- VARIABLE SPEED CONTROL
- 48" DIAMETER TREADPLATE DECK

SEMI-AUTOMATIC STRAPPING MACHINE

- STAINLESS STEEL DECK
- PORTABLE FOR CONVENIENCE
- EASY ACCESS CONTROL PANEL



PALLET SHRINK WRAP
Model BSW-HAND-R



CORNER PROTECTORS
Model BEDGE

Beacon Industries, Inc.
12300 Old Tesson Rd.
St. Louis, MO 63128-2247 USA
Phone: (314) 487-7600 Fax: (314) 487-0100
beacontechnology.com
E-Mail: sales@beacontechnology.com

Stretch Wrap Machine

Increase productivity in the shipping department or at the end of a production line with the Semi-Automatic Stretch Wrap Machine. This unit is complete with a 48" diameter powered turntable and counter-balanced stretch film mast (turntable available in diameters up to 60"). Easy to operate, simply depress the foot pedal and manually move the mast up and down. Powered by a 115V, using a 90V DC, 1/2 HP motor with soft start/stop and variable speed control.

The Approach Ramp option allows the operator to load and unload the machine with a pallet jack.

The Powered Mast option is available with a 24V hand control to work with those taller loads. When using, depress on either the up or down button to control the height of the film, while depressing on the foot control. Capacities up to 5,000 lbs. Units come standard with two film rods, 15" and 25" to accommodate 10" and 20" material. Optional rods available.

Model BSWA-48



115 V, 1/2 HP Motor

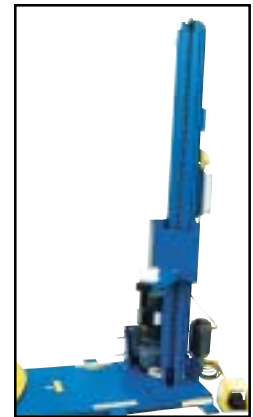

Optional Powered Mast
(add suffix -PMO)

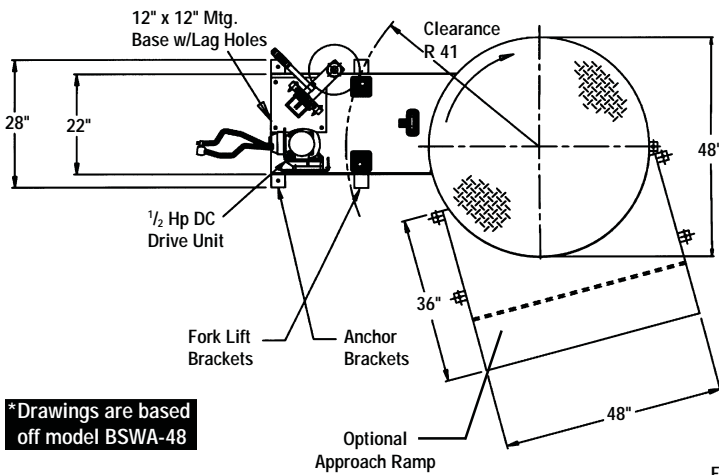

*Drawings are based off model BSWA-48

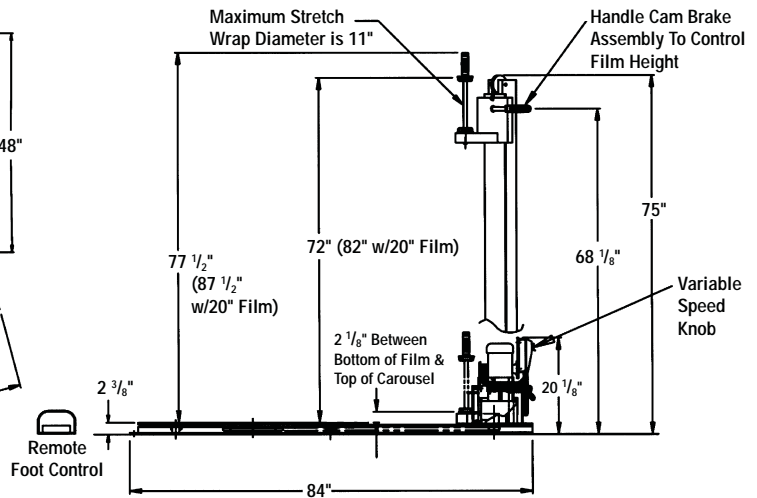

Stretch Wrap Machine

| MODEL NUMBER | CAROUSEL DIAMETER | CAROUSEL HEIGHT | CAPACITY (POUNDS) | # OF PALLETS WRAPPED PER HR. | MAX. LOAD DIAMETER | MAX. LOAD HEIGHT | R.P.M. | MOTOR HP |
|--------------|-------------------|-----------------|-------------------|------------------------------|--------------------|------------------|--------|----------|
| BSWA-48 | 48" | 2 3/8" | 4,000 | 4 TO 6 | 76" | 78" | 3-12 | 1/2 |
| BSWA-54 | 54" | 11" | 5,000 | 8 TO 12 | 86" | 75" | 3-12 | 1/2 |
| BSWA-60 | 60" | 11" | 5,000 | 8 TO 12 | 86" | 75" | 3-12 | 1/2 |

Approach Ramp Option

| MODEL NUMBER | WIDTH | LENGTH | HEIGHT |
|--------------|-------|--------|--------|
| BSWA-R-4836 | 48" | 36" | 2 1/8" |

* For use with model BSWA-48

Powered Mast Option

| MODEL NUMBER | MAX. LOAD HEIGHT | MIN. LOAD HEIGHT | MAX. FILM WEIGHT | MOTOR HP |
|--------------|------------------|------------------|------------------|----------|
| BSWA-PMO | 72" | 11" | 50 lbs. | 1/8 |

PUSH BUTTON HAND CONTROL - 110 V SINGLE PHASE

Extended Heights Available