

BPST SERIES Portable Lift Table

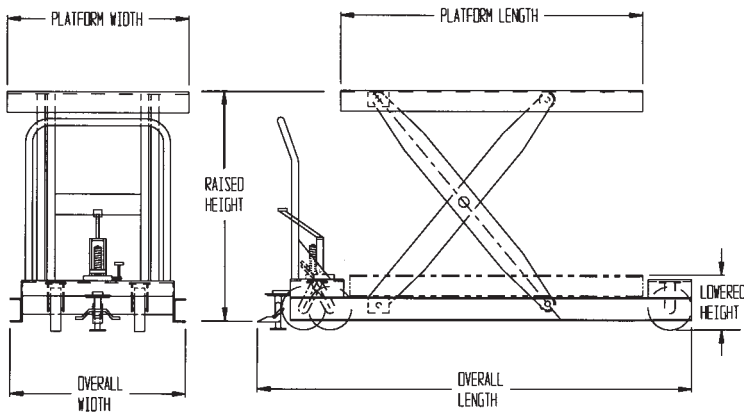

ENGINEERS SPECIFICATIONS

GENERAL

Portable Lift Table.

DESCRIPTION

The BPST Series increases productivity and decreases back fatigue and injuries. The unit has a service range of 10" lowered to 60" raised. 5,000 pounds capacity.

SCOPE

The portable scissor table can be utilized at more than one work station, load and unload trucks, transport materials and load heavy dies.

OPERATION

The standard BPST Series unit is operated with a manual single-speed foot pump. Optional AC, DC or AIR power units are available. A floor lock is included for securely anchoring the unit to the floor. A push handle is used for manually moving the unit.

CONSTRUCTION

All welded construction meeting AWS standard. Easily rolls on 8" phenolic casters. State of the art bushings for long life at all pivot points. Chrome plated pins.

HYDRAULICS

Hydraulic actuators are of the displacement style, installed rod-end down, and include an internal brass safety velocity fuse with stainless steel spring.

ELECTRICAL

A variety of power options are available for the BPST Series:
 The AC option includes a 110/208-230V / 1 phase or 208-230/460V / 3 phase / 60hz / 56 frame electric motor/pump combination. The standard control is a pendant hand control, 24V AC, NEMA 4 rating, on an 8' cord. An optional foot control is available. The DC option includes an electric motor/pump combination, a 12V deep cycle battery and a pendant hand control, 12V DC, NEMA 4 rating, on 8' cord. An optional foot control and battery charger is available.

The AIR option includes a compact reciprocating air motor/pump combination with a foot control. This option requires a minimum air flow rate of 12 cfm at an airline pressure of 80 psi.

SAFETY EQUIPMENT

Safety brass velocity fuse in cylinder protecting against sudden drop. Floor lock standard.

PAINT

Durable polyurethane blue enamel paint.

OWNERS MANUAL

An owners manual comes with each unit, including Serial Numbers, General Information, Wiring Schematics, Hydraulics Schematics, Operating Instructions, Loading and Unloading Instructions, Maintenance Instructions, Trouble Shooting Chart, Part Numbers Listed.

WARRANTY

Limited Warranty—1 year on structure, 1 year on hydraulic components and 1 year on electrical components.

PLATFORM WIDTH	PLATFORM LENGTH	CAPACITY	RAISED HEIGHT
24"-48"	48"-72"	1000 lbs.	46"
24"-48"	48"-72"	2000 lbs.	46"
24"-48"	48"-72"	3000 lbs.	46"
24"-48"	48"-72"	4000 lbs.	47"
36"-48"	48"-72"	5000 lbs.	47"
24"-48"	64"-90"	1000 lbs.	58"
24"-48"	64"-90"	2000 lbs.	58"
24"-48"	64"-90"	3000 lbs.	58"
36"-48"	64"-90"	4000 lbs.	60"
36"-48"	64"-90"	5000 lbs.	60"

MODEL NUMBER FORMAT: BPST [WIDTH × LENGTH] - [CAPACITY] - [RAISED HEIGHT]