

PALLET STACKER

SAFE ERGONOMIC ALTERNATIVE TO FORK TRUCKS AT A FRACTION OF THE COST

FEATURES

- Adjustable Fork Width Range From 8" to 37"
- Hand Held Pendant Control
- Standard Caster Lock
- Emergency Stop Velocity Fuse
- Handle Pallets, Skids, and Crates with or without an Understructure

OPTIONS

- DC, AC, or Air/Oil
- Bench Top or On-Board Battery Charger
- Battery Charge Indicator
- Portable Traction Drive System

MODEL: BPMPS-50



For Use with
Skids or Pallets

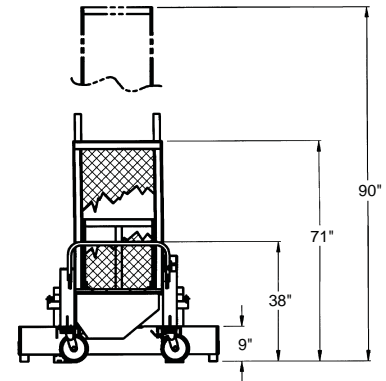

Drawings reflect BPM/BPS-50

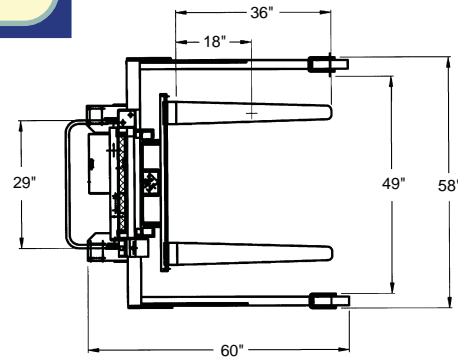

SPECIFICATIONS

Capacity	4,000 lbs.
Load Center	18"
Fork Size	4"W x 36"L x 1 1/2"H
Lowered Height	2"
Raised Fork Height (BPMPS-50)	50"
Raised Fork Height (BPMPS-60)	60"
Straddle Legs I.D.	49"
Straddle Legs O.D.	58"
Weight (BPMPS-50)	950 lbs.
Weight (BPMPS-60)	980 lbs.
Casters (Phenolic)	8" x 2" Swivel
Load Wheels (Phenolic)	8" x 2"
Battery	12V Deep Cycle



optional

PORTABLE TRACTION DRIVE SYSTEM

REDUCE BACK INJURY • REDUCE FATIGUE • EASY TO USE

MODEL: BPTDS (add as a suffix)

This factory installed option will reduce worker fatigue and injuries. An alternative to costly fork trucks, the BPTDS option makes portable equipment easy to maneuver. This state of the art operation allows a single operator to perform a task and safely transport the product.

FEATURES

- Programmable Motor Control
- Ergonomic, Adjustable Steering Yoke Control
- Autolocking Electromagnetic Brake
- Key Lockout
- Safety Horn
- 2 Deep Cycle Batteries
- Traction Drive Wheel
- Auto Reverse Emergency Switch
- 240 Degree Turning Radius