

# BED2 Series

## Post Office Edge of Dock Leveler

### MECHANICAL 20,000, 25,000 & 30,000 lb. CAPACITIES

**Beacon Industries, Inc.**  
 12300 Old Tesson Rd.  
 St. Louis, MO 63128-2247 USA  
 Phone: (314) 487-7600 Fax: (314) 487-0100  
[www.beacontechnology.com](http://www.beacontechnology.com)  
 E-Mail: [sales@beacontechnology.com](mailto:sales@beacontechnology.com)

#### ARCHITECTURAL SPECIFICATIONS

##### GENERAL

BED2 Series Post Office Edge of Dock Levelers are available in one hook lift style or one mechanical bar lift style:

**BED2 Series - Two movement mechanical Edge of Dock**

##### DESCRIPTION

Adjustable mechanical edge of dock leveler with two movements: (1) Up, (2) Down. Edge of Dock leveler to have a span of 27¾" with a deck width of \_\_\_\_\_ inches. Lip projection to extend horizontally \_\_\_\_\_ inches. Edge of Dock Leveler to meet or exceed the performance requirements of CS202-56., OSHA and ANSI MH14.1-1984.

##### SCOPE

These Edge of Dock levelers are designed to extend out toward the truck and can service vehicles with a height difference of 5" above the dock to 5" below the dock. Features include a 15" lip having a projection of 12¾" beyond the bumpers. On the standard 20,000 lb. model the stored position capacity is 30,000 lbs.

##### OPERATION

The operation is simple, lift the handle by pulling back the hook or the bar, then simply push forward to extend the unit into the vehicle. When vehicle departs, the edge of dock leveler will return automatically.



Hook activated model requires 80 lbs. of lifting force and the bar activated model requires 18 lbs. of lifting force.

##### CONSTRUCTION

The BED2 Series Post Office Edge of Dock Leveler is completely fabricated from structural steel components. Including 55,000 lb. minimum yield steel tread plate. Torsion spring lift assist, is easily adjusted with hand tools. Additionally included are two ⅝" formed plate steel bump blocks and molded cord rubber bumpers.

The edge of dock leveler is installed by others and is mounted externally to the dock face either by welding to embedded steel channel or welding and bolting directly to the dock face.

##### PAINT

Beacon Grey

##### OWNERS MANUAL

Owners Manual comes with each unit, including General Information, Installation and Anchoring Instructions, Operating Instructions, Maintenance Instructions, Parts List.

##### WARRANTY

The BED2 Series comes with a Limited Warranty - 2 years on structure and 1 year on parts.

HYDRAULIC MODELS	BHED266	BHED26617	BHED272	BHED266H	BHED272H
MECHANICAL MODELS	BED266M	BED266M17	BED272M	BED266MH	BED272MH
I. Lip Length	15"	17"	15"	15"	15"
II. Span	27-3/4"	29-3/4"	27-3/4"	27-3/4"	27-3/4"
C. Deck Width	66"	66"	72"	66"	72"
D. Overall Width	102"	102"	108"	102"	108"
E. Capacity (lbs.)	20M	20M	20M	25M	25M
F. Plate (Thick)	3/8"	3/8"	3/8"	7/16"	7/16"

#### ARCHITECTURAL SPECIFICATIONS

##### GENERAL

BHED2 Series Edge of Dock Levelers are available in one push button control hydraulic style:

**BED2 Series - Two movement hydraulic Edge of Dock**

##### DESCRIPTION

Adjustable hydraulic edge of dock leveler with two movements: (1) Up, (2) Down. Edge of Dock leveler to have a span of 27¾" with a deck width of \_\_\_\_\_ inches. Lip projection to extend horizontally \_\_\_\_\_ inches. Edge of Dock Leveler to meet or exceed the performance requirements of CS202-56., OSHA and ANSI MH14.1-1984.

##### SCOPE

These Edge of Dock levelers are designed to extend out toward the truck and can service vehicles with a height difference of 5" above the dock to 5" below the dock. Features include a 15" lip having a projection of 12¾" beyond the bumpers. On the standard 20,000 lb. model the stored position capacity is 30,000 lbs.

##### OPERATION

The operation is simple, a single push button control box operates the hydraulic edge of dock, when button is pushed the leveler goes up and extends out to truck bed, release button and lip will float down to

# BHED2 Series

## Post Office Edge of Dock Leveler

### HYDRAULIC 20,000, 25,000 & 30,000 lb. CAPACITIES

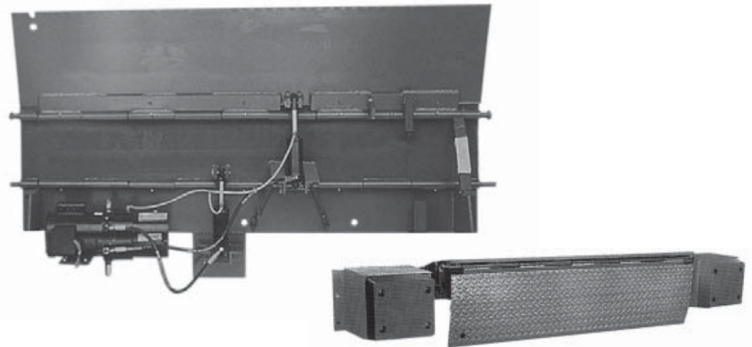

truck bed. When the vehicle departs, the edge of dock leveler will return automatically.

##### CONSTRUCTION

The BHED2 Series Edge of Dock is completely fabricated from structural steel components. Including 55,000 lb. minimum yield steel tread plate.

Additionally included are two ⅝" formed plate steel bump blocks and molded cord rubber bumpers.

The edge of dock leveler is installed by others and is mounted externally to the dock face either by welding to embedded steel channel or welding and bolting directly to the dock face.

##### ELECTRICAL & HYDRAULICS

Fully Automatic, Electric-Hydraulic, Two (2) cylinder

design, ½ HP Motor single phase, Push Button control operates the unit.

##### PAINT

Beacon Grey

##### OWNERS MANUAL

Owners Manual comes with each unit, including General Information, Installation and Anchoring Instructions, Wiring Schematics, Hydraulic Schematics, Operating Instructions, Maintenance Instructions, Parts List.

##### LEVELER WARRANTY

The BHED2 Series comes with a Limited Warranty - 2 years on structure and 2 years on parts.

# BED2-HL Series Post Office Edge of Dock Leveler

Hook Lift Style - 66" or 72" Submittal Drawing

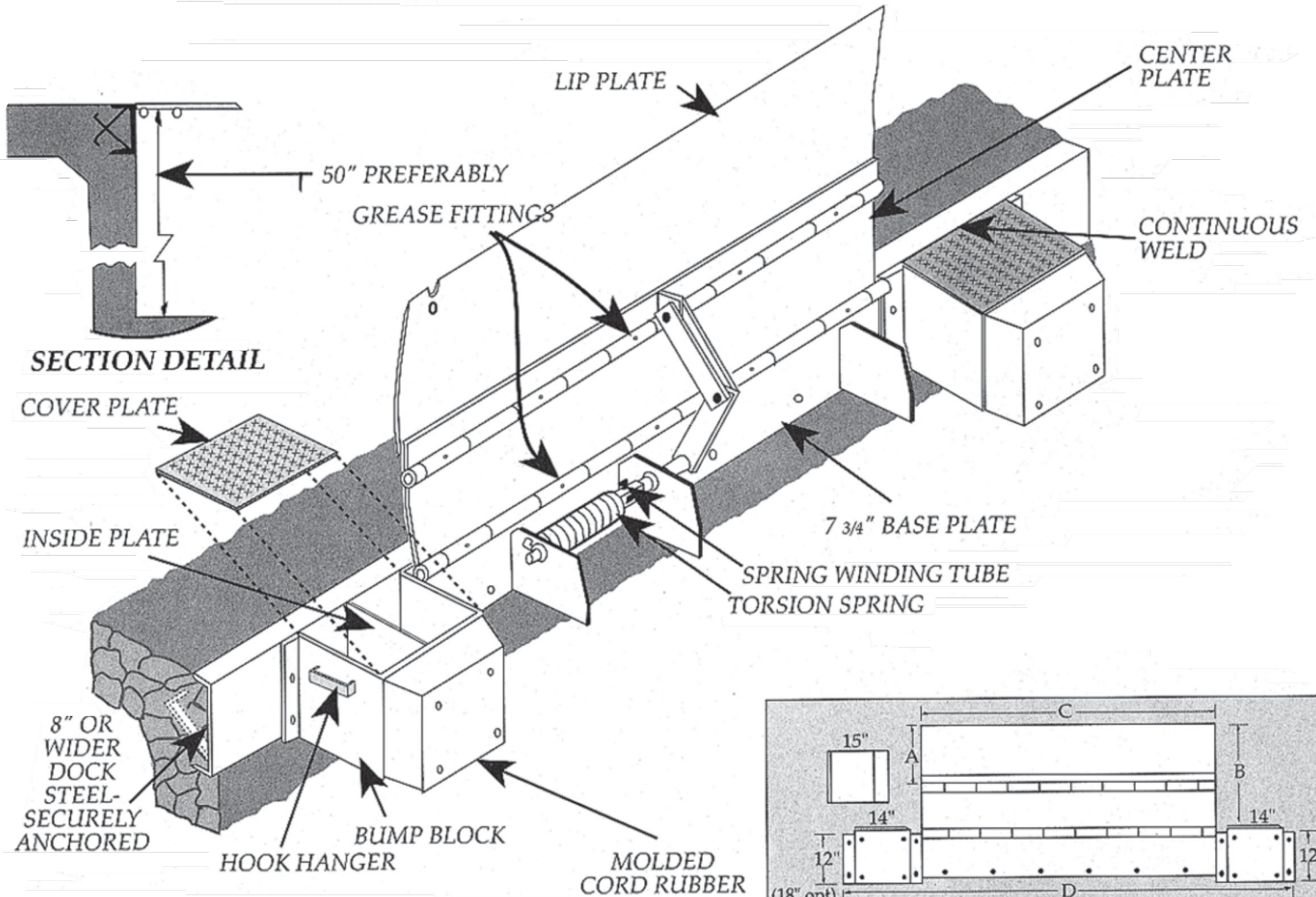

**NOTES:**

Deck & Lip - 55,000 lb. min. yield steel.  
**30,000 lb Capacity** Units include C1045 cold rolled 11/16" rod and cold drawn seamless tubing (1-1/4" OD, 5/16" wall).

Model	A	B	C	D	E	F
	Lip Length	Span	Deck Width	Overall Width	Rollover Capacity Lbs.	Plate Thickness
ED66M	15"	27 3/4"	66"	102"	20,000	3/8"
ED66M-17	17"	29 3/4"	66"	102"	20,000	3/8"
ED72M	15"	27 3/4"	72"	108"	20,000	3/8"
ED72 MH	15"	27 3/4"	72"	108"	25,000	7/16"
ED66 MH	15"	27 3/4"	66"	102"	25,000	7/16"

**SPECIFY JOB REQUIREMENTS FROM CHART**

--	--	--	--	--	--	--

**JOB**

# BED2-BL Series

## Post Office Edge of Dock Leveler

### Bar Easy Lift Style - 66" or 72" Submittal Drawing

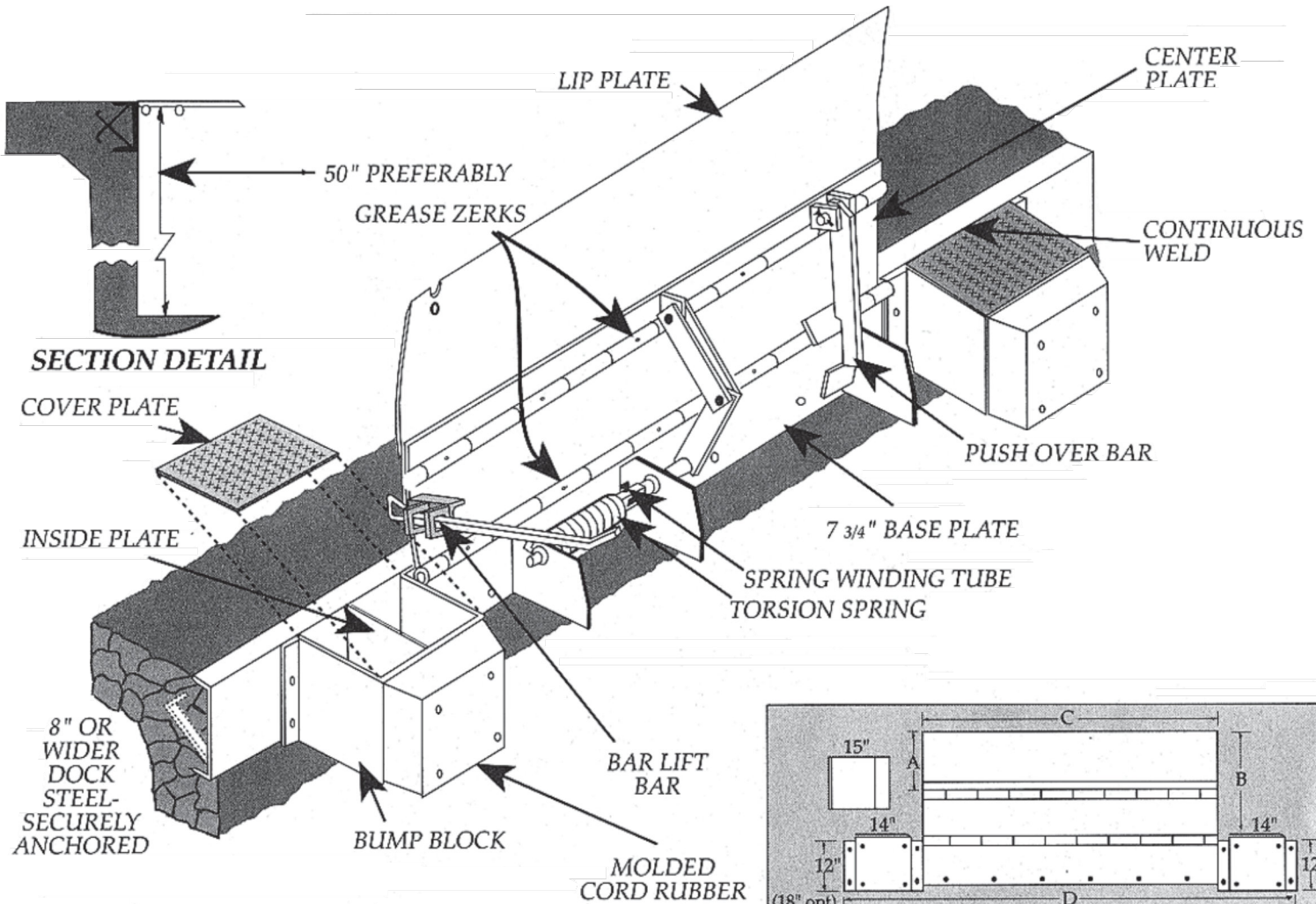

**NOTES:**

Deck & Lip - 55,000 lb. min. yield steel.  
 30,000 lb Capacity Units include C1045 cold rolled 11/16" rod and cold drawn seamless tubing (1-1/4" OD, 5/16" wall).

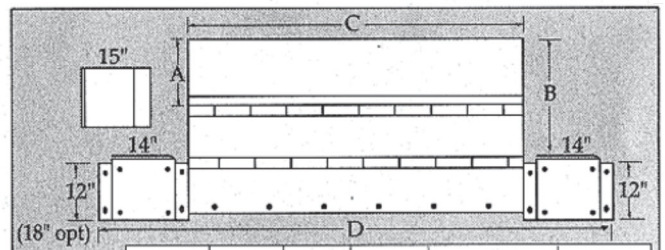

Model	A Lip Length	B Span	C Deck Width	D Overall Width	E Rollover Capacity Lbs.	F Plate Thickness
BL66	15"	27 3/4"	66"	102"	20,000	3/8"
BL66-17	17"	29 3/4"	66"	102"	20,000	3/8"
BL72	15"	27 3/4"	72"	108"	20,000	3/8"
BL72 H	15"	27 3/4"	72"	108"	25,000	7/16"
BL66 H	15"	27 3/4"	66"	102"	25,000	7/16"

**SPECIFY JOB REQUIREMENTS FROM CHART**

--	--	--	--	--	--	--

**JOB**

# BHED2 Series

## Post Office Edge of Dock Leveler

66" or 72" Submittal Drawing

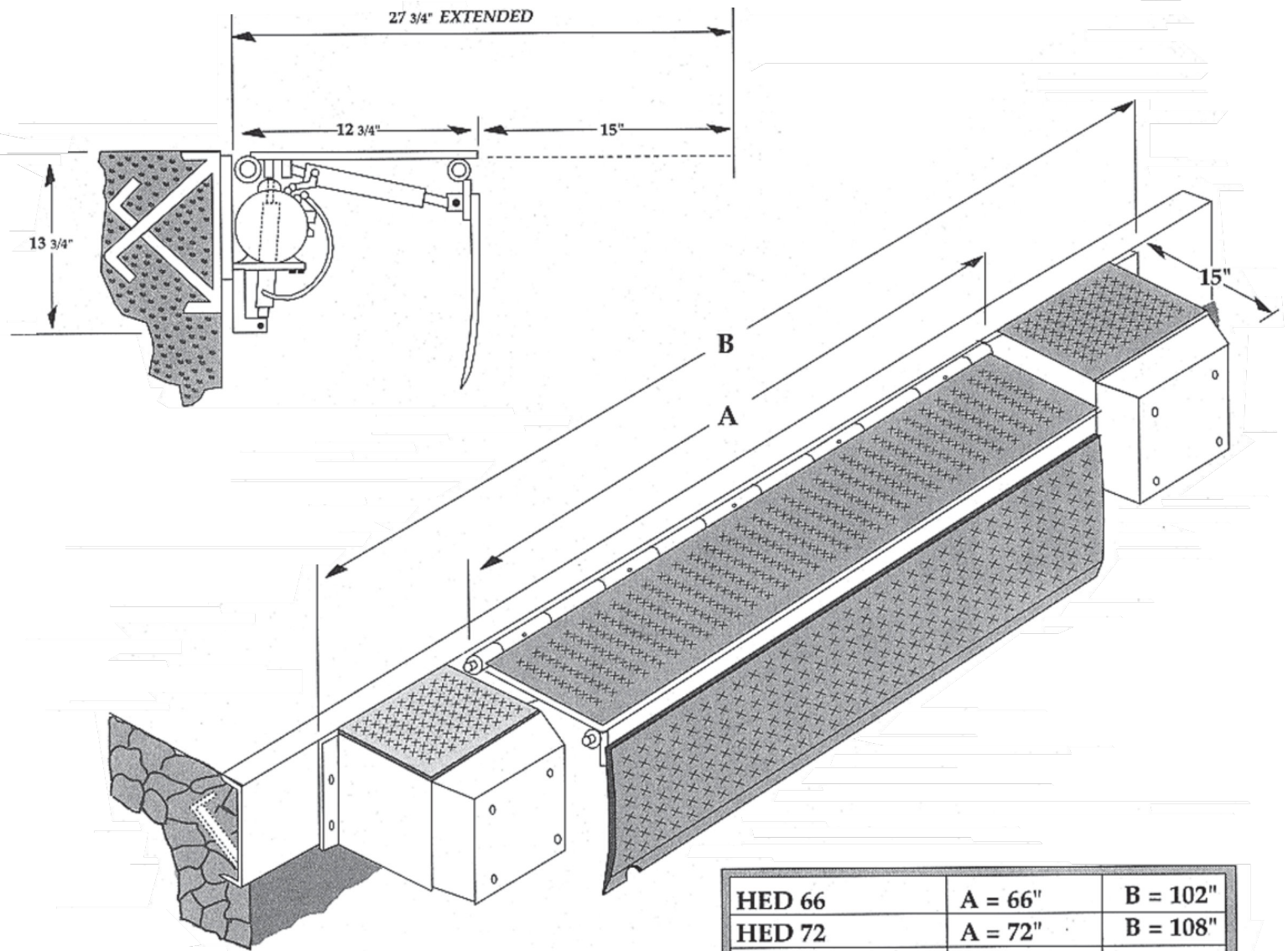

HED 66	A = 66"	B = 102"
HED 72	A = 72"	B = 108"
1/2 Hp. 1 ph. Std.)	(3 ph. Opt.)	

**JOB**