

Double Decker Hardwood Platform Cart

Model
BVHPT/D

- LIGHTWEIGHT
- DURABLE
- ECONOMICAL



Minimize lifting and bending with this new cart/portable work bench, the **Wood Platform Cart**. Ideal for shipping areas, offices, and plant use, these economical carts are perfect for many of your applications. Constructed of 1" thick hardwood platform and steel push handle, the **BVHPT/D** has a maximum capacity of 800 lbs. per shelf. Casters are (4) 6" x 2" mold-on-rubber. Countersunk holes allow for a smooth deck surface. Optional adjustable height top shelf available.

MODEL NUMBER	DECK SIZE (W x L)	CAPACITY	TOP SHELF HEIGHT	BOTTOM SHELF HT.
BVHPT/D-2448	24" x 48"	1,600 lbs.	30-1/8"	9-1/2"
BVHPT/D-2754	27" x 54"	1,600 lbs.	30-1/8"	9-1/2"
BVHPT/D-3060	30" x 60"	1,600 lbs.	30-1/8"	9-1/2"
BVHPT/D-3672	36" x 72"	1,600 lbs.	30-1/8"	9-1/2"

Assembly required

Steel Cantilever STOCKPICKER TRUCK

- Warehouses
- Stockrooms
- Offices
- Industrial/Commercial



AUTOMATIC SELF LOCKING LADDER



Moving extra large packages is no longer a problem with the all steel constructed **Steel Cantilever Stockpicker Truck**, model **BSPS2-2041-C**. This durable stockpicker truck eliminates the need to move around a clumsy ladder and push cart while trying to stock or unstock shelves. The unique cantilever design allows for oversized packages to fit conveniently on the bottom shelf, without restricting access to the package. The step ladder is spring loaded allowing the cart to hold securely in place while a person is standing on the ladder; as the weight is removed the ladder elevates to allow full mobility. Standard casters are 4" x 2" mold-on-rubber. Total capacity is 440 lbs. Top shelf capacity is 110 lbs. Bottom shelf capacity is 330 lbs.

DIMENSIONS

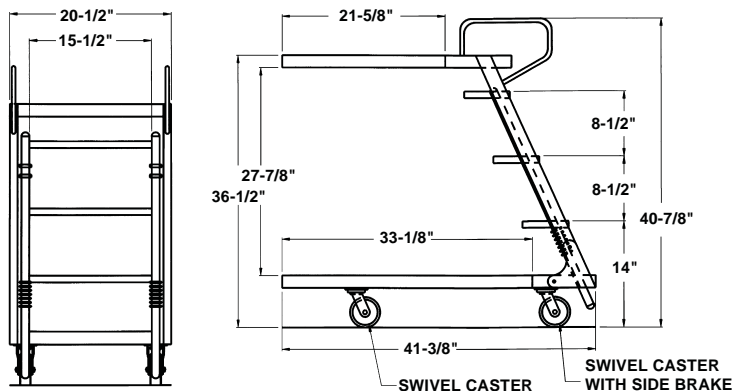

ATTACHES TO MANY
CARTS & TABLES

Bench Top Tilters



Ergo-Handle
Carts



Hydraulic Post Tables



Heavy-duty steel **Bench Top Tilters** handle loads up to 1,000 pounds and may be tilted from 0° to 45°. Easily attached to most industrial table tops, work benches and mobile lift tables of sufficient load capacity and surface size. Unit slides back as it tilts to maintain the center of gravity over the frame.

Electro-Mechanical design is equipped with a pendant hand control, with up and down push buttons located on an 8 foot cord, maximizing operator convenience. Flat base plate with slotted holes for installation.

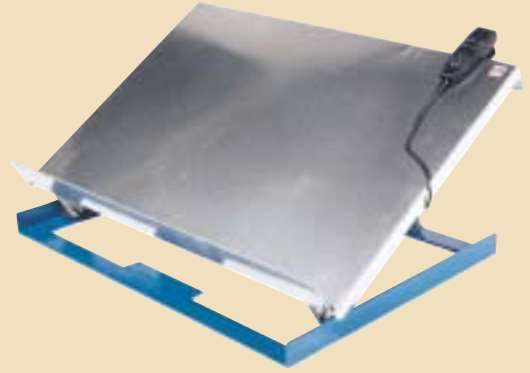

Model Number	Operation	Platform Size (W x L x H)	Capacity (Pounds)	Weight (Pounds)
BBTT-6-36	Manual	28" x 36" x 2"	600	50
BBTT-6-46	Manual	28" x 46" x 2"	600	60
BBTT-5-36	Electro-Mechanical	28" x 36" x 5"	500	70
BBTT-5-46	Electro-Mechanical	28" x 46" x 5"	500	80
BBTT-10-36	Electro-Mechanical	28" x 36" x 3"	1000	80
BBTT-10-46	Electro-Mechanical	28" x 46" x 3"	1000	90

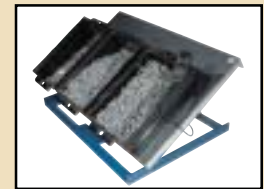

STAINLESS STEEL - SHELVING & CARTS

SIMPLE ASSEMBLY

SOLID SHELVES

304 STAINLESS STEEL

DURABLE CONSTRUCTION



Ideal for food, chemical and pharmaceutical applications, these shelves and carts work well to provide spacious, efficient storage or to transport from one workstation to another. Both units have raised edges on each shelf to cut down on contamination by containing spills while providing easy clean up. The Stainless Steel Cart has 5" mold-on-rubber casters (2 swivel and 2 rigid).

STAINLESS STEEL SHELVING

Model Number	Number of Shelves	Overall Size (W x D x H)	Shelf Capacity
BSSS-1836	4	36" x 18" x 74"	600 lbs.
BSSS-1848	4	48" x 18" x 74"	600 lbs.
BSSS-2436	4	36" x 24" x 74"	600 lbs.
BSSS-2448	4	48" x 24" x 74"	600 lbs.

STAINLESS STEEL CART

Model Number	Number of Shelves	Overall Size (W x D x H)	Shelf Capacity	Total Capacity
BSSC-1836	3	36" x 18" x 40"	250 lbs.	750 lbs.
BSSC-1848	3	48" x 18" x 40"	250 lbs.	750 lbs.
BSSC-2436	3	36" x 24" x 40"	250 lbs.	750 lbs.
BSSC-2448	3	48" x 24" x 40"	250 lbs.	750 lbs.

Beacon Industries, Inc.

12300 Old Tesson Rd.
St. Louis, MO 63128-2247 USA
Phone: (314) 487-7600 Fax: (314) 487-0100
www.beacontechnology.com
E-Mail: sales@beacontechnology.com