

# Mechanical Edge of Dock Leveler BBLE Submittal Drawing

06/19

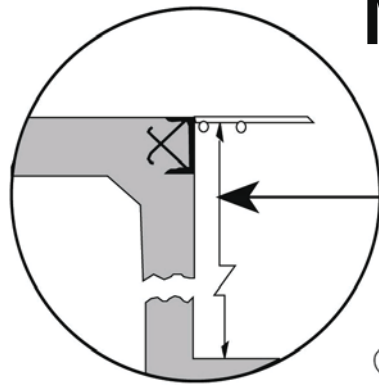

SECTION DETAIL

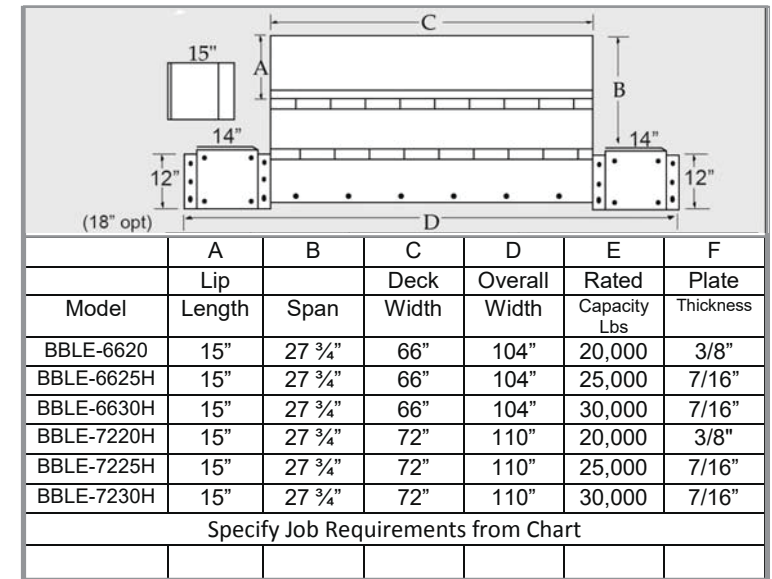
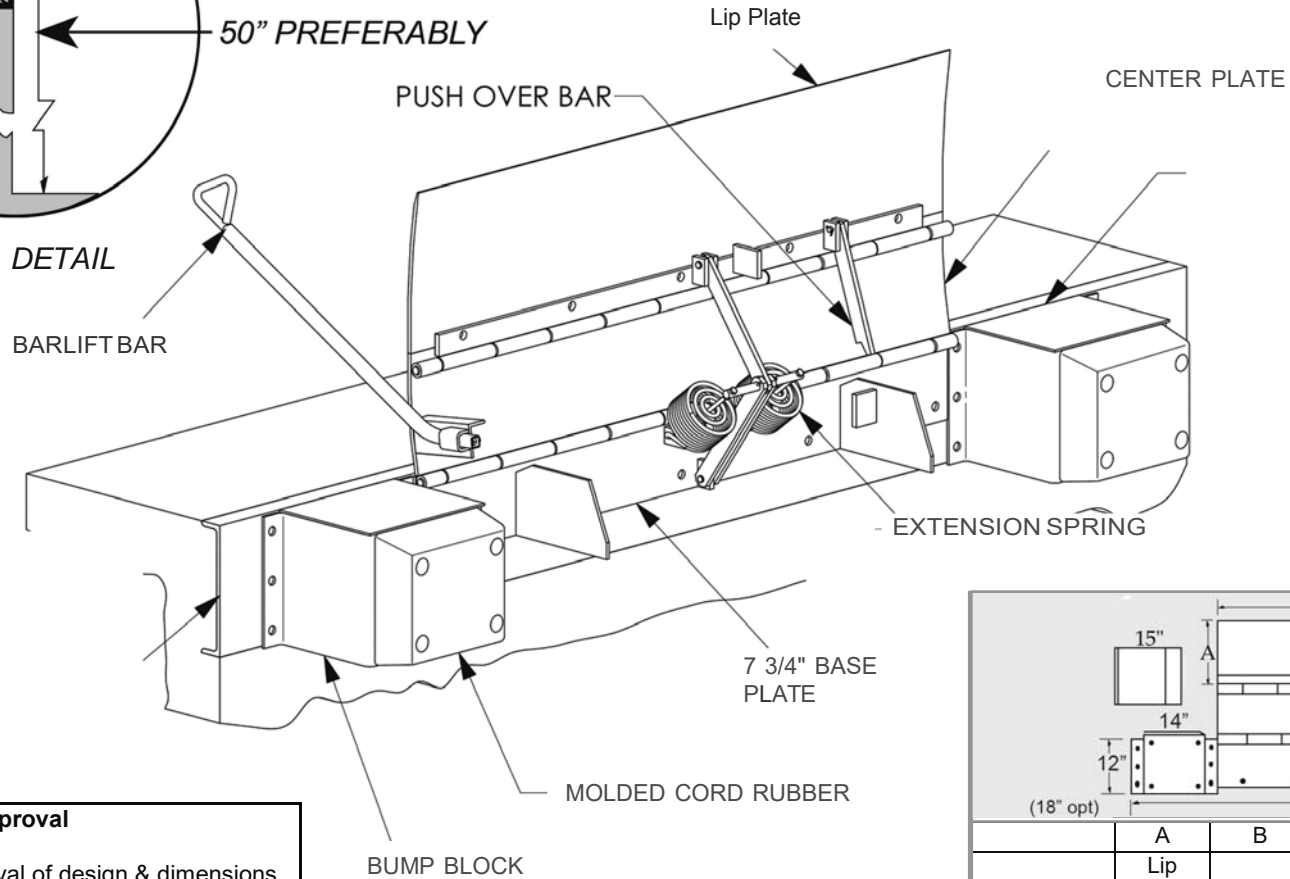

Notes: Deck & Lip - 55,000 min. yield steel

**Approval**

This includes my approval of design & dimensions.

Signed: \_\_\_\_\_

Date: \_\_\_\_\_



**BEACON INDUSTRIES, INC.**

12300 Old Tesson Rd.

St. Louis, MO 63128-2247 USA

OFFICE: 314-487-7600 FAX: 314-487-0100

Customer:

Project:

Quote: