

# MOBILE BOX STACKER

The Adjustable Box Stacker is specially designed for transporting, stacking, and lifting plastic containers. All models are compact and light weight. Both fork width and box clamps are adjustable to fit different size plastic containers. All box clamps are rubber coated to protect your plastic container.

## MODEL: BABS-115

STANDARD

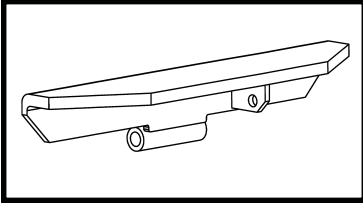

L-TYPE

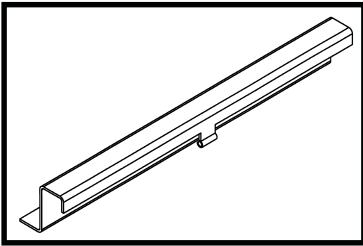

T-TYPE

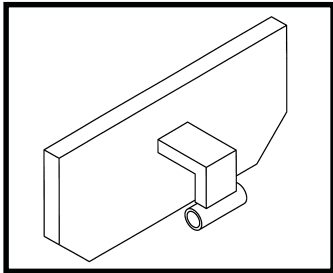

DRIVING HANDLE

PUMP PEDAL

STEERING WHEEL

SIDE CLAMP

CATCH FORK

STAND FORK

LOAD WHEEL

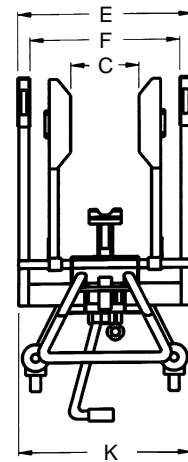
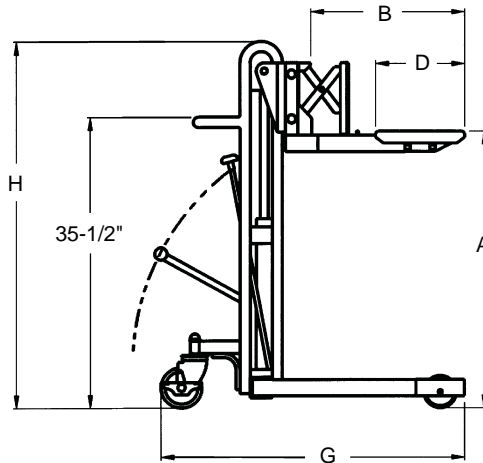
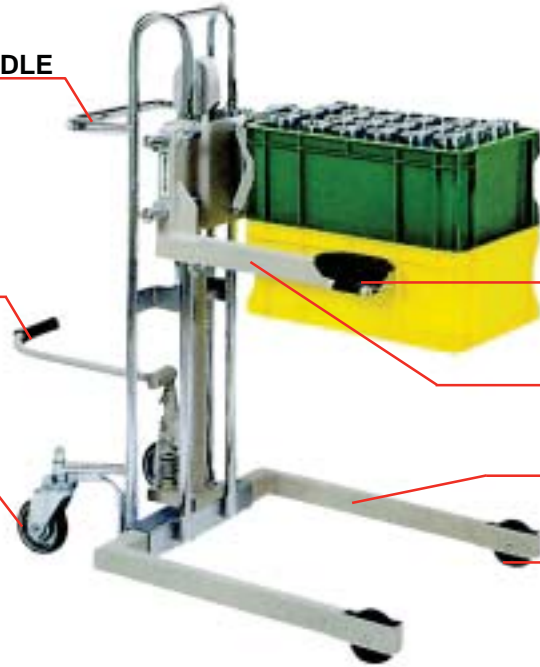

Load Wheels: 4" x 1" (Mold-on-Rubber)  
Casters: 5" x 1 5/8" (Mold-on-Rubber)

MODEL	Capacity (lb.)	Lowered Height (in.)	Raised Height (in.)	Fork Size (in.)		Box clamp (in.)	Outrigger (in.)		Overall (in.)			Number of Foot Pumps	Weight (lb.)
			A	Length	Width		O.D.	I.D.	L	W	H		
				B	C		D	E	F	G	K		
BABS-115	330	2 3/4	33 1/2	19 2/3	8 to 15 3/4	11	17 3/4 to 23 2/3	14 to 20	37 1/2	21	44 2/3	18	112
BABS-130			47 1/4								58 1/2		
BABS-115L	330	Floor	31	25 1/2	10 to 17 3/4	22 1/2	17 3/4 to 23 2/3	14 to 20	41 1/4	21	44 2/3	18	110
BABS-130L			44 3/4								58 1/2		
BABS-115T	330	3 1/2	34 1/4	20	9 1/2 to 17 1/4	7 3/4	17 3/4 to 23 2/3	14 to 20	37 1/2	21	44 2/3	18	110
BABS-130T			48								58 1/2		