

# HIGH LIFT PALLET JACK - BTAL-200-DC

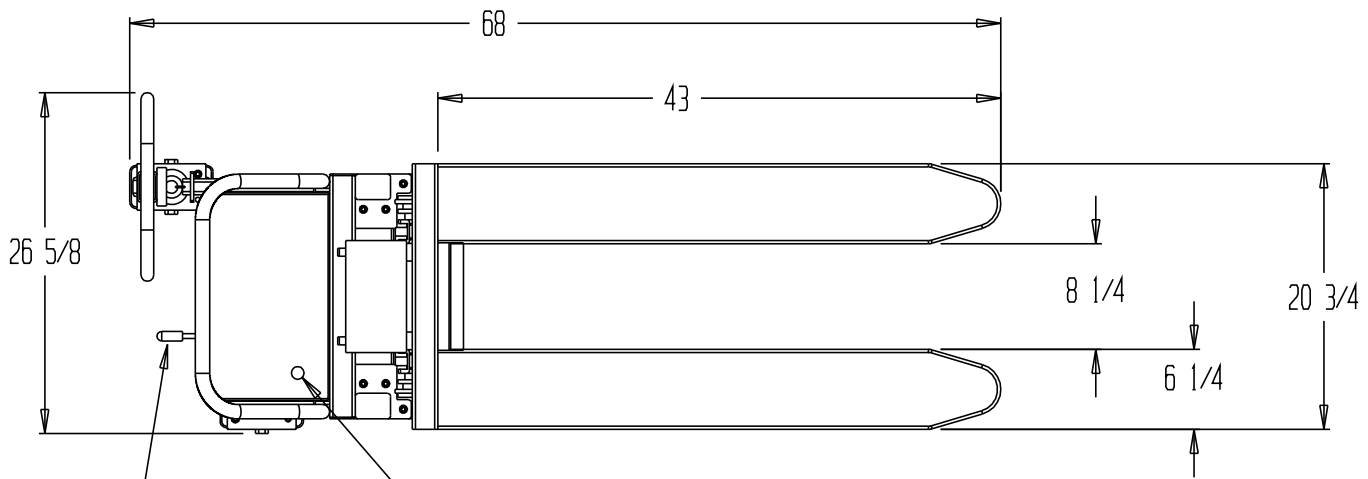

RAISE/LOWER  
HANDLE

EMERGENCY  
STOP

**PLEASE CIRCLE SPECIFICATIONS:**

POWER	<input type="checkbox"/> AC	<input checked="" type="checkbox"/> DC (12V)	<input type="checkbox"/> AIR/OIL	
MOTOR VOLTAGE	<input type="checkbox"/> 115	<input type="checkbox"/> 208	<input type="checkbox"/> 230	<input type="checkbox"/> 460
DEDICATED CIRCUIT REQUIRED				
MOTOR PHASE	<input type="checkbox"/> SINGLE		<input type="checkbox"/> THREE	
CONTROL	<input checked="" type="checkbox"/> HAND		<input type="checkbox"/> *FOOT	
* BATTERY CHRG.	<input type="checkbox"/> REMOTE		<input type="checkbox"/> ON-BOARD	
* CHRG. INDICATOR	<input checked="" type="checkbox"/> YES		<input type="checkbox"/> NO	

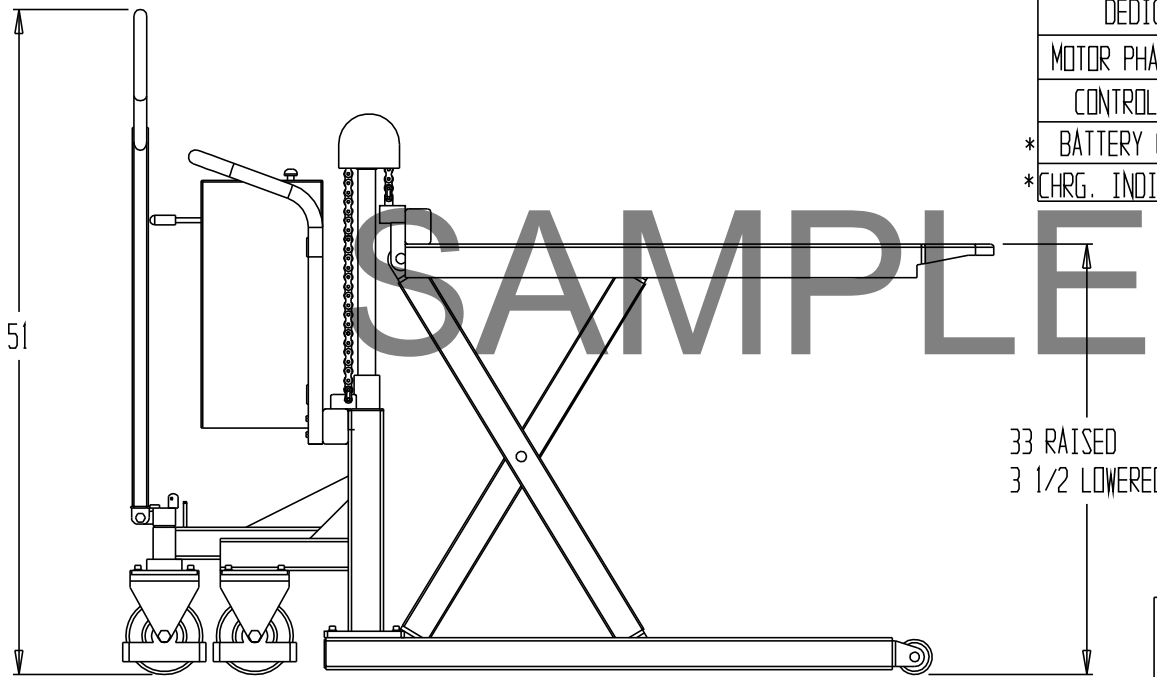

33 RAISED  
3 1/2 LOWERED

PRODUCTION WILL START UPON  
RECEIPT OF SIGNED APPROVAL  
DRAWING

## STANDARD FEATURES

MODEL NUMBER: BTAL-220-DC  
CAPACITY: 2,200 LBS.  
OVERALL WIDTH: 26 5/8"  
OVERALL LENGTH: 68"  
OVERALL HEIGHT: 51"  
RAISED FORK HEIGHT: 33"  
LOWERED FORK HEIGHT: 3 1/2"  
USABLE FORK LENGTH: 43"  
OVERALL FORK WIDTH: 20 3/4"  
INDIVIDUAL FORK WIDTH: 6 1/4"  
STANDARD 12 V DC POWERED

## SPECIAL FEATURES

NONE

## APPROVAL

I, the undersigned, hereby approve this print  
[ ] As drawn [ ] As marked  
This includes my approval of design & dimensions.  
Signed: \_\_\_\_\_  
Date: \_\_\_\_\_

\*\*SPECIAL UNITS ARE NON-RETURNABLE  
\*AVAILABLE AT ADDITIONAL COSTS

BEACON INDUSTRIES, INC.		P.O.#: -
DRAWN BY: SR		W.O.#: -
DATE: 6-4-04	SALES: -	
REFERENCE:	DRWG./FILE NAME:	
-	scale: 1:15	TAL-220-DC