

PORTABLE LIFT TABLE - BPST SERIES

APPROX WEIGHT:
DOES NOT INCLUDE WEIGHT OF POWER OR PACKAGING!!!

ANY ADDITIONS, DELETIONS, OR OMISSIONS MUST BE CORRECTED ON THIS DRAWING AS THIS DRAWING WILL BE CONSIDERED ALL INCLUSIVE
ALL GRAPHICS PROVIDED ARE FOR REFERENCE ONLY. IF CERTAIN DIMENSIONS ARE CRITICAL PLEASE VERIFY THOSE DIMENSIONS WITH YOUR SALESPERSON

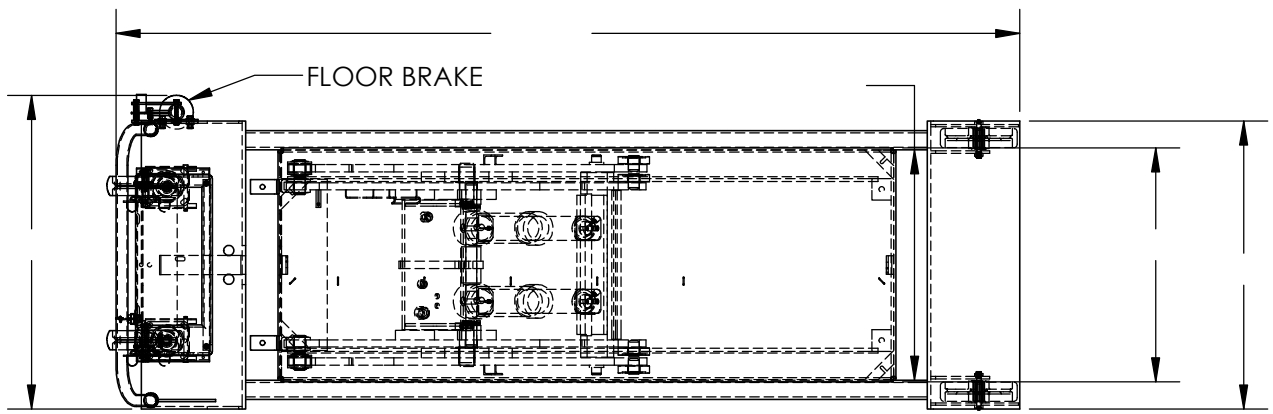

STANDARD:
12 V DC HYDRAULIC POWER UNIT
RAISED & LOWER BUTTONS ARE IN
TOP OF POWER UNIT
WITH ON BOARD CHARGER

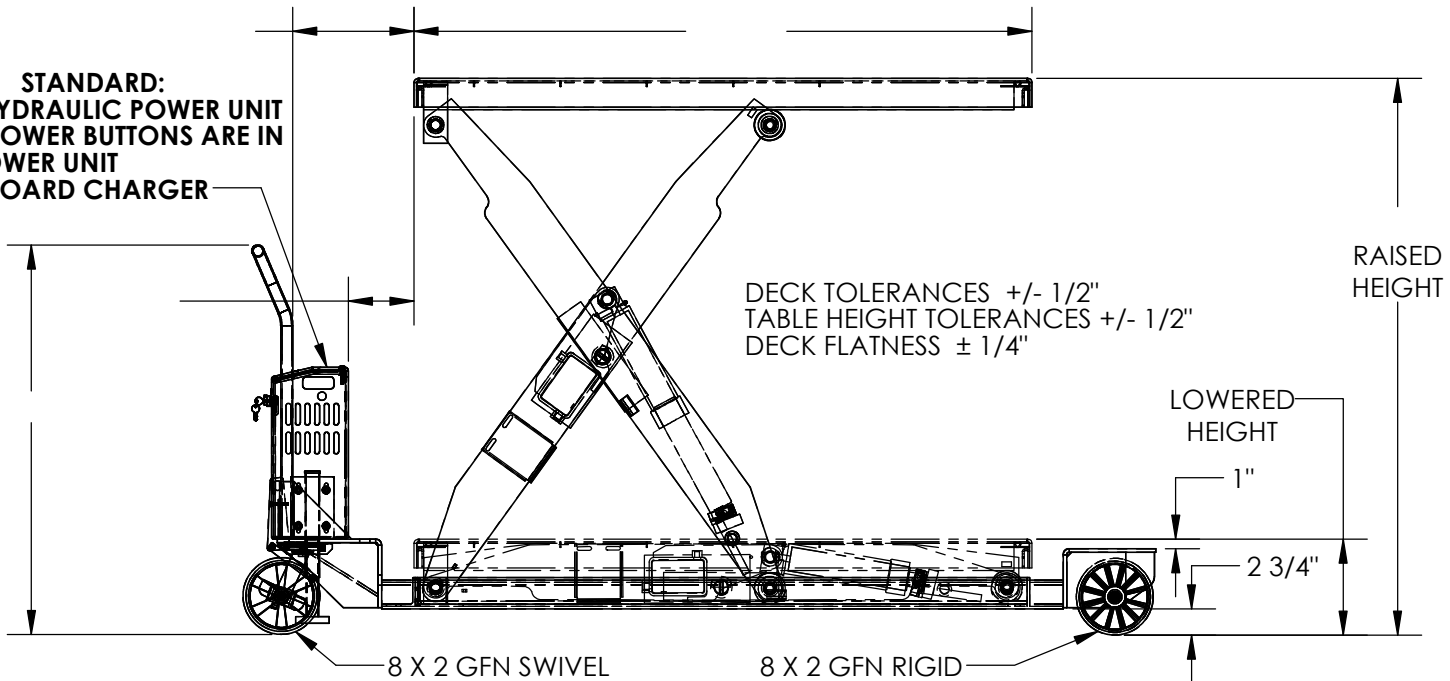

FOR INTERNAL USE ONLY PROJECT SIGN OFF	
SALES	
ENG.	
FAB.	
POWER	

STANDARD FEATURES

- MODEL NUMBER: BPST SERIES
- CAPACITY:
- PLATFORM WIDTH:
- PLATFORM LENGTH:
- PLATFORM LOWERED HEIGHT:
- PLATFORM RAISED HEIGHT:
- OVERALL WIDTH:
- OVERALL LENGTH:
- GROUND CLEARANCE:
- CASTERS: TWO 8 X 2 GFN SWIVEL
TWO 8 X 2 GFN RIGID

STANDARD ELECTRICAL SPECIFICATIONS

12 VOLT DC WITH ON-BOARD CHARGER

SPECIAL FEATURES

NONE

APPROVAL

I, THE UNDERSIGNED, AGREE THAT THE PRODUCT AS REPRESENTED SATISFIES DESIGN AND DIMENSION REQUIREMENTS. I ALSO ACKNOWLEDGE MY DUTY TO CONFIRM PRODUCT AND INSTALLATION COMPLIANCE WITH ALL APPLICABLE FEDERAL, STATE AND LOCAL REGULATIONS AND STANDARDS.
ALL SPECIAL UNITS ARE NON-RETURNABLE
[] As drawn [] As marked

Signed: _____ Date: _____

LEAD TIME WILL START UPON RECEIPT OF SIGNED APPROVAL DRAWING

BEACON INDUSTRIES, INC.

DRAWN BY: DLS

DATE: 9/26/2014

REFERENCE:

SCALE: 1:20

QUOTED LEAD TIME:

QUOTE #

P.O.#

W.O.#

SALES:

FILE NAME:

01-007-089