

POWERED CAROUSAL - BPOW-CAR-50

APPROX WEIGHT: 439.21 lbs.
 DOES NOT INCLUDE WEIGHT OF POWER OR PACKAGING!!!

*** ANY ADDITIONS, DELETIONS, OR OMISSIONS MUST BE CORRECTED ON THIS DRAWING AS THIS DRAWING WILL BE CONSIDERED ALL INCLUSIVE ***

ALL GRAPHICS PROVIDED ARE FOR REFERENCE ONLY. IF CERTAIN DIMENSIONS ARE CRITICAL PLEASE VERIFY THOSE DIMENSIONS WITH YOUR SALESPERSON

FOR INTERNAL USE ONLY
 PROJECT SIGN OFF

SALES	
ENG.	
FAB.	
POWER	

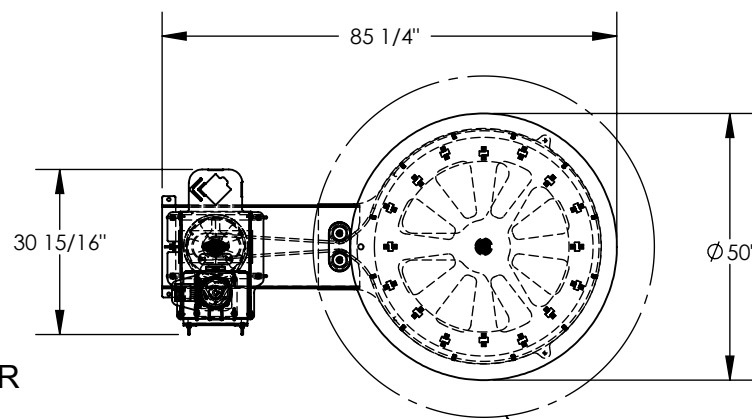

MAX. LOAD CLEARANCE
 DIAMETER 64" INCLUDES
 FILM ROLL DIAMETER

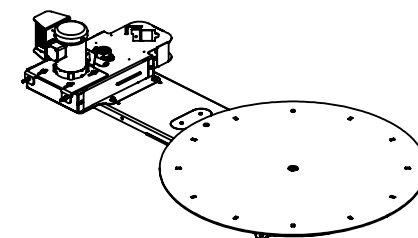

3-D VIEW FOR REFERENCE

COLOR SPECIFICATIONS

DECK IS TOUGH BAKED IN POWDER
 COATED YELLOW FINISH

FRAME IS TOUGH BAKED IN
 POWDER COATED BLUE FINISH

**THE USE OF A GFCI WILL REQUIRE THE USE OF A LINE-REACTOR
 CONSULT YOUR LOCAL ELECTRICAL SUPPLIER FOR DETAILS**



DIMENSION TOLERANCE ± 1/4"

STANDARD FEATURES MODEL

NUMBER IS BPOW-CAR-50

CAPACITY IS 4000 LBS.

TURN TABLE DIAMETER IS $\phi 50"$
 OVERALL LENGTH IS 85 1/4"
 OVERALL HEIGHT IS 15 3/8"
 TURN TABLE DECK HEIGHT IS 2 1/16"
 POWER INPUT IS 115 V 1-PHASE
 BELT DRIVEN
 VARIABLE SPEED TURN TABLE
 (3-12 RPM)
 WITH SOFT START/STOP
 FOOT CONTROL FOR
 TURN TABLE ROTATION

POWER SPECIFICATIONS

AC POWER
 MOTOR VOLTAGE: 115V
 MOTOR PHASE: SINGLE
 CONTROL: FOOT

SPECIAL FEATURES

NONE

APPROVAL

I, THE UNDERSIGNED, AGREE THAT THE PRODUCT AS
 REPRESENTED SATISFIES DESIGN AND DIMENSION
 REQUIREMENTS. I ALSO ACKNOWLEDGE MY DUTY TO
 CONFIRM PRODUCT AND INSTALLATION
 COMPLIANCE WITH ALL APPLICABLE FEDERAL, STATE
 AND LOCAL REGULATIONS AND STANDARDS.
ANY MODIFIED UNITS ARE NON-RETURNABLE

[] As drawn [] As marked

Signed: _____ Date: _____

Printed Name: _____

LEAD TIME WILL START UPON RECEIPT OF SIGNED APPROVAL DRAWING

Beacon Industries, Inc.		P.O.# X
		W.O.# X
DRAWN BY: SJA	DATE: 12/02/2014	SALES: X
REFERENCE: X	SCALE: 1:36	FILE NAME:
QUOTED LEAD TIME: X	QUOTE # X	20-007-150