

HYDRAULIC BOX DUMPERS - BHBD SERIES

APPROX WEIGHT:
DOES NOT INCLUDE WEIGHT OF POWER OR PACKAGING!!!

*** ANY ADDITIONS, DELETIONS, OR OMISSIONS MUST BE CORRECTED ON THIS DRAWING AS THIS DRAWING WILL BE CONSIDERED ALL INCLUSIVE ***

ALL GRAPHICS PROVIDED ARE FOR REFERENCE ONLY. IF CERTAIN DIMENSIONS ARE CRITICAL PLEASE VERIFY THOSE DIMENSIONS WITH YOUR SALESPERSON

FOR INTERNAL USE ONLY
PROJECT SIGN OFF

SALES	
ENG.	
FAB.	
POWER	

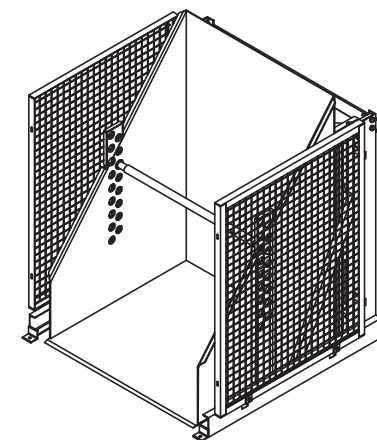
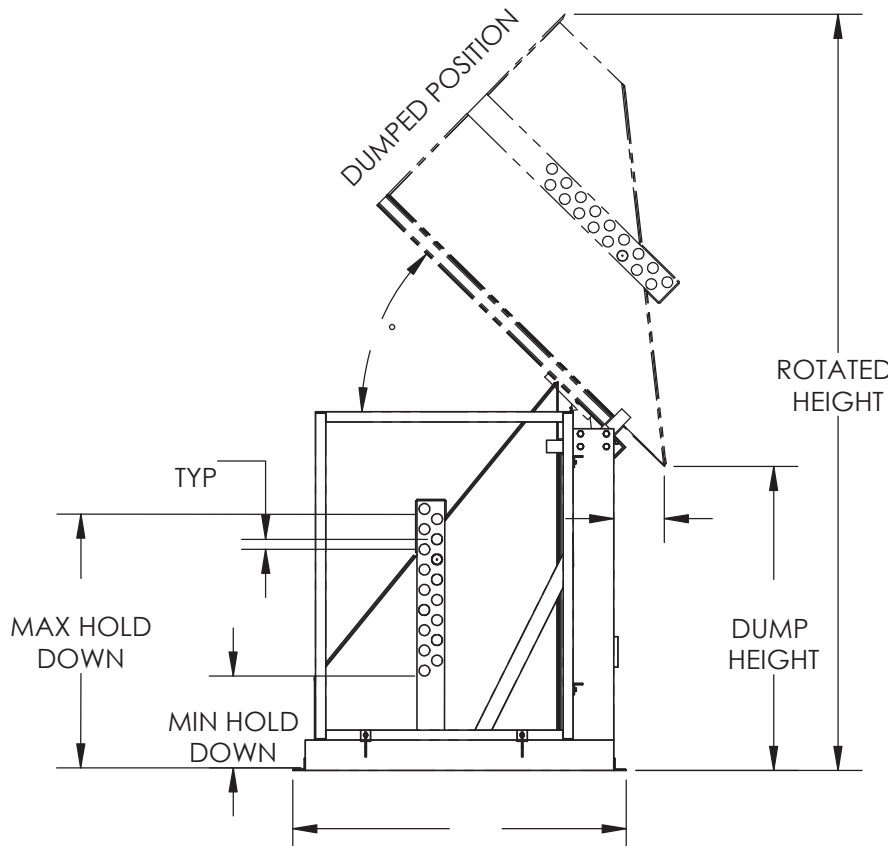
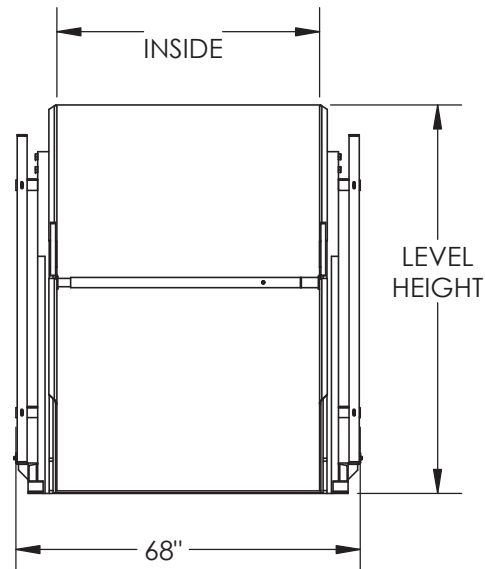

DIMENSION TOLERANCE ± 1/4"

STANDARD FEATURES

HYDRAULIC BOX DUMPERS
MODEL NUMBER IS BHBD SERIES
CHUTE IS 52" W X 50" L (USABLE)
DUMPER CAPACITY IS DUMP
HEIGHT IS
HOLD DOWN WILL ACCEPT BOXES
--" TO --" HIGH W/ HOLES EVERY 2"
FRAME WIDTH IS
FRAME LENGTH IS
LEVEL HEIGHT IS
ROTATED HEIGHT IS
DUMP ANGLE IS
CHROME PLATED CYLINDER WITH
EMERGENCY STOP VELOCITY FUSE
PAINT IS ROYAL BULE
WARNING: CHECK STATE AND LOCAL CODES!!
WARRANTY PER FORM WTY-EH4

PLEASE CIRCLE SPECIFICATIONS:

POWER	<input checked="" type="checkbox"/> AC	<input type="checkbox"/> * DC	<input type="checkbox"/> * AIR/OIL
MOTOR VOLTAGE	<input type="checkbox"/> 115	<input type="checkbox"/> 208	<input checked="" type="checkbox"/> 230 <input checked="" type="checkbox"/> 460
DEDICATED CIRCUIT REQUIRED			
MOTOR PHASE	<input type="checkbox"/> SINGLE	<input checked="" type="checkbox"/> THREE	
CONTROL	<input checked="" type="checkbox"/> HAND	<input type="checkbox"/> * FOOT	
~ ALL BATTERY CHARGERS ARE 115V AC ~			
* BATTERY CHRG.	<input type="checkbox"/> REMOTE	<input type="checkbox"/> ON-BOARD	
* CHRG. INDICATOR	<input type="checkbox"/> YES	<input type="checkbox"/> NO	

* AVAILABLE AT ADDITIONAL COST

SPECIAL FEATURES
NONE

APPROVAL

I, THE UNDERSIGNED, AGREE THAT THE PRODUCT AS REPRESENTED SATISFIES DESIGN AND DIMENSION REQUIREMENTS. I ALSO ACKNOWLEDGE MY DUTY TO CONFIRM PRODUCT AND INSTALLATION COMPLIANCE WITH ALL APPLICABLE FEDERAL, STATE AND LOCAL REGULATIONS AND STANDARDS.
ALL SPECIAL UNITS ARE NON-RETURNABLE
[] As drawn [] As marked

Signed: _____ Date: _____

LEAD TIME WILL START UPON RECEIPT OF SIGNED APPROVAL DRAWING

BEACON INDUSTRIES, INC.		P.O.
		W.O.#
DRAWN BY: SJA	DATE: 2/4/2015	SALES:
REFERENCE:	SCALE: 1:38	FILE NAME:
QUOTED LEAD TIME:	QUOTE #	34-007-038