

# LIFT TABLE - BEHLT-72120-5-82

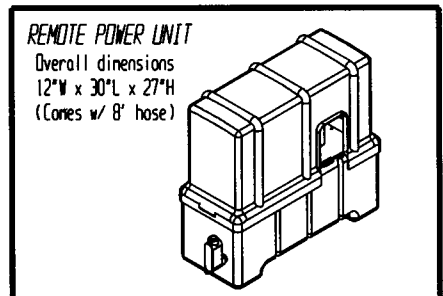
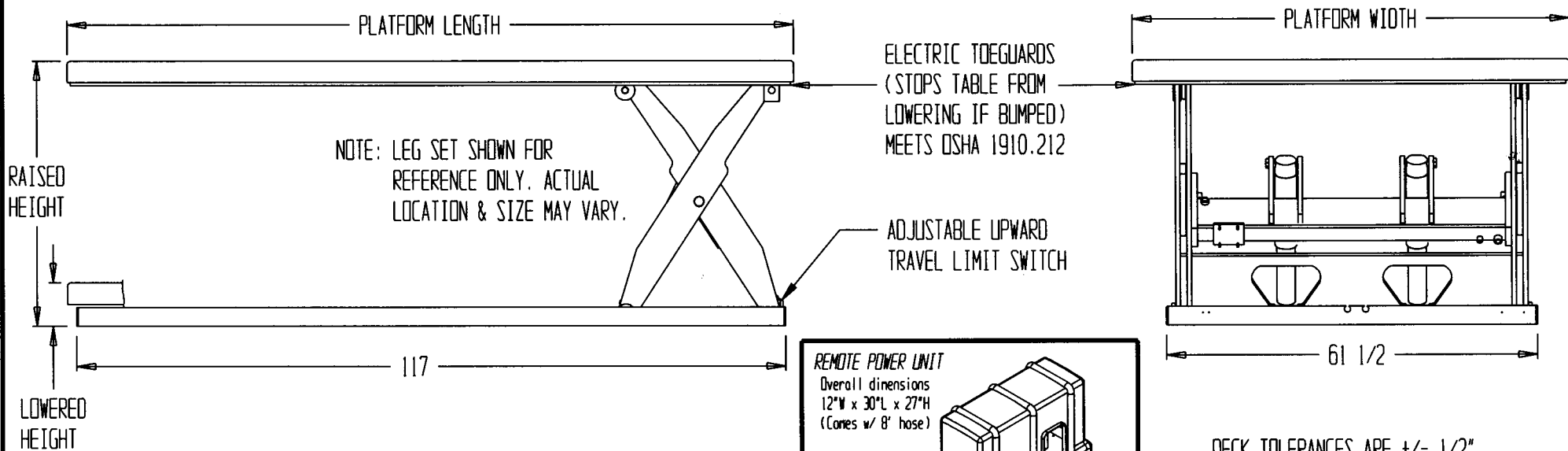

DECK TOLERANCES ARE +/- 1/2"  
TABLE HEIGHT TOLERANCES ARE +/- 1/2"

\*\*\* ALL GRAPHICS PROVIDED ARE FOR REFERENCE ONLY. IF CERTAIN DIMENSIONS ARE CRITICAL PLEASE VERIFY THOSE DIMENSIONS WITH YOUR SALESPERSON. \*\*\*

## STANDARD FEATURES:

- SCISSOR TABLE MODEL NUMBER IS BEHLT-72120-5-82
- PLATFORM WIDTH IS 72 INCHES
- PLATFORM LENGTH IS 120 INCHES
- PLATFORM RAISED HEIGHT IS 82 INCHES
- PLATFORM LOWERED HEIGHT IS 10 1/2 INCHES
- TABLE CAPACITY (EVENLY DISTRIBUTED LOAD) IS 5,000 LBS.
- STANDARD CONTROL IS 24 VOLT WEATHERTIGHT HAND PENDANT ON 8' CORD
- SAFETY MAINTENANCE PROPS
- DISPLACEMENT STYLE CYLINDERS INSTALLED ROD DOWN
- EMERGENCY SAFETY STOP HYDRAULIC FUSES IN ALL CYLINDERS
- 6.5 HP 208-230/460V 3 PHASE EXTERNALLY MOUNTED
- 2' TEST LEAD AND PIG TAIL

## SPECIAL FEATURES:

NONE

\*\*SPECIAL UNITS ARE NON-RETURNABLE  
\*AVAILABLE AT ADDITIONAL COSTS

\*\*Any additions, deletions or omissions must be corrected on this drawing, as this drawing will be considered all inclusive.\*\*

PRODUCTION WILL START UPON RECEIPT OF SIGNED APPROVAL DRAWING

## PLEASE CIRCLE SPECIFICATIONS:

POWER	<input checked="" type="checkbox"/> AC	<input type="checkbox"/> DC (12V)	<input type="checkbox"/> AIR/OIL
MOTOR VOLTAGE	<input checked="" type="checkbox"/> 115	<input type="checkbox"/> 208	<input type="checkbox"/> 230
DEDICATED CIRCUIT REQUIRED			
MOTOR PHASE	<input type="checkbox"/> SINGLE	<input type="checkbox"/> THREE	
CONTROL	<input type="checkbox"/> HAND	<input type="checkbox"/> *FOOT	
* BATTERY CHRG.	<input type="checkbox"/> REMOTE	<input type="checkbox"/> ON BOARD	
* CHRG. INDICATOR	<input type="checkbox"/> YES	<input type="checkbox"/> NO	
POWER UNIT LOCATION	<input type="checkbox"/> INTERNAL	<input type="checkbox"/> *EXTERNAL	

### APPROVAL

I, the undersigned, hereby approve this print  
 As drawn       As marked  
 This includes my approval of design & dimensions.  
 Signed: \_\_\_\_\_  
 Date: \_\_\_\_\_

<b>BEACON INDUSTRIES, INC</b>		P.O.#:
		W.O.#:
DRAWN BY: SR	DATE: 3-19-07	SALES:
REFERENCE:		DRWG./FILE NAME:
SCALE: 1:18		