

# A FRAME HOIST - BAHS SERIES

APPROX WEIGHT: 815.06 lbs.  
 DOES NOT INCLUDE WEIGHT OF POWER OR PACKAGING!!!

\*\*\* ANY ADDITIONS, DELETIONS, OR OMISSIONS MUST BE CORRECTED ON THIS DRAWING AS THIS DRAWING WILL BE CONSIDERED ALL INCLUSIVE \*\*\*

ALL GRAPHICS PROVIDED ARE FOR REFERENCE ONLY. IF CERTAIN DIMENSIONS ARE CRITICAL PLEASE VERIFY THOSE DIMENSIONS WITH YOUR SALESPERSON

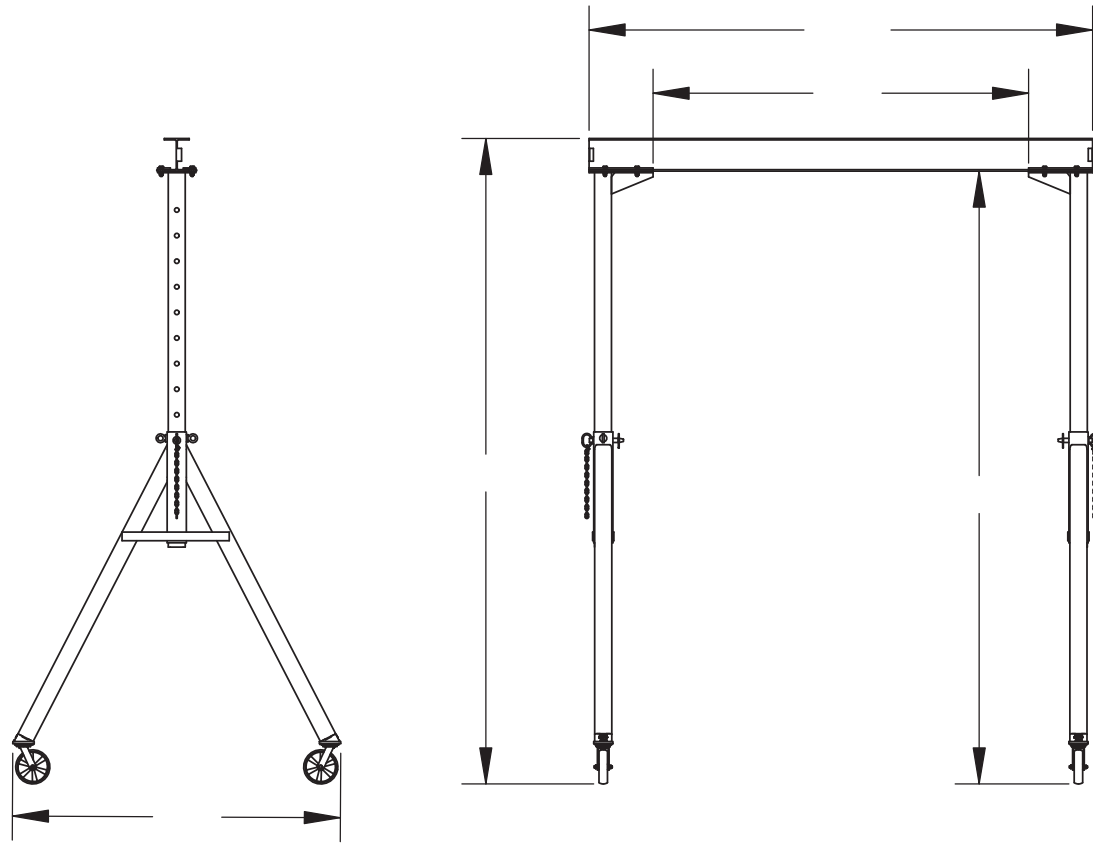

3D VIEW FOR REFERENCE ONLY

## STANDARD FEATURES

- MODEL NUMBER IS BAHS SERIES
- OVERALL WIDTH IS
- USABLE WIDTH IS
- OVERALL LENGTH IS
- USABLE LENGTH IS
- OVERALL HEIGHT IS
- UNDER I-BEAM HEIGHT IS TO
- CAPACITY IS
- OVERALL BEAM LENGTH IS
- OVERALL BEAM HEIGHT IS
- FLANGE WIDTH IS
- CASTERS: (4) 8" X 2" SWIVEL WITH FOUR LOCKING POSITION

\*\*CAPACITY OF ATTACHMENTS MAY DERATE CAPACITY OF GANTRY CRANE

APPROVAL	I, THE UNDERSIGNED, AGREE THAT THE PRODUCT AS REPRESENTED SATISFIES DESIGN AND DIMENSION REQUIREMENTS. I ALSO ACKNOWLEDGE MY DUTY TO CONFIRM PRODUCT AND INSTALLATION COMPLIANCE WITH ALL APPLICABLE FEDERAL, STATE AND LOCAL REGULATIONS AND STANDARDS. <b>ALL SPECIAL UNITS ARE NON-RETURNABLE</b> [ ] As drawn      [ ] As marked	
	Signed: _____ Date: _____	
LEAD TIME WILL START UPON RECEIPT OF SIGNED APPROVAL DRAWING		

BEACON INDUSTRIES, INC.		P.O.#
		W.O.#
DRAWN BY: ND	DATE: 10/1/09	SALES:
REFERENCE:	SCALE: 1:45	FILE NAME:
QUOTED LEAD TIME:	QUOTE # X	28-007-074