

**Ergonomic Solutions**

# OWNERS MANUAL

## FORKLIFT PLATFORM MODEL BWP

**Contents**

Warnings and Safety Instructions .....	1	Caster Installation .....	1
Receiving Instructions .....	1	Tine Lock Assembly/Operation .....	2
Warranty .....	1	Emergency Stop Option .....	2

**WARNINGS & SAFETY INSTRUCTIONS**

*Read owner's manual completely before operating unit!*

- Secure Work Platform to forklift before use.
- Ensure forklift forks are completely through fork pockets before use.
- Parking brake must be applied before elevating platform.
- Do not tilt mast forward. Forks must be level.
- Do not transport personnel when elevated. (max. transport speed 4 m.p.h.)
- Install engine shut off switch on platform if being used in potentially noisy areas.
- Inspect locks, hooks, and chains before each use. Do not use if damaged.
- Secure safety belt (or harness) to work platform
- Ensure locks, gates and chains are secured before elevating.
- Do not lean against gate or climb on side rails.
- Uniform floor load capacity is 1,000 pounds.
- Observe OSHA/scaffolding laws.
- Operate with trained personnel only.
- Operate only on level ground.
- Do not use near live high voltage.
- Fork truck manufacturers shall be consulted when additions are made affecting capacity and safe operation. See OSHA 1910.178 (a)4.

and workmanship. The manufacturer's obligation hereunder is limited to repairing such products during the warranty period, provided the product is sent prepaid back to the factory.

This warranty does not cover normal wear of parts or damage resulting from any of the following: negligent use or misuse of the product, use or application contrary to installation instructions, or disassembly, repair or alteration by any person prior to authorization from a factory representative.

**CASTER INSTALLATION**

- 1.) Slide caster into caster plate
- 2.) Run bolt thru caster pad and attach nut on the other side.
- 3.) Repeat the above steps for each caster.

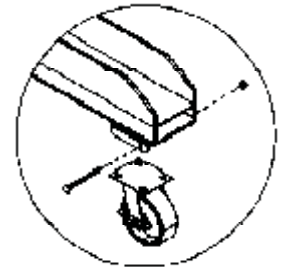

*\* For control purposes keep the swivel casters at the end where the operator will be pushing the unit.*

**RECEIVING INSTRUCTIONS**

Every unit is thoroughly tested and inspected prior to shipment. However, it is possible that the unit may incur damage during transit. If you see damage when unloading make a note of it on the SHIPPER RECEIVER.

Remove all packing and strapping material and inspect unit for damage. IF DAMAGE IS EVIDENT, FILE A CLAIM WITH THE CARRIER IMMEDIATELY!

**WARRANTY**

This product is warranted for 90 DAYS from date of purchase to be free of manufacturing defects in material

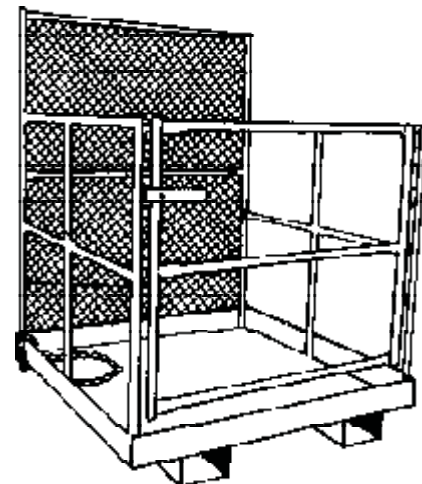

**FORKLIFT PLATFORM  
MODEL BWP**

## ENGAGING TINE LOCK INTO POSITION

- 1.) Slide forks thru fork pockets on Work Platform
- 2.) Go back by the heel of the right fork
- 3.) Pull pin and rotate tine lock 90°
- 4.) Pin is then engaged in locking hole securing fork

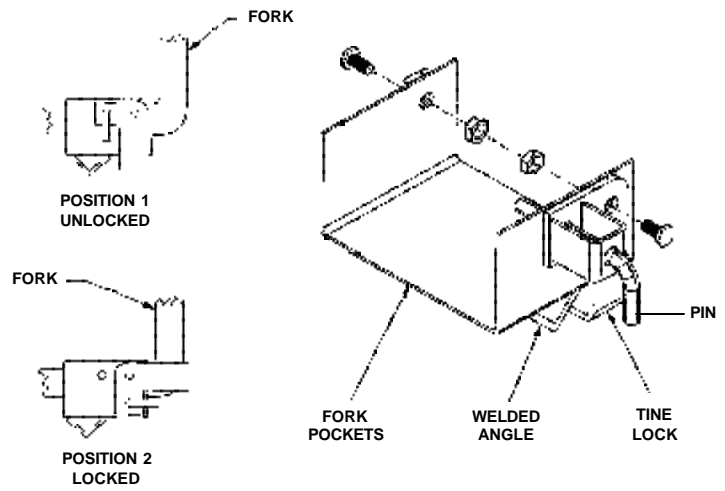

## EMERGENCY STOP BUTTON OPTION

### MATERIALS INCLUDED

Qty.	Description
8	1/4 - 20 x 1 Machine Bolt
8	1/4 - 20 Lock Nut
8	1/4 Flat Washer
4	1/4 Fender Washer
1	Fork Truck Junction Box (pre-assembled)
1	Work Platform Junction Box (pre-assembled)

### INSTALLATION INSTRUCTIONS

#### GAS POWERED FORK TRUCKS

- 1.) Mount the supplied 4" square junction box with the short pig tail near the front of the fork truck (see figure "A") using the 1/4"-20 x 1" machine bolts and lock nuts provided.
- 2.) Disconnect the wire on the key switch coming from the ignition coil and attach it to one of the receptacle terminals inside the junction box which was previously mounted on the fork truck.
- 3.) Connect a wire from the ignition key switch to the other receptacle terminal inside of the fork truck mounted junction box.
- 4.) Mount the "Emergency Stop" junction box inside the work platform within easy reach of the operator/maintenance person.

NOTE: Fork Trucks powered by BATTERY or DIESEL FUEL, contact the FORK TRUCK manufacturer for installation instructions.

### OPERATING INSTRUCTIONS

#### FOR USE WITHOUT THE WORK PLATFORM ATTACHED

- 1.) Plug in the 12" long jumper plug into the fork truck mounted junction box. This will provide the necessary connection for operation with out the work platform attached to the fork truck.
- 2.) Plug the 20' coil cord into the fork truck mounted junction box. This will provide the necessary connection for operation with the work platform attached up to 20". (The mushroom head push button must be pulled out.)

