

**Ergonomic Solutions**

# OWNER'S MANUAL

## MOBILE ELEVATING TABLE MODEL BSCTAB-750D

**Contents**

Warnings and Safety Instructions .....	1	Trouble Shooting Guide .....	5
Receiving Instructions .....	1	Hydraulic Schematic .....	5
Loading Instructions .....	2	Speed Selection For Foot Pump .....	5
Installation Instructions .....	2	Scissor Table Exploded Parts Drawing .....	6
Periodic Maintenance Instructions .....	2	Parts List .....	7
Parts Diagram For Foot Pump .....	3	Warning Label Identification .....	8
Operating Instructions .....	3	Material Safety Data Sheet .....	9-10
Parts Identification For Foot Pump .....	4	Limited Warranty/Service Record .....	11
Air Bleed Procedure .....	4	Material Handling Problem Solvers .....	34

**WARNINGS & SAFETY INSTRUCTIONS**

*Read owner's manual completely before operating unit!*

- Not a personnel lift. Keep clear when operating.
- Never operate lift unless you are watching it.
- Never exceed the maximum loading capacity of 750 lbs.
- Always operate unit on a level surface to insure stability.
- Load lift as uniformly as possible.
- Consult factory for uneven loading.
- Do not continue to step on the foot pump if deck is not raising.
- Do not change pressure relief valve setting.
- Relieve system pressure by depressing foot lever after unit has come to rest.
- Do not clamp cylinder in a vise as you may distort barrel.
- Never go under deck if there is weight on unit.
- Remove weight before working on unit.
- Use only maintenance parts supplied or approved by the manufacturer.
- Consult factory if adding or performing any modification to the original equipment.
- Do not use brake fluids or jack oils.  
Use AW-32 Hydraulic oil or equal.
- Make sure all operator safety labels are in place (p.8).

Remove all packing and strapping material, inspect for damage. IF DAMAGE IS EVIDENT, FILE A CLAIM WITH THE CARRIER IMMEDIATELY! Also, check the platform size, type of power unit, etc., to ensure that the unit is correct for the intended application.

**MODEL NUMBER AND CAPACITY**

The model number, serial number and capacity are inscribed on the nameplate. Please remember to include these numbers in any correspondence with your dealer or the factory.

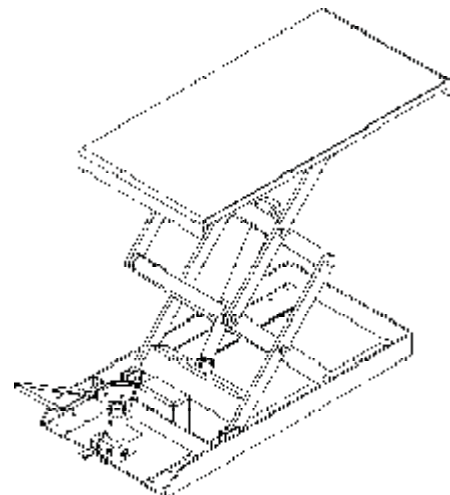

**FOOT PUMP SCISSOR TABLE  
MODEL BSCTAB-750D**

**RECEIVING INSTRUCTIONS**

Every unit is thoroughly tested and inspected prior to shipment. However, it is possible that the unit may incur damage during transit. If you see damage when unloading make a note of it on the SHIPPER RECEIVER.

## LOADING INSTRUCTIONS

The load capacity rating as inscribed on the nameplate of your unit designates the net capacity, assuming the load is centered on the deck. This capacity must never be exceeded, as permanent damage or injury may result.

## INSTALLATION INSTRUCTIONS

### Review Complete Owner's Manual Before Commencing Installation

For installation you will need the following:

- 1.) A fork truck or hoisting means.
- 2.) Lag bolts, masonry drill, masonry bit, wrench for lag bolt, grout, and steel shims.

Move the lift with straps or forks under frame.

Read all the warning labels on the lift.

Check local codes pertaining to your application.

Be sure maintenance stop is in position before getting under platform.

After anchoring to floor, shim or grout the full length on the frame sides.

Operate lift through a few cycles. Check and add oil if necessary. See oil specifications under Periodic Maintenance Instructions.

## Ordering Replacement or Extra Parts

Our company takes pride in using the finest available parts for our equipment. We are not responsible for equipment failure resulting from the use of unapproved replacement parts. To order replacement or extra parts for your equipment contact Customer Service at the factory. In any correspondence with the factory please include the **Serial Number** which is inscribed on the nameplate of the piece of equipment. Use only the part numbers provided in this Owner's Manual. When ordering parts for AC power units please indicate the motor phase and voltage that the equipment is operating on.

## PERIODIC MAINTENANCE INSTRUCTIONS

### (A) Before Each Use Check For The Following:

- 1.) Oil leaks
- 2.) Pinched or chafed hoses
- 3.) Structural deformation of legs or deck
- 4.) Unusual noise or binding

**Do not use if there are any of the above!**

### (B) Monthly Inspections

- 1.) Check oil level. Oil should be 1" to 1-1/2" below the top of the tank with the lift in the fully lowered position. Add as necessary. (Check oil more frequently for high use application)
- 2.) Check for oil leaks.
- 3.) Check pivot points for wear.
- 4.) Check for worn or damaged hydraulic hoses. Repair as necessary.
- 5.) Check rollers for looseness and wear. See Trouble Shooting Section.
- 6.) Check retaining rings at load rollers.
- 7.) Check for unusual noise. See Trouble Shooting Section.
- 8.) Make sure all warning labels are in place and in good condition.
- 9.) Clean off dirt and debris.

### (C) Yearly Inspection

Hydraulic oil should be changed at least once a year, or sooner if the oil darkens or becomes gritty. Flush reservoir before refilling. Presence of water is indicated if the oil turns milky. Recommended oil: AW-32 Hydraulic fluid or equal.

**All maintenance work must be performed by personnel who are trained and qualified to do the intended work.**

## Parts Diagram for Single and Two-Speed Hydraulic Foot Pumps

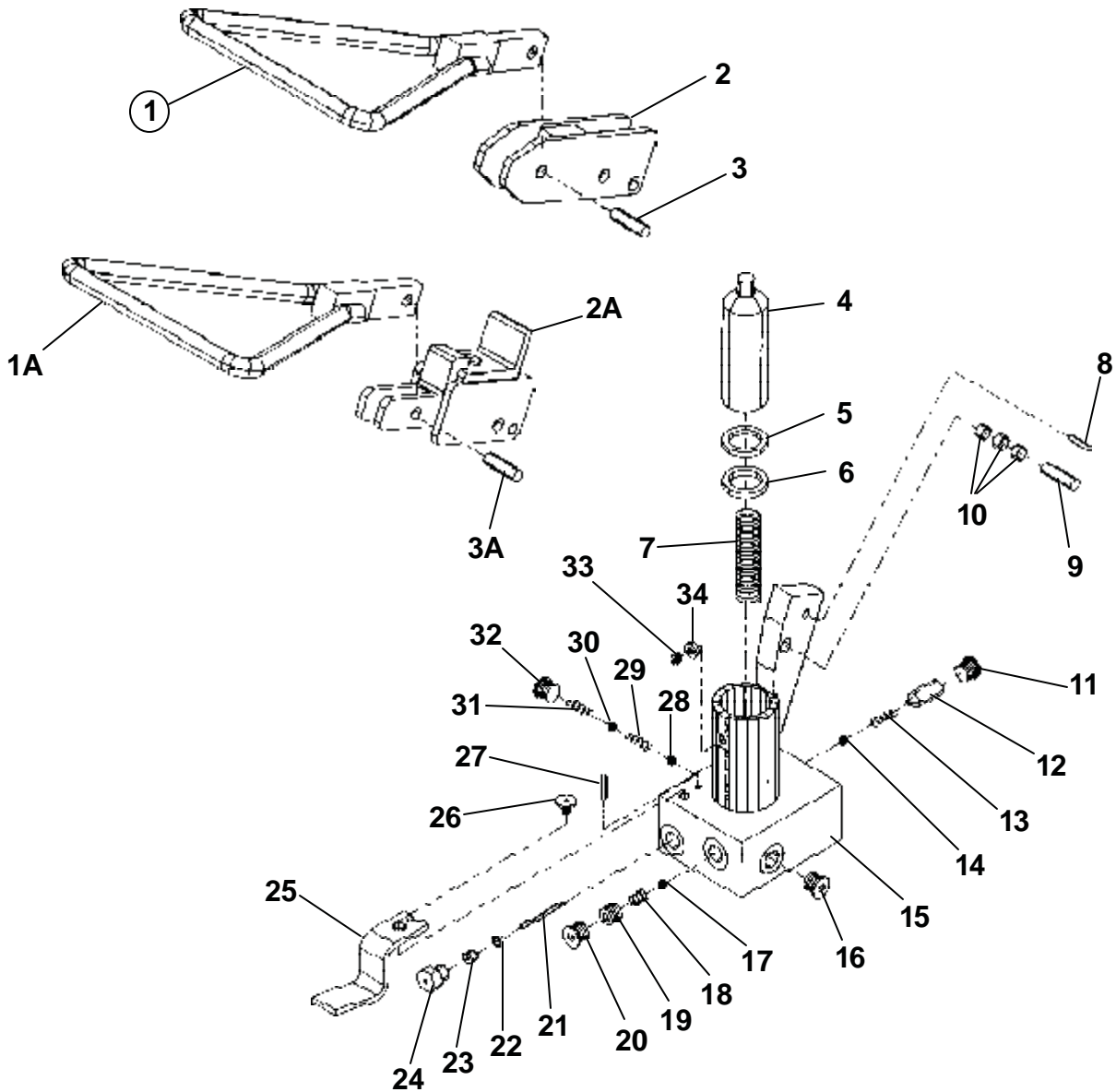

### Operating Instructions

#### Features:

Your new lift equipment has been supplied with an exclusive single-speed or two-speed foot pump. The internal features of your pump include a primary pressure relief, pressure compensated return flow control valve, and an integrated lowering valve. Replaceable bushings, valve components, and seals have been utilized in the construction of the pump in the event that replacements are necessary.

#### Operating Instructions:

Stay clear of moving parts. The deck will rise as the foot pedal is pumped. Depressing the release lever will lower the table at a controlled rate of descent.

In the event the deck has been overloaded, the pressure relief will open because of excessive pressure build-up in the hydraulic system. Oil will bypass into the reservoir. **Never** increase the pressure relief setting more than necessary. **Do not** exceed the rated capacity of your lift equipment.

#### Two-Speed Selection:

The two-speed hydraulic foot pump offers two "speeds". The low speed produces *low volume/high pressure*. The high speed produces *high volume/low pressure*. The operator has the option of selecting the optimum pump speed for the application at hand. Pump speeds are selected by sliding the "lock collar"(Item # 2 on the parts identification) in or out. An occasional drop of oil will keep the collar working freely.

## Parts Identification for Single and Two-Speed Hydraulic Foot Pumps

KIT NO.	ITEM NO.	DESCRIPTION	ENGINEER NUMBER	PART NUMBER	QTY.
	1	Assembly, lever delta foot pedal, double speed	B01-540-003	BSCTAB750-DSFP	1
	1A	Assembly, lever delta foot pedal, single speed	B01-540-004	BSCTAB750-SSFP	1
	2	Linkage for single-speed foot pump	BHFP-LNK1	BHFP-LNK1	1
	2A	Linkage for two-speed foot pump	BHFP-LNK2	BHFP-LNK2	1
	3	3/8" x 1-3/4" dia. detent pin	B01-130-004	BHFP-DPIN1	1
	3A	3/8" x 1-1/4" dia. detent pin	B01-130-005	BHFP-DPIN2	1
	4	Pump plunger	B01-041-001	BHFP-PP	1
A	5	Piston wiper seal	B550110	a/k	1
A	6	Piston U-cup seal	B532101	a/k	1
	7	Piston return spring	B01-146-004	BHFP-SPG1	1
	8	1/4" x 1-1/2" spring pin	B64251	BHFP-RLPIN	1
	9	3/8" x 1-3/4" dia. Driv-Loc pin	B01-130-004	BHFP-DLPIN	1
	10	Sleeve sintered bronze bearing	B01-111-038	BHFP-BBRG	3
C	11	Fitting, "O"-ring plug	B01-116-007	a/k	1
C	12	Pressure compensated flow control valve	B01-153-007	a/k	1
C	13	Release check spring	B01-146-002	a/k	1
C	14	5/16" dia. steel ball	B01-145-001	a/k	1
	15	Pump body/manifold	BHFP-BDYMAN	BHFP-BDYMAN	1
	16	Fitting, "O"-ring plug	B01-116-007	BHFP-FTGO	1
	17	3/8" dia. chrome steel ball	B01-145-003	BHFP-CBALL3	1
	18	Pressure relief spring	B01-146-005	BHFP-SOG2	1
A	19	Fitting, pressure adjustment plug	B01-116-006	BHFP-FTGPAP	1
	20	Fitting, "O"-ring plug	B01-116-007	BHFP-FTGO	1
B	21	Release pin	B01-112-016	a/k	1
A,B	22	Release pin seal retaining ring	B565011	a/k	1
A,B	23	Release rod U-cup seal	B01-144-002	a/k	1
B	24	Fitting, hydraulic plug	B01-116-004	a/k	1
B	25	Release lever	B01-040-001	a/k	1
B	26	Release lever retaining screw	B01-119-001	a/k	1
B	27	3/16" x 1-1/8" spring pin	B64134	a/k	1
	28	5/16" dia. chrome steel ball	B01-145-001	BHFP-SBALL	1
	29	Inlet check spring	B01-146-001	BHFP-SPG	1
	30	7/16" dia. chrome steel ball	B01-145-004	BHFP-CBALL4	1
	31	Outlet check spring	B01-146-001	BHFP-SPGO	1
	32	Fitting, "O"-ring plug	B01-116-007	BHFP-FTGO	1
	33	1/4" -20 x 1/4" socket head cap screw	B562008	BHFP-SHCS	1
A	34	1/4" sealing washer (copper with rolled core)	B577004	a/k	1
	A	Foot Pump Rebuild Kit (includes 5,6,19,22,23,&34)	B01-136-403	BHFP-K-A2	1
	B	Pressure Release Kit (includes 21-27)	B01-154-005	BHFP-K-B2	1
	C	Flow Control Kit (includes 11-14)	B01-154-006	BHFP-K-C2	1

a/k Available only with purchase of kit

### Air Bleed Procedure

Whether your pump is a new installation, or has been recently serviced, air has likely entered the hydraulic system. The design of this pump includes an "air bleed screw" which will aid in the removal of unwanted air from the foot pump area of the hydraulic system. Use the following steps to remove this air from the system.

- 1) Check all fittings to be sure they are tight. Ensure that the oil is filled to within 1" of the top of the reservoir when the lift is in the fully lowered position.
- 2) Locate the "air bleed screw"( Item # 34 on the pump body) and loosen approximately 1/2 turn counterclockwise. As soon as you have loosened the screw, slowly depress the foot pedal. This will force the air out of the pump chamber. Before you let the pump pedal return to the "up" or "home" position, tighten the air bleed screw. This will prevent air from re-entering the pump chamber. Repeat the above procedure until the pump chamber is completely filled with oil and a "spongy" feel is no longer present. If the air bleeding procedure has been successful, the feel of the pump pedal will be firm and the complete stroke of the pump will produce fluid flow.

Air can also become trapped in the hydraulic cylinder(s). Repeat the above procedures for air removal instructions.

# Trouble shooting Guide for Single and Two-speed Hydraulic Foot Pump

Observation	Possible Cause	Remedy	<i>*Refer to exploded view</i>
1.) Deck does not raise	a. Excessive load b. Oil is low  c. Pinched hose d. Relief valve set too low	a. Remove part of the load b. Fill oil to within one inch of the top of the reservoir c. Correct as necessary d. Increase only as necessary	
2.) Foot pedal goes down hard but deck does not raise	a. Particle of dirt under the pressure relief b. Particle of dirt under inlet check	a. Lower deck- Disassemble, clean and reassemble pressure relief* b. Lower deck- Disassemble, clean and reassemble inlet check valve*	
3.) Unit will pump under no load or when rapidly stroked, or pedal will stroke with out pumping	a. Pump is air locked b. Inlet check valve has foreign material on seat c. Relief setting is out of adjustment d. Foreign material on relief valve seat	a. Bleed air from system inlet b. Remove and clean inlet ball and seat c. Adjust relief setting higher d. Lowering valve has foreign material on the seat or is stuck in the open position	
4.) Deck raises when the pump is stroked but lowers on return stroke	a. Outlet check is leaking	a. Clean foreign material from ball and seat	
5.) Deck raises but takes too much effort	a. Change pump displacement speed	a. Slide locking collar back	
6.) Deck raises but is too slow	a. Change pump displacement speed b. Intake filter clogged  c. Foreign material stuck under pressure relief valve or under inlet check valve	a. Slide locking collar forward b. Lower deck- drain reservoir, clean and flush debris, refill with clean oil c. Lower deck- Disassemble, clean and reassemble pressure relief*	
7.) Spongy or jerky operation	a. Check for foreign material stuck in the deck or frame rails b. Oil is low	a. Correct as necessary b. Fill oil to within one inch of the top of the reservoir	
8.) Deck lowers too slowly	a. Pinched hose b. Intake filter clogged c. Foreign material lodged in velocity fuse  d. Foreign material lodged in pressure compensated flow control valve	a. Correct as necessary b. Correct as necessary c. Lower deck- Disassemble, clean and reassemble* d. Lower deck- Disassemble, clean and reassemble pressure relief*	
9.) Deck lowers too fast	a. Foreign material lodged in pressure compensated flow control valve	a. Lower deck- Disassemble, clean and reassemble pressure relief*	
10.) Deck raises but does not lower	a. Foreign material lodged in pressure compensated flow control valve b. Release pin bent or missing c. Foreign object blocking roller travel d. Velocity fuse is locked	a. Lower deck- Disassemble, clean and reassemble pressure relief* b. Replace as necessary c. Correct as necessary d. Remove air from hydraulic system, to unlock, repressurize system (refer to hydraulic schematic in manual)	

## HYDRAULIC SCHEMATIC

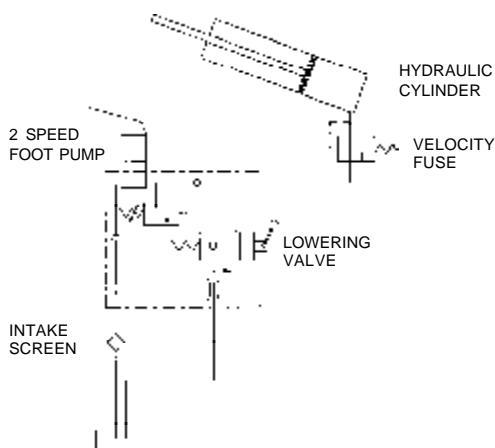

## Speed Selection for Two-Speed Hydraulic Foot Pump

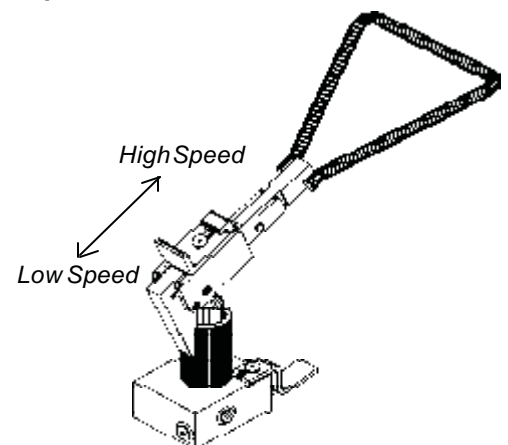

**FOOT PUMP SCISSOR LIFT  
MODEL BSCTAB-750D**

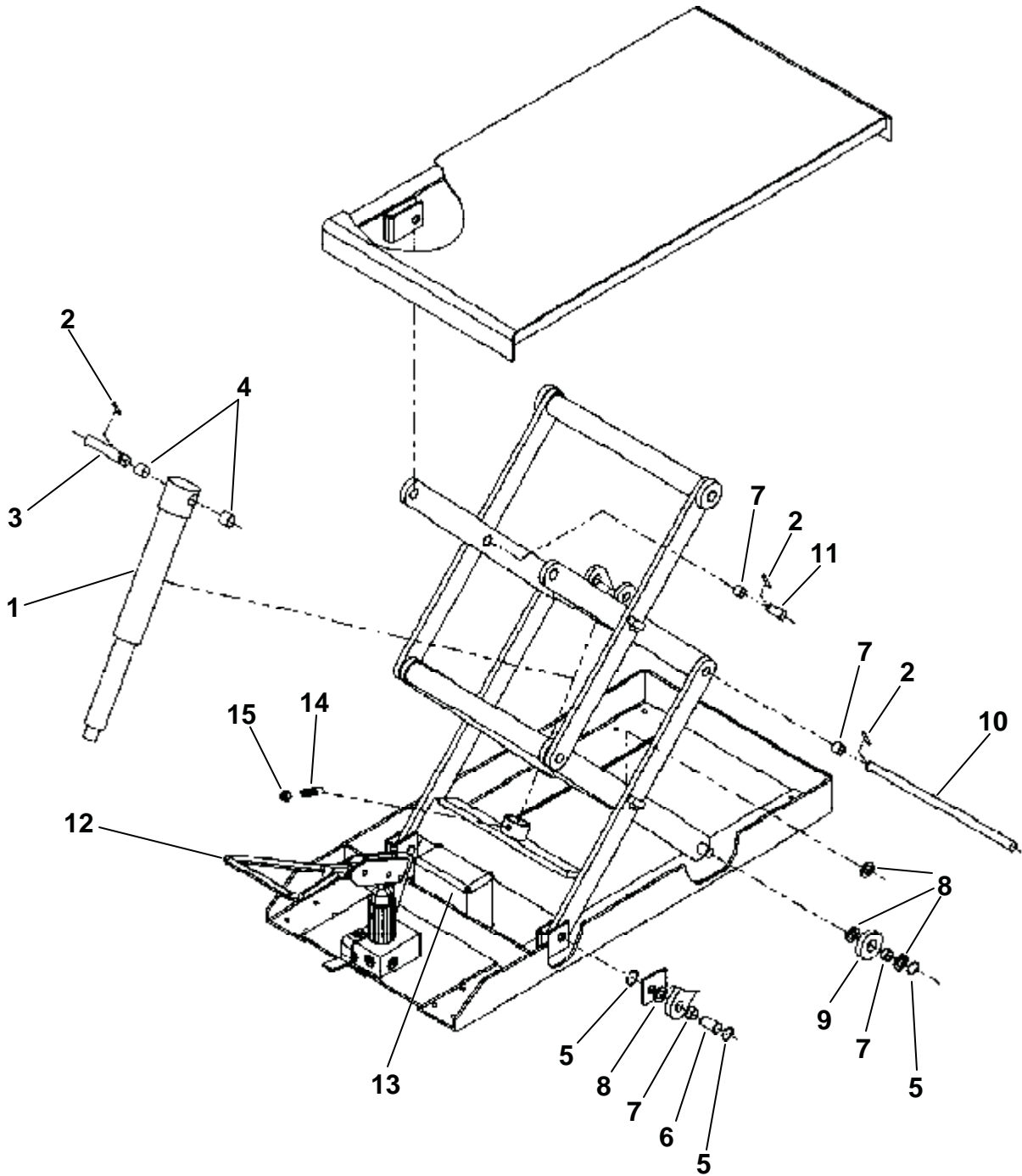

**PARTS IDENTIFICATION**  
**FOOT PUMP SCISSOR LIFT (MODEL BSCTAB-750D)**

KIT	ITEM NO.	DESCRIPTION	ENGINEER NO.	PART NO.	QTY.
	1	Hydraulic cylinder, 1-1/2" dia. x 7"	B01-021-010	a/k	1
A,D	2	Spring pin, 3/16" dia. x 1-1/8"	a/k	a/k	7
A	3	Cylinder mounting pivot pin, 3/4" dia. x 4-1/6"	B01-112-010	a/k	1
A	4	Cylinder mounting bushing, 3/4" ID x 3/4"	B01-111-009	a/k	2
C,B	5	External retaining ring, 3/4" shaft dia.	B01-117-002	a/k	12
B	6	Hinge pin, 3/4" dia. x 1.41"	B01-112-009	a/k	4
B,C,D	7	Bushing, 3/4" ID x 1/2"	B01-111-008	a/k	16
B,C	8	Machinery bushing, 3/4"ID x 1-1/4"OD x 18 ga.	B33424	a/k	16
C	9	Roller	B01027002	a/k	4
D	10	Journal pin, 3/4" dia. x 17.38"	B01-112-011	a/k	2
D	11	Main axle pin, 3/4" dia. x 1.69"	B01-112-012	a/k	4
	12	Foot pump	B01-640-003	BSCTAB750-FP	1
	13	Reservoir	B01-023-002	BSCTAB750-RES	1
A	14	Cylinder retainer bolt	B01-118-001	a/k	1
A	15	Jam nut, 1/2"-13	a/k	a/k	1
	16	Hydraulic hose w/ fittings, 1/8" ID x 32" (not shown)	B01-623-005	BSCTAB750-HH	1
	17	Reservoir hose w/ fittings, 3/8" ID x 10" (not shown)	B01-623-006	BSCTAB750-RH	1
A		Hydraulic Cylinder Kit (2,3,4,14,15)	B01-154-001	BSCTAB750-KITA	1
B		Rear Pivot Pin Kit (5,6,7,8)	B01-154-002	BSCTAB750-KITB	1
C		Front Roller Kit (5,7,8,9)	B01-154-003	BSCTAB750-KITC	1
D		Leg Pin Kit (includes 2,7,10,11)	B01-154-004	BSCTAB750-KITD	1

a/k Available only in Kit

# WARNING LABEL IDENTIFICATION

MAKE SURE ALL WARNING LABELS ARE IN PLACE!

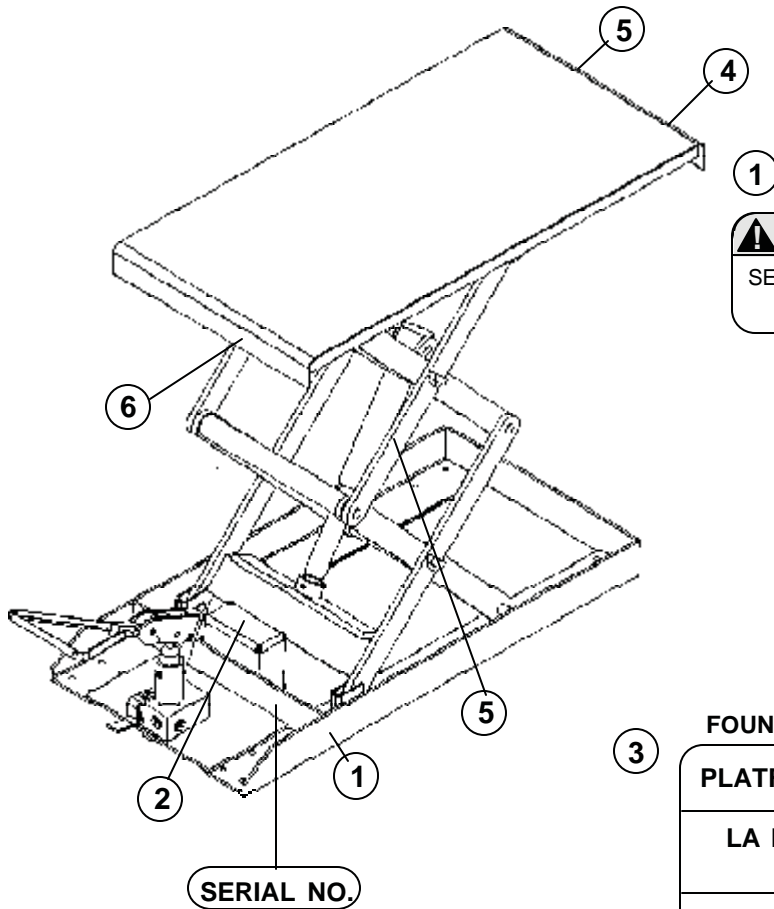

<b>WARNING</b>	<b>AVISO</b>	<b>AVERTISSEMENT</b>
SECURE FRAME TO FLOOR	ASEGURE EL BASTIDOR AL PISO	FIXER SOLIDEMENT LE CADRE AU PLANCHER

204

2 ON HYDRAULIC TANK (NOT SHOWN)

ISO AW-32

HYDRAULIC OIL OR EQUIVALENT  
ACEITE HIDRÁULICO O EQUIVALENTE  
HYDRAULIQUE OU ÉQUIVALENT

206

3 FOUND ON HANDLE  
PLATFORM MUST BE LOWERED BEFORE MOVING LIFT

LA PLATAFORMA DEBE DE SER BAJADA ANTES DE  
MOVER EL MONTACARGAS

LA PLATE-FORME DOIT ÊTRE ABAISSÉE AVANT  
D'ACTIVER LE MONTE-CHARGE

210

\*Product safety signs or labels should be periodically inspected and cleaned by the product users as necessary to maintain good legibility for safe viewing distance . . .  
ANSI 535.4 (10.21)  
Contact manufacturer for replacement labels if needed.

4

FOR USER INSTRUCTIONS OR QUESTIONS CONTACT  
PARA INSTRUCCIONES DE USO Ó CONSULTAS CONTACTAR  
POUR INSTRUCTIONS OU QUESTIONS SUPPLÉMENTAIRES CONTACTER

205

5 BOTH SIDES & FRONT END

<b>WARNING</b>	<b>AVISO</b>	<b>AVERTISSEMENT</b>
KEEP CLEAR OF PINCH POINT	MANTENGASE ALEJADO DE PUNTO DE CORTE	SE TENIR À DISTANCE DU POINT DE PINCEMENT

208

6

<b>DANGER</b>	TO AVOID PERSONAL INJURY READ OWNER'S MANUAL BEFORE OPERATING OR REPAIRING SCISSOR LIFT		DO NOT PUT HANDS, FEET OR OBJECTS UNDER TOP. LOWER PLATFORM SLOWLY.		DO NOT WORK UNDER LIFT WITHOUT SAFETY BLOCK OR WHILE LOADED. KEEP CLEAR OF MOVING SCISSOR LEG MECHANISM.		DO NOT STAND, SIT OR RIDE ON LIFT
<b>PELIGRO</b>	PARA EVITAR DAÑOS PERSONALES LEA EL MANUAL DEL PROPIETARIO ANTES DE OPERAR O REPARAR EL ELEVADOR DE TIJERAS		NO PONGA MANOS, PIES U OBJETOS DEBAJO DEL BORDE. DESCienda LA PLATAFORMA LENTAMENTE.		NO TRABAJE DEBAJO DEL ELEVADOR SIN LOS FRENOS DE SEGURIDAD O CUANDO ESTE CARGADO. MANTENGASE ALEJADO DEL MECANISMO DE TIJERA EN MOVIMIENTO.		NO SE SIENTE, SE PARE, O VIAJE EN EL ELEVADOR
<b>ATTENTION</b>	POUR ÉVITER TOUTE BLESSURE PERSONNELLE LIRE LE MANUEL D'UTILISATION AVANT DE METTRE EN MARCHÉ OU AVANT DE RÉPARER L'ÉLEVATEUR CISEAU		NE PAS METTRE LES MAINS, LES PIEDS OU TOUT OBJET SOUS LE PLATEAU SUPÉRIEUR. DESCENDRE LA PLAT-FORM LENTEMENT		NE PAS TRAVAILLER SOUS L'ÉLEVATEUR SANS BLOCS DE SÉCURITÉ OU LORSQU' IL EST CHARGÉ. RESTER À L'ÉCART DU MÉCANISME CISEAU LORSQUE L'ÉLEVATEUR EST EN FONCTIONNEMENT.		NE PAS SE TENIR DEBOUT, S'ASSEoir OU MONTER SUR L'ÉLEVATEUR

207

8



---

# LIMITED WARRANTY

**ONE YEAR LIMITED WARRANTY.** The manufacturer warrants for the original purchaser against defects in materials and workmanship under normal use one year after date of purchase. (Not to exceed 15 months after date of manufacture.) Any part which is determined by the manufacturer to be defective in material or workmanship and returned to the factory, shipping costs prepaid, will be, as the exclusive remedy, repaired or replaced at our option. Labor costs for warranty repairs and/or modifications are not covered unless done at manufacturer's facilities. Any modifications performed without written approval of the manufacturer may void warranty. This limited warranty gives purchaser specific legal rights which vary from state to state.

**LIMITATION OF LIABILITY.** To the extent allowable under applicable law, the manufacturer's liability for consequential and incidental damages is expressly disclaimed. The manufacturer's liability in any event is limited to, and shall not exceed, the purchase price paid. Misuse or modification may void warranty.

**WARRANTY DISCLAIMER.** Our company has made a diligent effort to illustrate and describe the products shown accurately; however, such illustrations and descriptions are for the sole purpose of identification, and do not express or imply a warranty that the products are merchantable, or fit for a particular purpose, or that the products will necessarily conform to the illustrations or descriptions.

The provisions of the warranty shall be construed and enforced in accordance with the UNIFORM COMMERCIAL CODE and laws as enacted in the State of Indiana.

**DISPOSITION.** Our company will make a good faith effort for prompt correction or other adjustment with respect to any product which proves to be defective within the Limited Warranty. Warranty claims must be made in writing within said year.

---

## SERVICE RECORD

DATE OF SERVICE: ____/____/____
WORK DONE BY: _____
SERVICE PERFORMED: _____
_____
_____

DATE OF SERVICE: ____/____/____
WORK DONE BY: _____
SERVICE PERFORMED: _____
_____
_____

DATE OF SERVICE: ____/____/____
WORK DONE BY: _____
SERVICE PERFORMED: _____
_____
_____

DATE OF SERVICE: ____/____/____
WORK DONE BY: _____
SERVICE PERFORMED: _____
_____
_____

DATE OF SERVICE: ____/____/____
WORK DONE BY: _____
SERVICE PERFORMED: _____
_____
_____

DATE OF SERVICE: ____/____/____
WORK DONE BY: _____
SERVICE PERFORMED: _____
_____
_____