

Ergonomic Solutions

OWNER'S MANUAL

PANEL CART • MODEL BPRCT

Contents	
Safety Precautions	1
Receiving Instructions	1
Warranty	1
Assembly Instructions	1
Assembly & Parts Drawing	2
Parts List	2
Warning Label Identification	2

SAFETY PRECAUTIONS

Read owner's manual completely before operating unit!

- Never exceed the maximum capacity of 2,000 pounds.
- Load must be evenly distributed on platform to insure stability.
- Always apply wheel brakes when unit is not being moved.
- Always operate unit on a level surface to insure stability.
- Use caution in moving a loaded unit; avoid obstructions and floor defects.
- Make sure all operator safety labels are in place (p.2).

RECEIVING INSTRUCTIONS

Every unit is thoroughly tested and inspected prior to shipment. However, it is possible that the unit may incur damage during transit. If damage is noticed when unloading, make a note of it on the BILL OF LADING. Remove all packing and strapping material, then inspect the unit again for damage. IF DAMAGE IS EVIDENT, FILE A CLAIM WITH THE CARRIER IMMEDIATELY!

WARRANTY

This product is warranted for 90 DAYS from date of purchase to be free of manufacturing defects in material and workmanship. The manufacturer's obligation hereunder is limited to repairing such products during the warranty period, provided the product is sent prepaid back to the factory.

This warranty does not cover normal wear of parts or damage resulting from any of the following: negligent use or misuse of the product, use or application contrary to installation instructions, or disassembly, repair or alteration by any person prior to authorization from a factory representative.

ASSEMBLY INSTRUCTIONS

- 1.) Remove top basket retainer from base of panel cart. Slide down on the four upright posts in the center section of the cart base. (Loosen nuts and bolts on basket assembly if necessary for adjustment to fit.)
- 2.) Install two swivel casters on the same end of base as the rollers brackets, and two rigid casters on the other end. Place caster base plate into caster pad bracket and insert 3/8" UNC x 5" carriage bolt through the square hole in caster pad to hold caster in place (Make sure head of carriage bolts towards inside of table). Place 3/8" UNC locknut on each bolt and tighten securely.
- 3.) Return to upright position and lock swivel casters.
- 4.) Place black roller between brackets and insert 1/2" dia. roller pin provided through brackets and roller, leaving an equal length on each end. Tap on locking end caps to both ends of rod. Unlock wheel.

(Please refer to the next page for the assembly drawing)

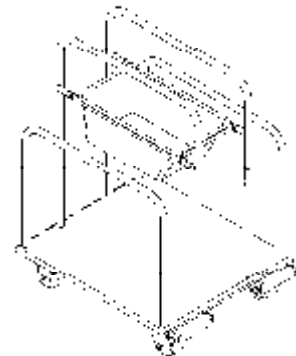

PANEL CART • MODEL BPRCT

PANEL RACK CART • MODEL BPRCT
Assembly & Parts Drawing

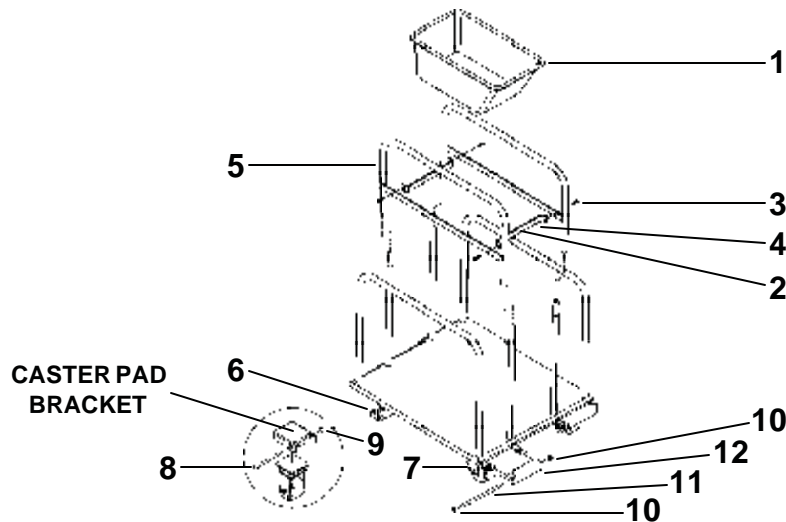

PARTS IDENTIFICATION
PANEL CART • MODEL BPRCT

KIT NO.	ITEM NO.	DESCRIPTION	ENGINEER NO.	PART NO.	QTY.
B	1	Basket	B16-048-001	BPC-BSK	1
B	2	Basket bar	B16-016-052	BPC-BBSKTBR	2
A,B	3	Bolt, 5/16"-18 UNC x 1"	a/k	a/k	4
A,B	4	Nylock nut, 5/16"-18 UNC	a/k	a/k	4
	5	Middle frame	B16-514-006	BPC-MIDFM	2
C	6	Wheel, (rigid caster)	B16-132-016	BPC-CASR	2
C	7	Wheel, (swivel caster w/ brake)	B16-132-015	BPC-CASBK	2
A,C	8	Carriage bolt, 3/8"-16 UNC x 5"	a/k	a/k	4
A,C	9	Nylock nut, 3/8"-16 UNC	a/k	a/k	4
D	10	End cap	B16-130-001	BPC-ECAP	4
D	11	Roller pin	B16-112-002	BPC-RPIN	2
D	12	Roller	B16-027-001	BPC-RLLR	2
	A	Bolt Kit (includes 3, 4, 8, 9)	B16-154-004	BPC-KIT-A	1
	B	Basket Kit (includes 1,2,3,4)	B16-154-005	BPC-KIT-B	1
	C	Wheel Kit (includes 6,7,8,9)	B16-154-006	BPC-KIT-C	1
	D	End Roller Kit (includes 10,11,12)	B16-154-007	BPC-KIT-D	1

a/k Available only with purchase of kit

WARNING LABEL IDENTIFICATION

MAKE SURE ALL WARNING LABELS ARE IN PLACE!

* Product safety signs or labels should be periodically inspected and cleaned by the product users as necessary to maintain good legibility for safe viewing distance. ANSI 535.4 (10.21) Contact manufacturer for replacement labels.

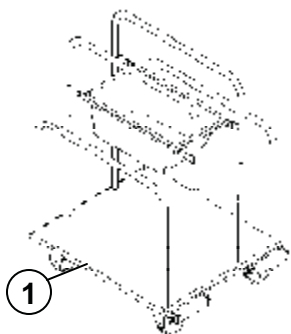

①

CAUTION	PRECAUCIÓN	PRUDENCE
USE CASTER LOCK DURING LOADING AND UNLOADING	USE EL FRENO DE LA RUEDA CUANDO SE CARGUE Y DESCARGUE	UTILISER LES FREINS DE ROULETTES LORS DU CHARGEMENT OU DU DÉCHARGEMENT