

BM3 SERIES

MECHANICAL DOCK LEVELER

OWNER'S MANUAL

INSTALLATION • OPERATION
SERVICE • REPAIR PARTS

BEACON[®] 
BEACON INDUSTRIES, INC.

12300 Old Tesson Rd. St. Louis, MO 63128-2247 USA

OFFICE: 314-487-7600 FAX: 314-487-0100

www.beacontechonology.com

E-Mail: sales@beacontechonology.com

SECTION 1

INSTALLATION INSTRUCTIONS RECEIVING AND HANDLING

RECEIVING:

Check for possible damage or missing parts immediately upon receipt of unit. Note any damage on receiving papers.

Prepare any claims against carrier if necessary.

NOTE: Damage noticed after receipt must be reported to carrier within 15 days.

Notify **Beacon** of any damage or missing parts. Failure to do so within 15 days may result in loss of warranty coverage.

HANDLING:

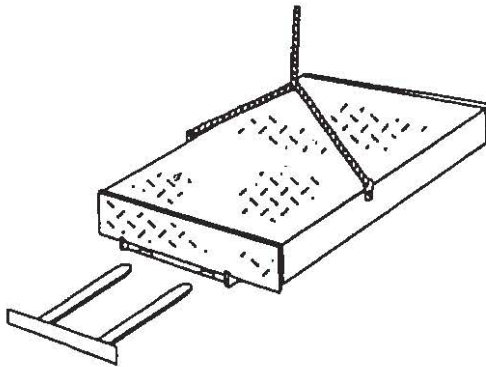

FIGURE A

Move leveler into position by using:

- chain sling inserted into upper side plate holes. (See Figure A) or
- fork lift, inserted into front fork slots;
- fork lift, inserted into rear fork slots just below the deck.

NOTE:

Two bumpers, and weather seals, if applicable, are strapped under leveler. Handle with care to avoid damage to these components. Contact for chain sling assembly (Part #1700)

SECTION 1

INSTALLATION INSTRUCTIONS INSTALLATION

INSTALLATION: (Consists of 3 phases)

Pit preparation

Leveler Preparation

Leveler Installation

FIGURE B - PLAN VIEW

BM-3 SERIES PIT DETAIL

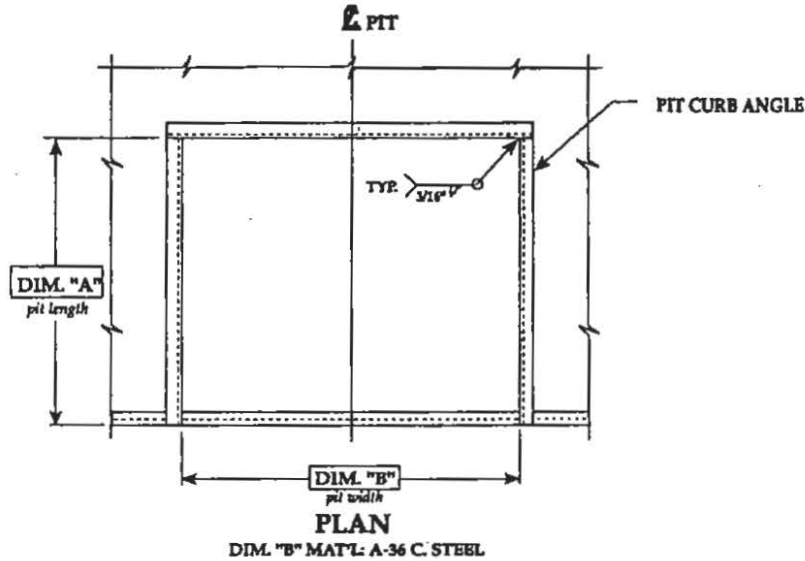

VARIABLE DIMENSIONS				
MODEL SIZE	"A"	"B"	"C"	"D"
6'W x 6'L	63"	74"	19½"	20"
6'W x 8'L	87"	74"	19½"	20"
6'-6"W x 6'L	63"	80"	19½"	20"
6'-6"W x 8'L	87"	80"	19½"	20"
7'W x 6'L	63"	85"	19½"	20"
7'W x 8'L	87"	85"	19½"	20"
6'W x 10'L	111"	74"	23½"	24"
6'-6"W x 10'L	111"	80"	23½"	24"
7'W x 10'L	111"	85"	23½"	24"

INSERT SPECIFIC JOB DIMENSIONS FROM CHART

--	--	--	--

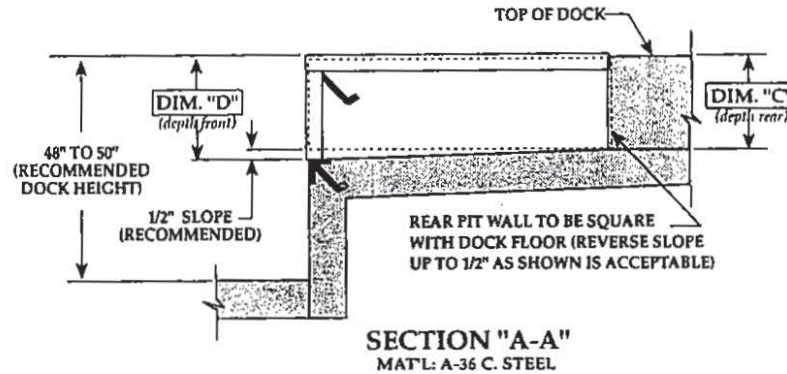
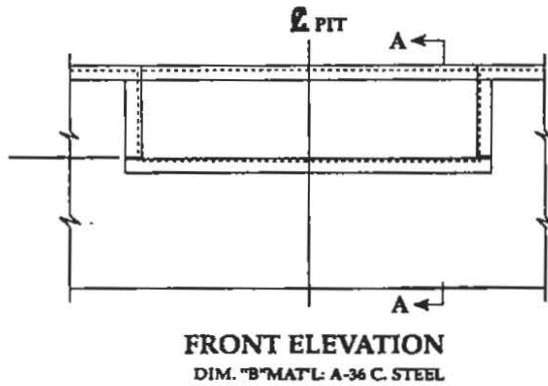

NOT TO SCALE

NOTES

JOB

DRAWN: D.E.A.	SCALE: AS NOTED	DATE: 9/30/94	DRAWING NUMBER: PMI-2012-R1
------------------	--------------------	------------------	--------------------------------

TOLERANCES:		
Inch Dimension =	Decimal Dimension =	Angles =
± 1/16"	± .005	± 1°

SECTION 1

INSTALLATION INSTRUCTIONS PIT PREPARATION

PIT PREPARATION

1. Examine pit
2. Measure pit dimensions. (See "Variable Dimensions" Figure B, Page 1-2)

Pit walls should be square and plumb. Clean all debris from pit.

Verify that walls are square and plumb.

PRE-PLACEMENT OF SHIMS:

1. Place shims in correct locations on pit floor before lowering leveler into place in pit.

Proper shim thickness will assure that deck of leveler is level with dock floor.

NOTE 1: Shims are to be placed directly under each rear frame upright, and under lip keepers. (See Figure C, Page 1-3) and (See Plan View, Page 1-2).

NOTE 2: For units with a 20" lip the lip keepers are separate. Prior to shimming, weld the angle with the lip keeper under the front base frame. (See Figure C, Page 1-3) (See Figure E, Page 1-4)

SECTION 1

INSTALLATION INSTRUCTIONS LEVELER PREPARATION

LEVELER PREPARATION

1. Position leveler directly in front of pit
2. Cut restraining band on lip.

Remove band completely from leveler..

FIGURE C

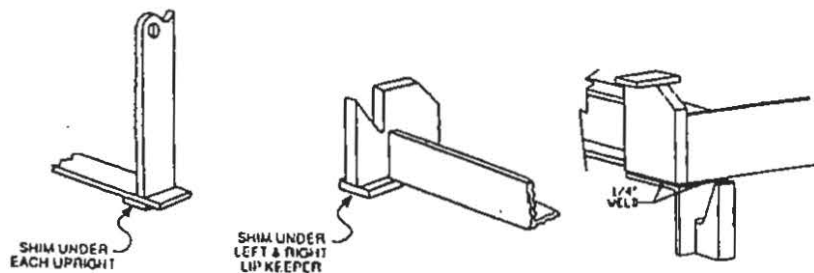
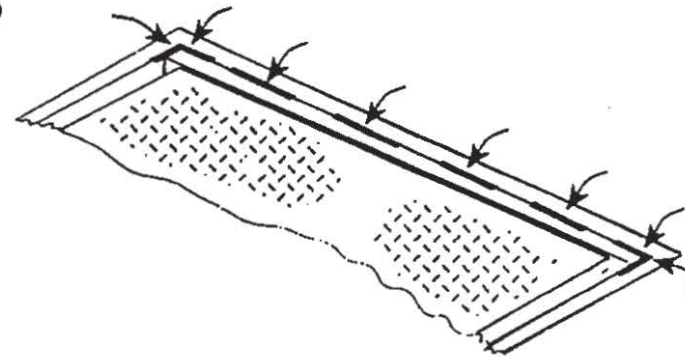

FIGURE D



SECTION 1**INSTALLATION INSTRUCTIONS
LEVELER INSTALLATION**

LEVELER INSTALLATION:

1. Place leveler into pit opening.

Allow one inch (1") equal clearance between leveler sides and pit walls. Rear frame angle of leveler should be tight against and flush with rear curb angle for proper welding.

2. Recheck shim packs to ensure leveler is at proper height, flush with floor level, front and rear, after restraining band has been cut.

For leveler with a 20" lip — with leveler flush with dock floor locate lip keepers on frame / embedded curb angle and move upwards until lip touches bottom of keeper. Lip keeper should be located 12" toward center from each side.

Shims must be placed properly under each rear frame upright, and front lip keepers. (See Figure C, Page 1-3, for close up view and Plan View B, Page 1-2, for shim locations.)

Skip weld rear of leveler to curb angle (weld center first then ends) and front shims to leveler and curb angle. (See Figure D, Page 1-3)

3. Bring deck section of leveler to fully raised position.

To operate, pull and hold the ratchet release chain located at rear of leveler.

4. Place maintenance strut securely under leveler.

Place strut in tubes located on base & under lip.

5. Weld all shims securely in place.

Front shims must be welded securely to frame and steel curb angle.

6. Store maintenance strut.

Walk forward onto leveler, returning it to dock level with lip in keepers.

7. Install bumpers on dock face.

Securely bolt bumpers to dock face as close to pit opening as possible. Bumpers should be flush with dock floor or 48" off ground. Raised bumpers should be supported to floor from behind.

8. Complete weld at rear of leveler.

Weld to cover approximately 50% of the length of the rear angle. Ensure welds are placed directly behind frame uprights and at ends of angle. (See Figure D, Page 1-3)

20" LIP KEEPER INSTALLATION INSTRUCTIONS

Two separate lip keeper angles are provided with every unit that has a 20" lip. These angles are tack welded to the leveler base frame just behind the lip.

Break each one loose and set the leveler into the pit per the installation instructions in the owner's manual.

Prior to angle installation or shimming make sure that the unit is snug against the embedded curb angle at the back of the pit.

Place the lip keepers under the front base angle on either side of the unit with the top of the angle protruding out past the base 1/4" in the front and on the left for the left hand keeper and on the right for the right hand keeper. This will facilitate welding.

Fully weld the keeper angle to the base angle.

Proceed with shimming per the owner's manual.

TOP VIEW

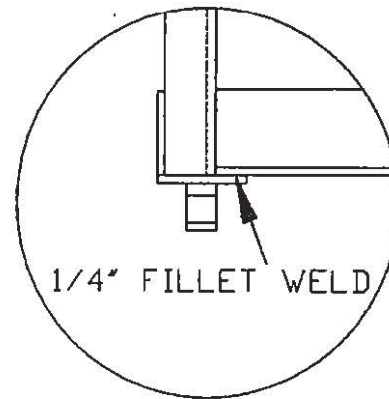

PICTORIAL VIEW

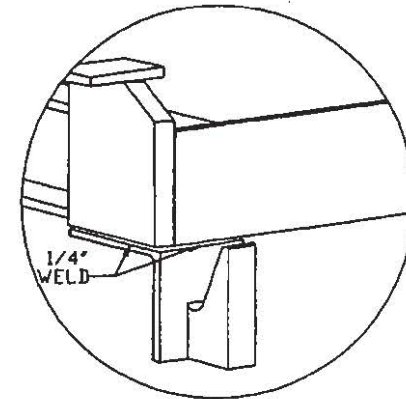

FRONT VIEW

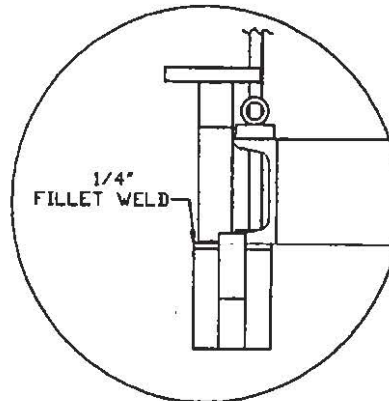

SIDE VIEW

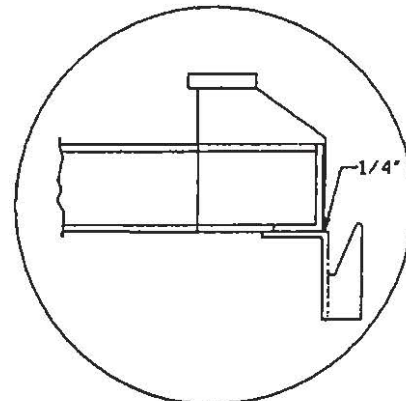

SECTION 2**OPERATING INSTRUCTIONS
ABOVE DOCK OPERATION****ABOVE DOCK USE:**

- | | |
|--|--|
| 1. Pull firmly and hold the release ring located in rear of deck. | When deck raises and lip extends, release the ring. DO NOT release the ring until the lip is fully extended. |
| 2. Walk forward onto deck to lower unit onto truck bed. (Truck should be secured firmly against bumpers with "Truck Restraint" or wheel chocks.) | With standard locking type lip mechanism, lock will release once lip makes firm contact with truck bed. |
| 3. When truck departs, lip will close to pendant (not stored) position. | This action applies when truck is above dock height. |
| 4. Walk forward onto deck until unit is returned to stored position. | In this position, lip is secure in lip keepers, and ready to receive the next truck. |
| 5. Leveler may be recycled with truck at dock. | Pull the rear release ring in short, rapid pulls allowing deck to raise 2" – 3" above dock with lip down. This allows operator to close the truck and/or building door prior to truck departure.

Walk forward onto leveler, returning it to dock level with lip in keepers. |

SECTION 2**OPERATING INSTRUCTIONS
BELOW DOCK OPERATION****BELOW DOCK USE: (WITH LIP EXTENDED)**

1. Repeat steps 1 & 2 for above dock use.	
2. As you walk forward on the leveler, pull the safety leg release ring located in the front of deck plate.	This will pull safety legs away from the pads they would normally contact allowing unit to go below dock. When lip makes firm contact with the truck bed, release the front ring.
3. When truck departs, lip will return to pendant (not stored) position.	Lip will be in front of lip keepers, and deck will remain below floor level.
4. To recycle unit after truck departure, pull release ring in short, rapid pulls.	This action will allow the deck to raise 2" – 3" above dock floor while the lip will remain in a pendant position.
5. Leveler may be recycled with truck at dock .	Follow Step #4 to recycle.
6. Following Step #4, walk forward onto deck until unit is returned to stored position.	Lip should be completely closed and resting in lip keepers which provide overnight security.

SECTION 2**OPERATING INSTRUCTIONS
BELOW DOCK OPERATION****BELOW DOCK USE: (LIP RETRACTED FOR END LOADS)**

BELOW DOCK CONTROL OPTION IS RECOMMENDED FOR THIS OPERATION:

1. Pull release ring in short rapid pulls.

Allow deck to raise 2" – 3" above dock floor. (This will raise lip out of lip keepers, without extending lip.)

2. As you walk forward on the leveler, pull the safety leg release ring located in the front of deck plate.

With Below Dock Control option, lip will be pushed out in front of keepers while safety legs are being pulled away from pads.

3. When truck departs, lip will close to pendant (not stored) position.

Lip will be in front of keepers, and deck will remain below dock.

4. To recycle unit after truck departs, pull release ring in short, rapid pulls.

Continue this until unit is 2" – 3" above dock floor.

5. Leveler may be recycled with truck at dock.

Follow Step #4 to recycle.

6. Following Step #4, walk forward onto deck until unit is returned to stored position.

Lip should be completely closed and resting in lip keepers which also provide overnight security.

LEVELERS ARE TESTED AND ADJUSTED AT THE FACTORY. HOWEVER, MINOR ADJUSTMENTS TO THE MAIN SPRINGS MAY BE REQUIRED ONCE THE UNIT IS INSTALLED. (UNITS WITH WEATHER SEALS NORMALLY REQUIRE MAIN SPRING ADJUSTMENT TO INSURE PROPER LIP EXTENSION.

NOTE: ALWAYS SECURE LEVELER WITH MAINTENANCE STRUT BEFORE SERVICING.

SYMPTOM:	PROBABLE CAUSE:	CORRECTION:
<p>WHEN RELEASE RING IS PULLED, DECK RAISES BUT LIP DOES NOT FULLY EXTEND AND LOCK.</p> <p>Note: With Hydra-Lip Option, lip is designed to begin closing once extended, or when truck departs. No adjustment is required. Assem. #30</p>	<p>1. Improper main spring adjustment. NOTE: On units with either lip assist or hydra lip, proper adjustment will entail a combination of adjusting the lip assist spring and possibly the main springs. (See #3 below)</p>	<p>Tighten both main spring adjustment nuts one or two rotation clockwise and re-test. Item #7 (1 1/2" socket or wrench)</p>
	<p>2. Lip lock spring is stretched.</p>	<p>Replace spring or lower spring one or two links in snubber chain. Item #22; Assem. #6</p>
	<p>3. Improper adjustment of lip assist spring (furnished as standard equipment with 18" and 20" lip lengths)</p>	<p>Tighten both hex nuts, on the lip assist rods, two (2) clockwise rotations and re-test. Item # 27. Note: The back nut, toward the rear of the leverler, is the adjustment nut. After attaining proper adjustment, hold the back nut and securely tighten the front or lock nut against the adjustment nut.</p>
	<p>4. Lip lock spring is broken or disconnected.</p>	<p>Replace broken spring and/or reconnect spring to proper chain link with "S" hook. Item #22, Assem. #6</p>
	<p>Leveler may be servicing trucks that are above the factory set service range (8' models - 12", 6' models - 8") causing lip to impact truck during upward movement.</p>	<p>Minor adjustments to service range above dock may be made in the field. Consult the local PIONEER representative or call the factory for assistance.</p>

SECTION 3**TROUBLESHOOTING**

SYMPTOM:	PROBABLE CAUSE:	CORRECTION:
(HYDRA-LIP OPTION) Lip will not close completely when truck departs.	Lip assist spring is over compressed.	Loosen both hex nuts on the lip assist rod two (2) rotations <u>counter-clockwise</u> and re-test. Item # 27
(HYDRA-LIP OPTION) Lip closes too fast when extended.	Lip assist spring is under compressed.	Tighten both hex nuts on the lip assist rod two (2) clockwise rotations and re-test. Item # 27
	Shocks are failing after years of use.	Replace with new shocks. Item # 29 (Covered by 1 year warranty)

BM3 Series

PARTS LIST	
ITEM	DESCRIPTION
1	LIP PLATE ASSEMBLY 16"
2	HINGE PIN-LIP
4	MAIN SPRING
5	RATCHET PULL CHAIN ASSEMBLY
18	RATCHET MOUNTING ASSEMBLY UPPER
23	SAFETY LEG & MOUNTING ASSEMBLY
24	SAFETY LEG CHAIN ASSEMBLY
25	LIP LOCK ASSEMBLY
26	ROLL PINS
27	LIP ASSIST ASSEM. (STANDARD ON 18" & 20" LIP)

OPTIONAL KITS (FIELD INSTALLED)	
ITEM	DESCRIPTION
27	LIPP ASSIST ASSEM. (OPTIONAL ON 16" LIP)
29	SHOCK ABSORBER
30	HYDRA LIP KIT
31	FULL RANGE TOES GUARDS (SET)
	WEATHER SEAL KIT 6'
	WEATHER SEAL KIT 8'

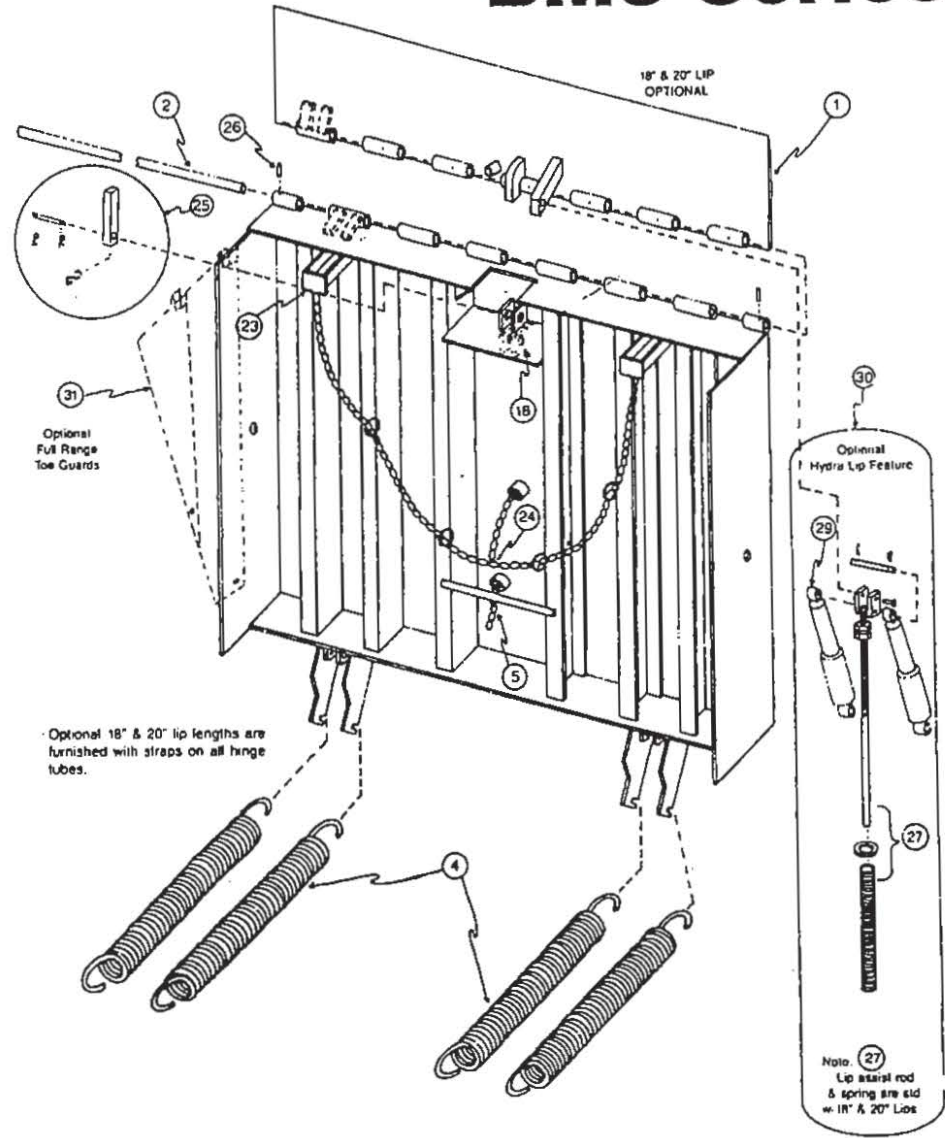

PARTS LIST

ITEM	DESCRIPTION
3	DECK REAR HINGE KIT (SET)
6	SNUBBER CHAIN ASSEMBLY (For standard 16" Lip)
7	ADJUSTING ROD ASSEMBLY
8	WING NUT ASSEMBLY
9	RATCHET ASSEMBLY
10	UPPER BAR
11	PAWL
12	PAWL SPRING
13	RELEASE LEVER SPRING
14	RATCHET HOUSING
15	UPPER PIN KIT
16	LOWER PIN KIT
19	RATCHET MOUNTING ASSEMBLY LOWER
20	SNUBBER SPRING
21	SNUBBER CHAIN TENSION SPRING
22	LIP LOCK SPRING
28	"S" HOOK
32	AUXILIARY RACHET RELEASE CHAIN

