

OWNER'S MANUAL

HYDRAULIC SKID TRUCK • MODEL BHIPM

Contents

Warnings and Safety Instructions	1	Exploded Parts Drawing	10
Receiving Instructions	1	Parts Identification	11
Loading Instructions	2	Periodic Maintenance Instructions	12
Operating Instructions	2	Foot Pump Operation	13
Electric Schematic	3	Warning Label Identification	14
Battery Charger Operation	4-5	Material Safety Data Sheets.....	15-18
Hydraulic Operation and Schematic.....	6-7	Warranty	19
Trouble Shooting Guide	8-9	Ergonomic Solutions.....	20

WARNINGS & SAFETY INSTRUCTIONS

Read owner's manual completely before operating unit!

- Not a personnel lift.
- Never go under forks if there is weight on unit.
- Remove weight & disconnect power before working on unit.
- Use only maintenance parts supplied or approved by the manufacturer.
- Do not change pressure relief valve setting.
- Do not clamp hydraulic cylinder in a vise as you may distort the barrel.
- Never operate the lift unless you are watching it.
- Do not go near leaks - High pressure oil easily punctures skin causing serious injury, gangrene, or death.
- Load tight against the bulkhead within the rated capacity.
- Transport loads in the lowered position only.
- Do not continue to operate the UP control if unit is not raising.
- Relieve system pressure by operating the DOWN control after the unit has come to rest.
- Consult factory before adding or performing any modification to the original equipment.
- Do not use brake fluids or jack oils. Use AW-32 Hydraulic oil or equal.
- Make sure all operator safety labels and guards are in place.

damage during transit. If you see damage when unloading make a note of it on the SHIPPER RECEIVER.

Remove all packing and strapping material, inspect for damage. **IF DAMAGE IS EVIDENT, FILE A CLAIM WITH THE CARRIER IMMEDIATELY!** Also, check the unit size, type of power unit, etc., to ensure the unit is correct for the intended application.

SERIAL NUMBER AND CAPACITY

The serial number and capacity is inscribed on the nameplate (*See p. 14 for location*). Please remember to include these numbers in any correspondence with your dealer or the factory.

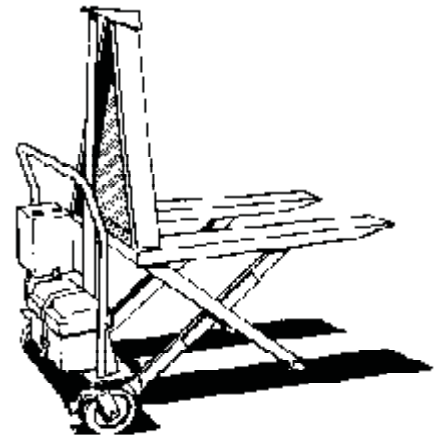

**HYDRAULIC SKID TRUCK
MODEL BHIPM**

RECEIVING INSTRUCTIONS

Every unit is thoroughly tested and inspected prior to shipment. However, it is possible that the unit may incur

LOADING INSTRUCTIONS

The load capacity rating as inscribed on the nameplate of your unit designates the net capacity for an evenly distributed load. This capacity must never be exceeded, as permanent damage or injury may result.

When loading the lift always follow these guidelines:

- 1.) Always load tightly against the bulkhead.
- 2.) Transport loads in the lowered position only.

OPERATING INSTRUCTIONS

The *High Rise Lift* is furnished with a constant pressure rocker switch control as standard equipment.

In order to operate the unit, pressure must be maintained in the **UP** or **Down** position to raise or lower the forks. On releasing either button, the forks will remain in that particular position until the switch is depressed again.

Responsibilities of Owners/Users

It is the responsibility of the owner/user for the following:

- 1.) The lift must be inspected and maintained in accordance with the guidelines in this manual.
- 2.) Any lift not in safe operating condition must be removed from service until it is returned to proper operating condition.

Unsafe condition may include, but is not limited to the following : excessive hydraulic or air leakage, missing rollers, pins, or fasteners, any cracked or deformed structural members, cut or frayed hydraulic, electric or air lines, and damaged controls or safety devices.

All repairs and maintenance must be performed by qualified personnel.

- 3.) Lift may only be used by authorized personnel. All lift operators must have read and understood all operating procedures and safety guidelines in this Owner's Manual.
- 4.) Lift must never be overloaded.
- 5.) Operator must ensure that all safety features of the lift are functioning properly before each use.
- 6.) Any modifications to the lift must be approved in writing by the manufacturer.

ORDERING REPLACEMENT OR EXTRA PARTS

Our company takes pride in using the finest available parts for our equipment. We are not responsible for equipment failure resulting from the use of unapproved replacement parts. To order replacement or extra parts for your equipment contact Customer Service at the factory. In any correspondence with the factory please include the **Serial Number** which is inscribed on the nameplate of the piece of equipment. Use only the part numbers provided in this Owner's Manual. When ordering parts for AC power units please indicate the motor phase and voltage that the equipment is operating on.

ELECTRICAL SCHEMATIC

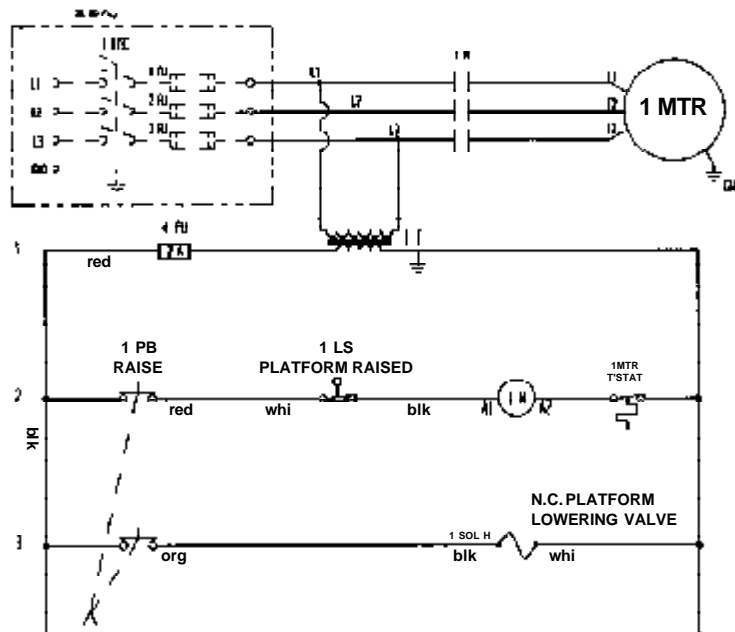
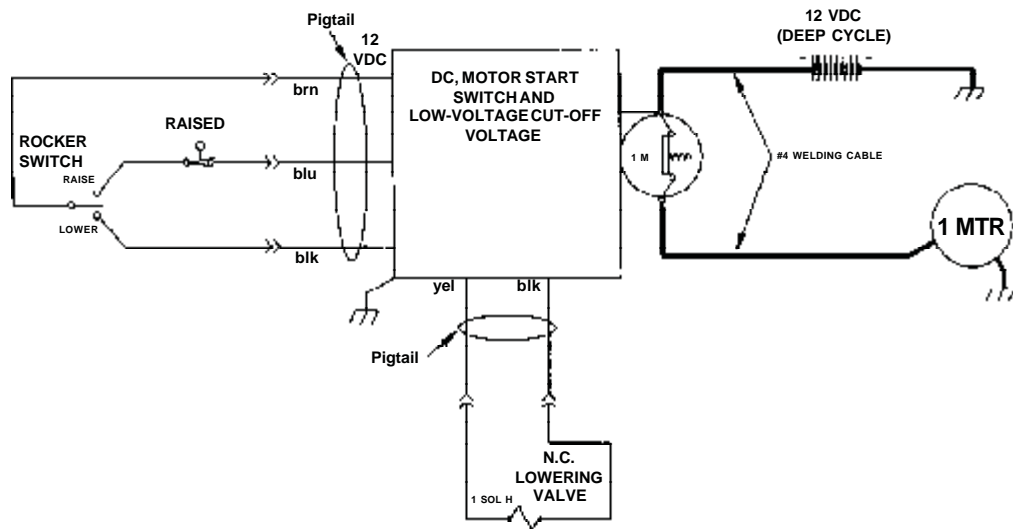

BE SURE ALL POWER IS OFF BEFORE ATTEMPTING TO WORK ON THIS EQUIPMENT!
 CAUTION: SERVICE WORK SHOULD BE PERFORMED ONLY BY TRAINED & QUALIFIED PERSONNEL

Operating Instructions for Optional Bench Top Style Battery Charger

(for DC models equipped with our Bench Top Charger)

WARNING!

Working with or near lead acid batteries is dangerous. Batteries contain sulfuric acid and produce explosive gases. A battery explosion could result in loss of eyesight or serious burns.

Do not smoke or allow a spark or flame near batteries. Charge batteries in locations which are clean, dry, and well ventilated. Do not lay tools or anything metallic on top of any battery. All repairs to a battery must be made by experienced and qualified personnel.

When working with batteries, remove personal items such as rings, bracelets, necklaces, and watches. A battery can produce enough voltage to weld jewelry to metal causing a severe burn.

Always have plenty of fresh water and soap nearby in case battery acid contacts skin, clothing, or eyes.

Operating the battery with a low battery voltage can cause premature motor contact failure.

OPERATING INSTRUCTIONS

Even if you did not purchase an optional battery charger, your new *High Rise Lift Truck* has been fitted with a matching plug which will connect directly to the *Bench Top Charger* we offer. Contact your distributor if you wish to purchase a battery charger.

Do's and Don'ts

DO NOT leave charger connected for an indefinite length of time.

DO NOT smoke, strike a match or cause a spark in the vicinity of battery during charging.

DO make sure all battery connections are tight and clean.

DO NOT expose to rain or adverse conditions.

DO replace defective cords and wires immediately.

DO locate charger at least 24" above floor while charging.

DO NOT overcharge battery (*manual* position only)

Operating Instructions for Standard On Board Style Battery Charger

(for DC models equipped with our On Board Charger)

WARNING!

Working with or near lead acid batteries is dangerous. Batteries contain sulfuric acid and produce explosive gases. A battery explosion could result in loss of eyesight or serious burns.

Do not smoke or allow a spark or flame near batteries. Charge batteries in locations which are clean, dry, and well ventilated. Do not lay tools or anything metallic on top of any battery. All repairs to a battery must be made by experienced and qualified personnel.

When working with batteries, remove personal items such as rings, bracelets, necklaces, and watches. A battery can produce enough voltage to weld jewelry to metal causing a severe burn.

Always have plenty of fresh water and soap nearby in case battery acid contacts skin, clothing, or eyes.

Operating the battery with a low battery voltage can cause premature motor contact failure.

Our *On Board* charger is equipped with an external ground wire (small green). During installation the charger must be grounded to the equipment which it is connected to. Be sure this wire is always connected to the chassis, frame, or other metallic surface considered to be ground.

OPERATING INSTRUCTIONS

- 1.) Plug charger into a receptacle known to have approximately 115V and 60 Hz. If an extension cord must be used, keep it short and as large as possible. A small cord will decrease the output of the charger due to the voltage drop in the line. This will increase the charging time.
- 2.) When properly connected, the charge LED will indicate the status of charge current flowing to the battery.
- 3.) With only the red LED lit, the charger is providing full output to the battery.
With both the red and green LED's lit the charger is "topping off" the battery.
When only the green LED is on, the unit is providing a "float" or maintenance, charge.
- 4.) Remember to unplug the charger before moving equipment. Failure to do so could cause damage to cords, receptacles and other equipment.

ADDITIONAL INFORMATION

The *On Board* charger is current limited and will not exceed its rated output, even if loads are placed on the battery while the battery is charging.

The *On Board* chargers fuse will blow if the charger is connected in reverse polarity

TROUBLESHOOTING

- 1) Make sure battery connections are electrically and mechanically sound.
- 2) Check AC source for power.
- 3) Check fuse. Replace only with a fuse having the same rating as originally supplied.
- 4.) Check battery condition. A highly sulfated battery may take some time before current begins to flow through it.

DO'S AND DON'TS

DO NOT leave charger connected for an indefinite length of time.

DO NOT smoke, strike a match or cause a spark in the vicinity of battery during charging.

DO make sure all battery connections are tight and clean.

DO NOT expose to rain or adverse conditions.

DO replace defective cords and wires immediately.

HYDRAULIC OPERATION FOR AC/DE

When the operator wants to raise the unit, he/she depresses the **UP** button. This starts the electric motor which turns the hydraulic pump. Oil from the reservoir is drawn in through the suction filter and into the pump.

The pump delivers pressurized oil through a check valve before it enters the cylinders.

The function of the check valve is to allow the oil to flow in one direction, (towards the cylinders), and prevents the flow of oil back into the pump circuit when the pump stops running. This holds the oil in the cylinders and will maintain any particular barrel elevation, for extended periods of time.

If the load is excessive, and the **UP** button is still depressed, excessive pressure will build up in the circuit between the pump and the cylinders. This forces the relief valve to unseat allowing the pump flow to circulate to the reservoir preventing hydraulic or structural damage.

When the operator desires to lower the unit, he/she depresses the **DOWN** button. This energizes the lowering solenoid valve coil, unseating the poppet valve and allowing oil return from the cylinders through the pressure-compensated flow control valve, to the reservoir.

Releasing the **DOWN** button will de-energize the solenoid, closing the valve poppet. This and the check valve prevents the oil from returning to the reservoir and the cylinders will stop retracting. The unit will maintain that particular elevation until the operator chooses to move it once again.

Cartridge Valves

The lowering valve, as discussed above, is of cartridge construction and is virtually maintenance-free. If there is a faulty operation, check Trouble Shooting Section. To clean the cartridge valve, follow this procedure:

- 1.) **WARNING!** Lower forks completely before removing cartridge valve.
- 2.) Use a sharp object to push poppet in from the bottom to open the valve.
- 3.) Repeat several times while valve is immersed in kerosene or mineral spirits. Blow dry.
- 4.) Blow compressed air through valve while holding the valve open as described in step 2.
- 5.) Inspect "o" rings and the teflon washer. If either shows nicks, tears, or cuts, replace.
- 6.) Reinstall. The valve should be tightened to approximately 20 ft. lbs.

Velocity Fuse

There is a brass velocity fuse with a stainless steel spring in the base of each cylinder (Item 10). In the event of a hydraulic hose or fitting failure, the platform starts to lower at a fast rate. As soon as the descent speed exceeds the preset speed, the Velocity Fuse will shut off the oil flow and the platform will remain nearly stationary until pressure is re-applied after repairs are done. This safety feature reduces the possibility of accidental personal injury or damage to the table or contents. If air is introduced into the system, the velocity fuse can lock up even though no failure has occurred. To reset the velocity fuse just activate the pump by jogging the **UP** button. Remove the load and cycle the unit several times to purge air.

Air Bleed Procedure

If the forks descend very slowly or will not descend at all, air is likely trapped in the hydraulic circuit and must be bled from the system. The High Rise Lift Truck utilizes a bleeder screw at the top of the cylinder. To bleed air from the hydraulic circuit, follow these directions.

- 1.) Loosen the bleeder screw at the top of the cylinder approximately 1/4 to 1/2 turn to allow trapped air to escape. Depress the foot pump treadle or job the motor to push the out of the system.
- 2.) When the cylinder is free of air only clear hydraulic fluid will be visible at the bleeder screw. Tighten the hose fitting.

HYDRAULIC SCHEMATIC

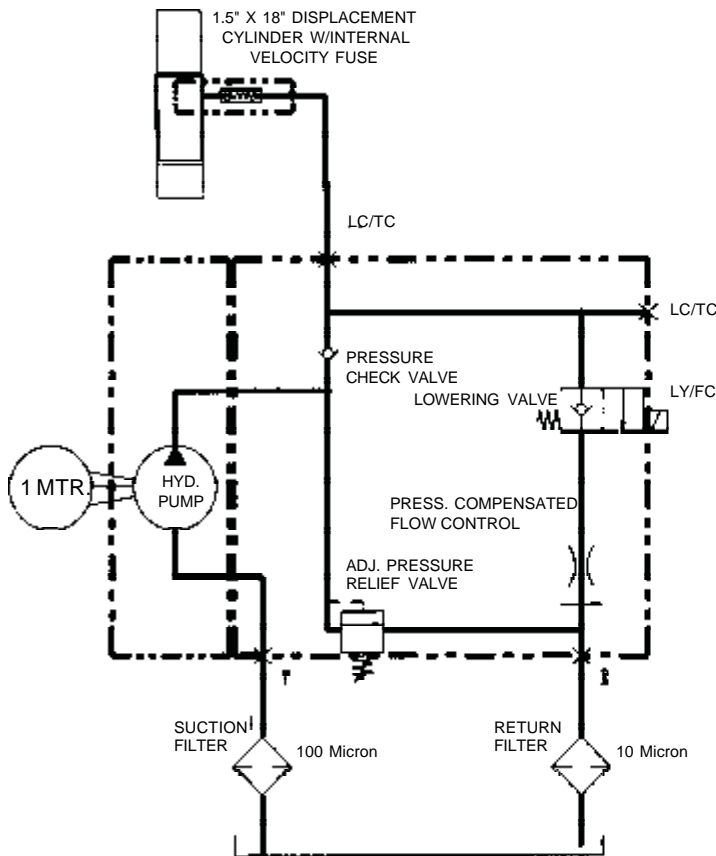

**ELECTRIC POWER UNIT
HYDRAULIC DIAGRAM**

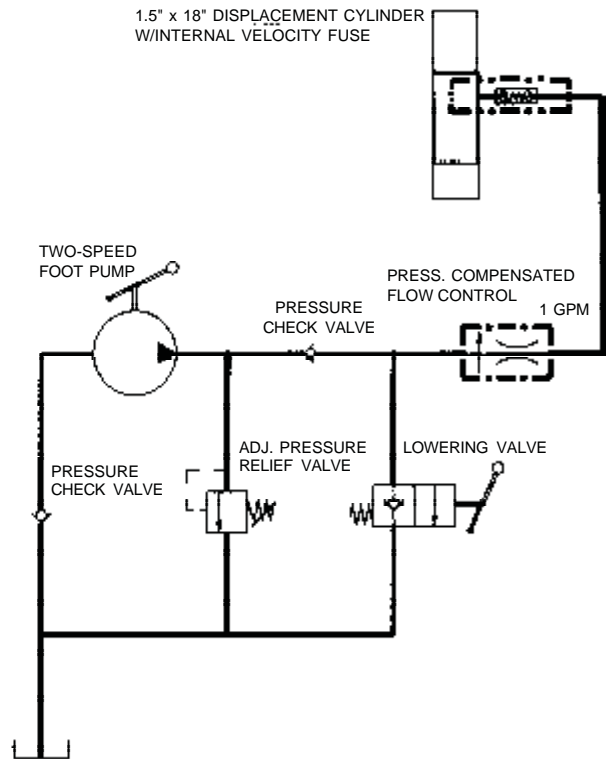

**MANUAL FOOT PUMP
HYDRAULIC DIAGRAM**

HYDRAULIC EQUIPMENT

Trouble Shooting Quick Reference Guide (For further information contact the factory)

Observation	Possible Cause	Remedy
1.) Forks do not raise but pump is running or humming.	a. Voltage at motor terminals may be too low to run pump at existing load.	a. Measure voltage at motor terminals or as near as possible, while pump is running under load. If voltage is sufficient, check for inadequate or incorrect wiring as this can starve the motor. (Refer to chart in Owner's Manual for recommendations.) Correct as necessary.
	b. Hose or hydraulic line is leaking.	b. Correct as necessary.
	c. Fluid level in reservoir is low.	c. Add fluid. Refer to Owner's Manual for proper fluid levels.
	d. Load exceeds capacity requirements. Relief Valve is bypassing the fluid back into the reservoir.	d. DO NOT CHANGE RELIEF VALVE SETTING. Instead, reduce the load to rated capacity.
	e. Suction filter is clogged, starving pump.	e. Remove and clean.
	f. Suction line may be leaking air, due to loose fittings.	f. Inspect all fittings for proper fit.
	g. Filler/Breather cap on tank may be clogged.	g. Remove and clean.
	h. Down Valve may be energized by faulty wiring or stuck open.	h. Remove Solenoid Valve. Check and clean (Refer to Hydraulic Section of Owner's Manual p.6).
	i. Hydraulic pump may be inoperative.	i. Disconnect hydraulic line at power unit. Put pressure line in a large container and cycle pump. If no output, check the pump motor coupling, which may be defective, and correct as necessary. If pump is worn, consult factory for replacement parts service.
	j. Low battery (DC units only).	j. Adequately charge battery before further operation. (Refer to Charging Section of Owner's Manual.)
2.) Forks raise too slowly.	a. Foreign material stuck in Down Solenoid, causing some fluid to bypass back into tank.	a. Lower the forks. Remove the Solenoid Valve and clean (Refer to Hydraulic Section of Owner's Manual p.6).
	b. Foreign material clogging suction filter, breather cap, or a pinched hose.	b. Correct as necessary. (See also, 1(f), (h)).
	c. Low motor voltage.	c. See 1(a).
	d. Table overloaded.	d. See 1(e).
	e. Pump is inoperative.	e. See 1(j).
	f. Low battery (DC units only).	f. Charge battery.
3.) Motor labors, or is excessively hot.	a. Voltage may be low.	a. See 1(a).
	b. Incorrect wiring.	b. Check that one leg of the motor lines is not connected to ground.
	c. Oil starvation causes pump to bind. High internal heat is developed. If this occurs, pump may be permanently damaged.	c. See 1(d), (f), (g), (h), (j).
	d. Binding cylinders.	d. Align cylinders correctly.
	e. Low battery (DC units only).	e. Charge battery.

Observation	Possible Cause	Remedy
4.) "Spongy" or "Jerky" table operation. Do not confuse spongy operation with small surges caused by foreign material on table wheel roller plate.	<ul style="list-style-type: none"> a. Fluid starvation. b. Air is trapped in cylinder. 	<ul style="list-style-type: none"> a. See 1(d), (f), (g), (j). b. See air bleed procedure on p.7.
5.) Forks lower too slowly when loaded.	<ul style="list-style-type: none"> a. Down Valve filter clogged. b. Pinched tube or hose. c. Foreign material in Flow Control Valve. d. Binding cylinders e. Foreign material in Velocity Fuse. 	<ul style="list-style-type: none"> a. Remove Solenoid Valve and clean filter. b. Correct as necessary. c. Remove and clean Flow Control Valve. (Refer to Hydraulic Section of Owner's Manual p. 6). d. Align cylinders correctly. e. Remove and clean Velocity Fuse. (Refer to Hydraulic Section of Owner's Manual p. 6).
6.) Forks lower too quickly.	<ul style="list-style-type: none"> a. Leaking hoses and/or cracked fittings. b. Check valve is stuck open. c. Foreign material stuck in Flow Control Valve. 	<ul style="list-style-type: none"> a. Correct as necessary. b. Remove and clean Check Valve. (Refer to Hydraulic Section of Owner's Manual p. 6). c. Remove Flow Control Valve from the Valve Block and clean. (Refer to Hydraulic Section of Owner's Manual p. 6).
7.) Forks raise then lower slowly.	<ul style="list-style-type: none"> a. Down Solenoid Valve may be incorrectly wired or is stuck open due to dirt. b. Check Valve may be stuck open. c. Check for leaking hoses, fittings, pipes. d. Cylinder packings may be worn or damaged. 	<ul style="list-style-type: none"> a. See 2(a). b. Remove and clean Check Valve. (Refer to Hydraulic Section of Owner's Manual.) c. Correct as necessary. d. Replace packings.
8.) Forks raise, but do not lower.	<ul style="list-style-type: none"> a. Incorrect Down Solenoid Valve wiring. b. Down Solenoid Valve is stuck. c. Faulty Down Solenoid Coil. d. Object blocking down travel. e. Binding cylinders. f. In case of excessive down speeds, the Velocity Fuse will become operative and shut off the oil flow from the cylinders, thus the platform will remain stationary. g. Check if the Limit Switch is inoperative and the platform has raised all the way so that the mechanical stops are engaged. If mechanical stops are engaged, the Velocity Fuse has been locked up. 	<ul style="list-style-type: none"> a. Correct as necessary. (Refer to Electrical Section of Owner's Manual.) b. Lightly tap down the Solenoid Coil body to seat it properly. (DO NOT hit coil hard as it will permanently damage the internal stem). DO NOT remove the Solenoid Valve from the Block as the unit will come down at a dangerous speed. c. Remove and replace. (Refer to Electrical Section of Owner's Manual.) d. Raise forks and remove the object blocking the down travel, then press the down button. e. See 2(e). f. To unlock, re-pressurize the hydraulic system. g. Refer to Velocity Fuse Section of the Owner's Manual.
9.) Erratic or uncontrolled operation.	<ul style="list-style-type: none"> a. Low battery (DC units only). 	<ul style="list-style-type: none"> a. Charge battery.

**EXPLODED PARTS DRAWING
HYDRAULIC SKID TRUCK
Model BHIPM**

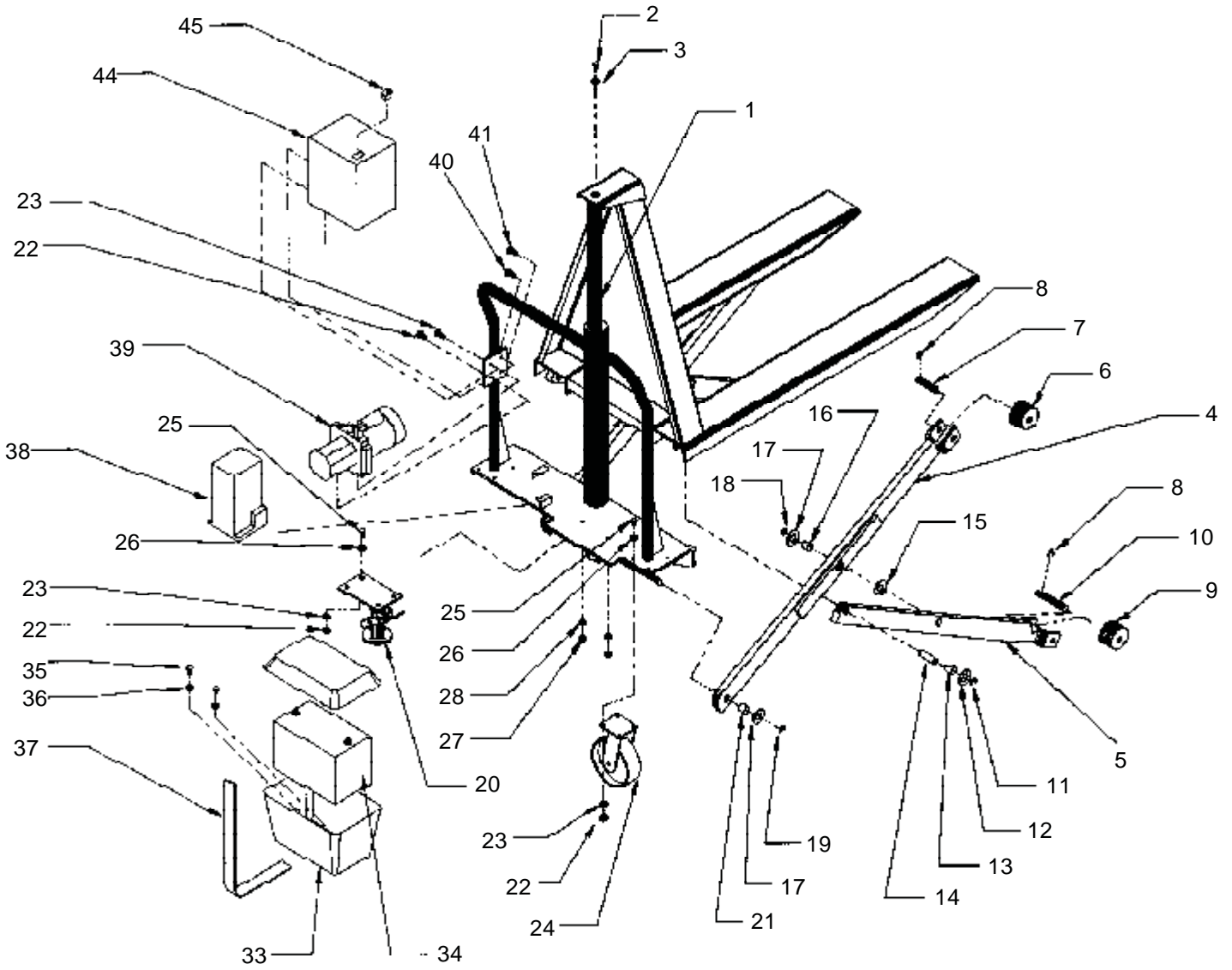

PARTS IDENTIFICATION - HYDRAULIC SKID TRUCK • Model BHIPM

KIT NO.	ITEM NO.	DESCRIPTION	ENGINEER NO.	PART NO.	QTY.
	1	Hydraulic cylinder (1-½ x 28)	B15-021-006	BHIPM-CYL	1
	2	3/8" x 1" hex head cap screw	n/a	n/a	1
	3	3/8" split lock washer	n/a	n/a	1
	4	Inner leg	B15-010-005	BHIPM-INLG	2
	5	Outer leg	B15-010-006	BHIPM-OTLG	2
D	6	Inner leg roller	B16-132-001	BHIPM-ILG-RLR	4
D	7	Inner leg roller pin	B15-112-008	BHIPM-ILG-RP	4
C,D	8	3/4" clip ring	n/a	n/a	2
C	9	Outer leg roller	B16-132-001	BHIPM-OLG-RLR	4
C	10	Outer leg roller pin	B01-112-008	BHIPM-OLG-RP	2
	11	3/4" clip ring	n/a	n/a	4
	12	3/4" x 18 ga. machinery bushing - narrow rim	n/a	n/a	4
	13	Outer leg hinge bearing	B01-111-007	BHIPM-OLG-HB	2
	14	Outer leg hinge pin	B05-112-006	BHIPM-OLG-HP	2
	15	1" x 18 ga. machinery bushing - narrow rim	n/a	n/a	2
B	16	Axle pin bearing	B01-111-006	BHIPM-APB	2
	17	1" x 18 ga. machinery bushing - narrow rim	n/a	n/a	2
	18	1" clip ring	n/a	n/a	2
	19	3/4" clip ring	n/a	n/a	2
	20	Floor lock	B16-132-080	BHIPM-FLK	2
B	21	Inner leg hinge pin bearing	B01-111-007	BHIPM-ILG-BG	2
A	22	3/8-16 nylon insert lock nut	n/a	n/a	8
A	23	3/8" USS flat washer	n/a	n/a	8
A	24	Swivel caster (add a "-B" for caster with brake)	B16-132-034	BHIPM-CST-S	2
A	25	3/8-16 x 1-¼" hex head cap screw	n/a	n/a	8
A	26	3/8" USS flat washer	n/a	n/a	8
	27	5/16-18 nylon nut	n/a	n/a	2
	28	5/16" USS flat washer	n/a	n/a	2
	33	Battery box (includes lid)	B15-139-002	BHIPM-BTBX	1
	34	Battery (SHIPS VIA TRUCK ONLY)	B15-139-001	BHIPM-BT	1
	35	¼"-20 x 1-¼" slotted head screw	n/a	n/a	2
	36	¼" I.D. fender washer	n/a	n/a	2
	37	Battery box strap (included with battery)	n/a	BHIPM-BTBX-ST	1
	38	Hydraulic reservoir	B15-023-001	BHIPM-RES	1
	39	DC Motor / pump assembly	B15-137-001	BHIPM-DCPU	1
	39A	DC motor only	B01-135-041	BHIPM-MTR	1
	39B	Hydraulic pump only	B01-143-015	BHIPM-PMP	1
	39C	Motor start solenoid	B01-034-026	BHIPM-SOL	1
	39D	Cartridge valve assembly	B01-153-009	BHIPM-CVA	1
	40	3/8-16 x 1" self drill and tap screw	n/a	n/a	2
	41	3/8-16 x 1" hex head cap screw	n/a	n/a	2
	44	Power unit shroud	B15-024-006	BHIPM-PU-S	1
	45	Raise / lower control switch	B15-022-006	BHIPM-CS	1
A		Caster kit (includes items 22-26)	B15-022-006	BHIPM-KIT-A	1
B		Bearing kit (includes items 16,21)	B15-154-012	BHIPM-KIT-B	1
C		Outer roller kit (includes items 8-10)	B15-154-013	BHIPM-KIT-C	1
D		Inner roller kit (includes items 6-8)	B15-154-014	BHIPM-KIT-D	1
E		Cylinder seal repair kit (includes all seals for repair)	B15-154-015	BHIPM-KIT-E	1

a/k Available only with purchase of kit
n/a Not Available

PERIODIC MAINTENANCE INSTRUCTIONS

WARNING! REMOVE LOAD AND COMPLETELY LOWER FORKS BEFORE PERFORMING ANY MAINTENANCE.

(A) Before Each Use Check For The Following :

- 1.) Frayed wires (*Powered models only*)
- 2.) Oil leaks
- 3.) Proper caster operation
- 4.) Pinched or chafed hoses, loose fittings
- 5.) Structural deformation of forks or frame
- 6.) Unusual noise or binding

Do not use if there are any of the above!

(B) Monthly Inspections

- 1.) Check oil level. Oil should be 1" to 1-1/2" below the top of the tank with the lift in the fully lowered position. Add as necessary.
- 2.) Check for oil leaks. See Trouble Shooting Section and correct as necessary.
- 3.) Check water level in battery. (*DC models only*)
- 4.) Check clevis and pivot points for wear.
- 5.) Check for worn or damaged hydraulic hoses, electrical wires, and cords. Repair as necessary.
- 6.) Check rollers for looseness and wear. See Trouble Shooting.
- 7.) Check retaining rings at load rollers and clevis.
- 8.) Check for unusual noise. See Trouble Shooting section.
- 9.) Make sure all warning labels are in place and in good condition.
- 10.) Clean off dirt and debris.

(C) Yearly Inspection

Hydraulic oil should be changed at least once a year, or sooner if the oil darkens or becomes gritty. Flush reservoir before refilling. Presence of water is indicated if the oil turns milky. Recommended oil: Purity ISO AW-32 Hydraulic fluid or equal.

All maintenance work must be performed by qualified personnel with training in the repair of electrical and hydraulic components.

Operating Instructions for Two-speed Hydraulic Foot Pump

Features:

Your new lift equipment has been supplied with an exclusive two-speed foot pump. The internal features of your pump include a primary pressure relief valve, pressure compensated return flow control valve, and an integrated lowering valve.

Replaceable bushings, valve components, and seals have been utilized in the construction of the pump in the event that replacements are necessary.

Operating Instructions:

Stay clear of moving parts. The platform will rise as the foot pedal is pumped. Depressing the release lever will lower the table at a controlled rate of descent.

In the event the platform has been overloaded, the pressure relief will open because of excessive pressure build-up in the hydraulic system. Oil will bypass into the reservoir. **Never** change the pressure relief setting. **Do not** exceed the rated capacity of your lift equipment.

Speed Selection for Two-speed Pumps:

This pump offers two "speeds". The low speed produces *low volume/high pressure*. The high speed produces *high volume/low pressure*. The operator has the option of selecting the optimum pump speed for the application at hand. Pump speeds are selected by sliding the "lock collar" (See item # 2A on the parts identification) in or out. An occasional drop of oil will keep the collar working freely.

Air Bleed Procedure:

Whether your pump is a new installation, or has been recently serviced, air has likely entered the hydraulic system. The design of this pump includes an "air bleed screw" which will aid in the removal of unwanted air from the foot pump area of the hydraulic system. Use the following steps to remove this air from the system.

- 1) Check all fittings to be sure they are tight. Ensure that the oil is filled to within 1" of the top of the reservoir when the lift is in the fully lowered position.
- 2) Locate the "air bleed screw" (See item # 33 on the pump body) and loosen approximately 1/2 turn counterclockwise. As soon as you have loosened the screw, slowly depress the foot pedal. This will force the air out of the pump chamber. Before you let the pump pedal return to the "up" or "home" position, tighten the air bleed screw. This will prevent air from re-entering the pump chamber. Repeat the above procedure until the pump chamber is completely filled with oil and a "spongy" feel is no longer present. If the air bleeding procedure has been successful, the feel of the pump pedal will be firm and the complete stroke of the pump will produce fluid flow.

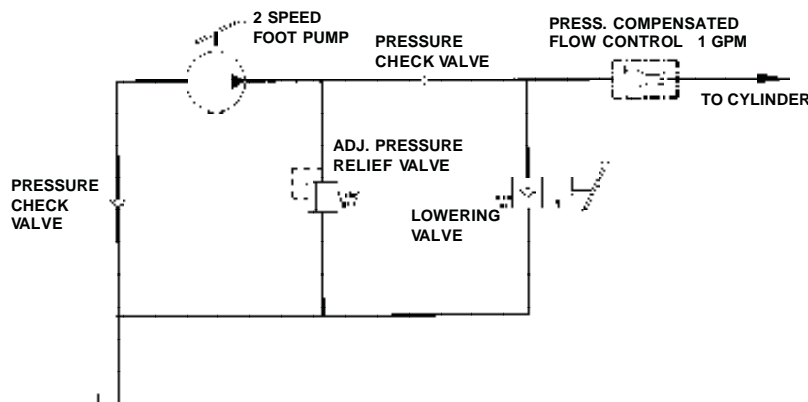
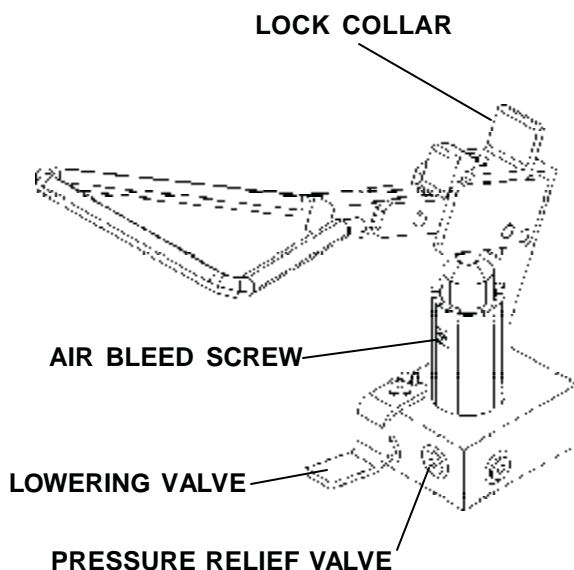

WARNING LABEL IDENTIFICATION

MAKE SURE ALL WARNING LABELS ARE IN PLACE!

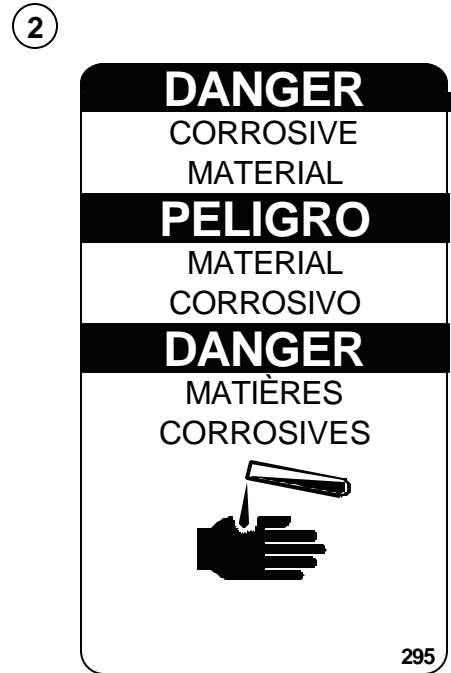
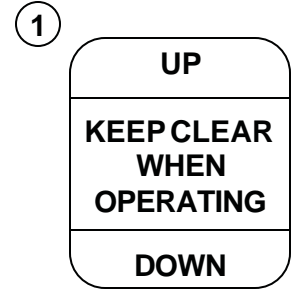
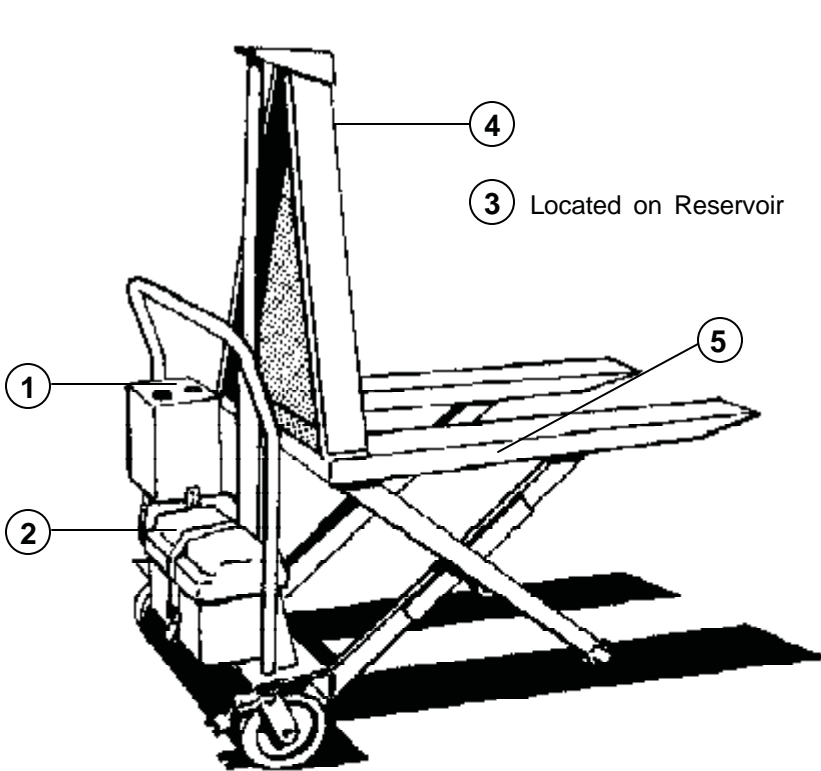

*Product safety signs or labels should be periodically inspected and cleaned by the product users as necessary to maintain good legibility for safe viewing distance . . . ANSI 535.4 (10.21)
Contact manufacturer for replacement labels if needed.

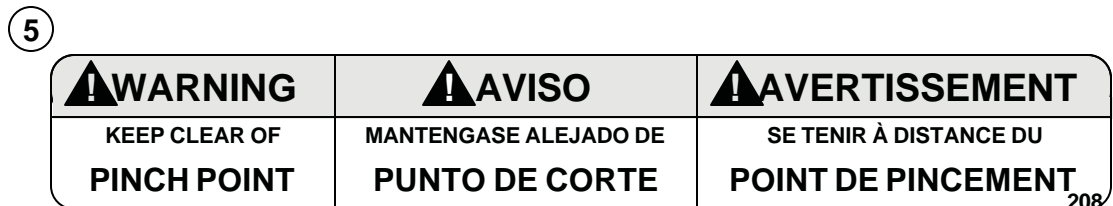
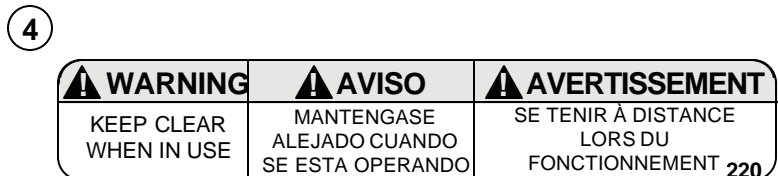
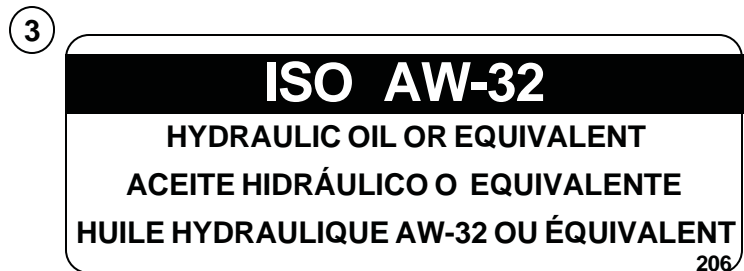

LIMITED WARRANTY

ONE YEAR LIMITED WARRANTY. The manufacturer warrants for the original purchaser against defects in materials and workmanship under normal use one year after date of purchase. (Not to exceed 15 months after date of manufacture.) Any part which is determined by the manufacturer to be defective in material or workmanship and returned to the factory, shipping costs prepaid, will be, as the exclusive remedy, repaired or replaced at our option. Labor costs for warranty repairs and/or modifications are not covered unless done at manufacturer's facilities. Any modifications performed without written approval of the manufacturer may void warranty. This limited warranty gives purchaser specific legal rights which vary from state to state.

LIMITATION OF LIABILITY. To the extent allowable under applicable law, the manufacturer's liability for consequential and incidental damages is expressly disclaimed. The manufacturer's liability in any event is limited to, and shall not exceed, the purchase price paid. Misuse or modification may void warranty.

WARRANTY DISCLAIMER. Our company has made a diligent effort to illustrate and describe the products shown accurately; however, such illustrations and descriptions are for the sole purpose of identification, and do not express or imply a warranty that the products are merchantable, or fit for a particular purpose, or that the products will necessarily conform to the illustrations or descriptions.

The provisions of the warranty shall be construed and enforced in accordance with the UNIFORM COMMERCIAL CODE and laws as enacted in the State of Indiana.

DISPOSITION. Our company will make a good faith effort for prompt correction or other adjustment with respect to any product which proves to be defective within the Limited Warranty. Warranty claims must be made in writing within said year.

SERVICE RECORD

DATE OF SERVICE: ____/____/____
WORK DONE BY: _____
SERVICE PERFORMED: _____

DATE OF SERVICE: ____/____/____
WORK DONE BY: _____
SERVICE PERFORMED: _____

DATE OF SERVICE: ____/____/____
WORK DONE BY: _____
SERVICE PERFORMED: _____

DATE OF SERVICE: ____/____/____
WORK DONE BY: _____
SERVICE PERFORMED: _____

DATE OF SERVICE: ____/____/____
WORK DONE BY: _____
SERVICE PERFORMED: _____

DATE OF SERVICE: ____/____/____
WORK DONE BY: _____
SERVICE PERFORMED: _____

