



Beacon Industries, Inc,  
 12300 Old Tesson Rd., St. Louis, MO 63128  
 Telephone: (314) 487-7600 -or- Toll Free (800) 454-7159  
 Fax: (314) 487-0100  
 Web: www.beacontechnology.com  
 Email: info@beacontechnology.com

## BHBD-Series Hydraulic Box Dumpers Instruction Manual



### Receiving instructions:

After delivery, remove the packaging from the product. Inspect the product closely to determine whether it sustained damage during transport. If damage is discovered, record a complete description of it on the bill of lading. If the product is undamaged, discard the packaging.

### NOTE:

The end-user is solely responsible for confirming that product design, use, and maintenance comply with laws, regulations, codes, and mandatory standards applied where the product is used.

### Replacement Parts and Technical Service:

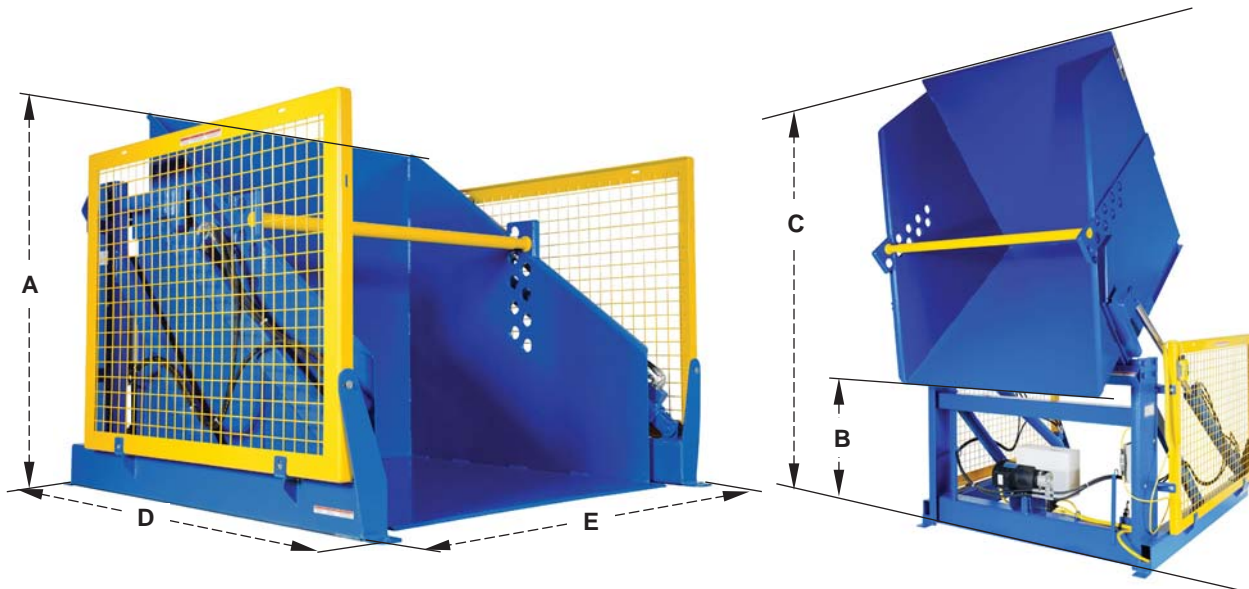
For answers to questions not addressed in these instructions and to order replacement parts, labels, and accessories, call our Technical Service and Parts Department at (314) 487-7600.

### Table of Contents

|  |              |
|--|--------------|
| Specifications.....                                  | 2            |
| Signal Words.....                                    | 3            |
| Safety Instructions.....                             | 3            |
| Installation.....                                    | 4            |
| Loading the Dumper.....                              | 4            |
| Inspections.....                                     | 5            |
| Power Unit Operation.....                            | 5, 6         |
| Figs. 1, 2, & 3: Electric Circuit Diagrams .....     | 7, 8, & 9    |
| Fig. 4: Motor & Transformer Connection Diagrams..... | 10           |
| Figs. 5A, 5B, & 5C: Electrical Circuit Diagrams..... | 11, 12, & 13 |
| Figs. 6A & 6B: Hydraulic Circuit Diagrams.....       | 14           |
| Figs. 7A, 7B, & 7C: Exploded Parts Diagrams.....     | 15, 16, & 17 |
| Installing Option BHBD-GATE.....                     | 18           |
| Troubleshooting.....                                 | 19           |
| Limited Warranty.....                                | 20           |
| Labeling Diagram.....                                | 21           |

## SPECIFICATIONS

Our dumpers are rigorously engineered to provide safety-enhancing features while preserving simplicity. Standard design features include: 2HP, 3-phase motor; cast iron pump that integrates pressure relief, check, down solenoid, and pressure compensated flow control valves; expanded metal machine side-guards; hydraulic actuators with internal brass velocity fuse and stainless steel spring; and 24V fused control circuit. Dimensions, net weight, and capacity information are provided in the following diagrams and table.



| Model     | A: Max. height with chute retracted        | B: Dump height | C: Max. height with chute extended          | Chute usable dimensions [W x L] | D: Overall length                          | E: Overall width | Capacity              | Net weight           |
|-----------|--|----------------|---|---------------------------------|--|------------------|-----------------------|----------------------|
| BHBD-2-36 | 53 <sup>1</sup> / <sub>2</sub> "<br>136 cm | 36"<br>91 cm   | 111"<br>282 cm                              | 52" x 50"<br>(132 x 127)cm      | 68 <sup>1</sup> / <sub>2</sub> "<br>174 cm | 69"<br>176 cm    | 2,000 lb.<br>909 kg   | 1631 lb.<br>741.2 kg |
| BHBD-2-48 | 65"<br>165 cm                              | 48"<br>122 cm  | 129 <sup>1</sup> / <sub>2</sub> "<br>329 cm | 52" x 50"<br>(132 x 127)cm      | 68 <sup>1</sup> / <sub>2</sub> "<br>174 cm | 69"<br>176 cm    | 2,000 lb.<br>909 kg   | 1787 lb.<br>812.2 kg |
| BHBD-2-60 | 77"<br>196 cm                              | 60"<br>152 cm  | 149 <sup>1</sup> / <sub>2</sub> "<br>380 cm | 52" x 50"<br>(132 x 127)cm      | 68 <sup>1</sup> / <sub>2</sub> "<br>174 cm | 69"<br>176 cm    | 2,000 lb.<br>909 kg   | 1948 lb.<br>885.5 kg |
| BHBD-4-36 | 53 <sup>1</sup> / <sub>2</sub> "<br>136 cm | 36"<br>91 cm   | 111"<br>282 cm                              | 52" x 50"<br>(132 x 127)cm      | 68 <sup>1</sup> / <sub>2</sub> "<br>174 cm | 69"<br>176 cm    | 4,000 lb.<br>1,818 kg | 1655 lb.<br>752.1 kg |
| BHBD-4-48 | 65"<br>165 cm                              | 48"<br>122 cm  | 129 <sup>1</sup> / <sub>2</sub> "<br>329 cm | 52" x 50"<br>(132 x 127)cm      | 68 <sup>1</sup> / <sub>2</sub> "<br>174 cm | 69"<br>176 cm    | 4,000 lb.<br>1,818 kg | 1859 lb.<br>844.8 kg |
| BHBD-4-60 | 77"<br>196 cm                              | 60"<br>152 cm  | 149 <sup>1</sup> / <sub>2</sub> "<br>380 cm | 52" x 50"<br>(132 x 127)cm      | 68 <sup>1</sup> / <sub>2</sub> "<br>174 cm | 69"<br>176 cm    | 4,000 lb.<br>1,818 kg | 2020 lb.<br>918 kg   |
| BHBD-6-36 | 53 <sup>1</sup> / <sub>2</sub> "<br>136 cm | 36"<br>91 cm   | 111"<br>282 cm                              | 52" x 50"<br>(132 x 127)cm      | 68 <sup>1</sup> / <sub>2</sub> "<br>174 cm | 69"<br>176 cm    | 6,000 lb.<br>2727 kg  | 1808 lb.<br>795kg    |
| BHBD-6-48 | 65"<br>165 cm                              | 48"<br>122 cm  | 129 <sup>1</sup> / <sub>2</sub> "<br>329 cm | 52" x 50"<br>(132 x 127)cm      | 68 <sup>1</sup> / <sub>2</sub> "<br>174 cm | 69"<br>176 cm    | 6,000 lb.<br>2727 kg  | 1988 lb.<br>903.3 kg |
| BHBD-6-60 | 77"<br>196 cm                              | 60"<br>152 cm  | 149 <sup>1</sup> / <sub>2</sub> "<br>380 cm | 52" x 50"<br>(132 x 127)cm      | 68 <sup>1</sup> / <sub>2</sub> "<br>174 cm | 69"<br>176 cm    | 6,000 lb.<br>2727 kg  | 2021 lb.<br>919kg    |

## SIGNAL WORDS

This manual classifies personal injury risks and situations that might cause property damage with signal words. Signal words indicate the seriousness of injuries that might result if a particular act does, or does not, occur.



Identifies a hazardous situation which, if not avoided, **WILL** result in **DEATH** or **SERIOUS INJURY**. Use of this signal word is limited to the most extreme situations.



Identifies a hazardous situation which, if not avoided, **COULD** result in **DEATH** or **SERIOUS INJURY**.



Indicates a hazardous situation which, if not avoided, **COULD** result in **MINOR** or **MODERATE** injury.



Identifies practices likely to result in product/property damage, such as operation that might damage the product.

## SAFETY INSTRUCTIONS

We strive to identify all hazards associated with the use of our products. However, material handling is dangerous and no manual can address every risk. The most effective way to avoid injury is for the end-user to exercise sound judgment whenever using this product.



Electrocution might result if any part of the dumper contacts electrified wires. Reduce the likelihood that platform occupants or bystanders might be electrocuted by applying **common sense**:

- DO NOT *contact* electrified wires with any part of the dumper;
- DO NOT install the BHBD in an area where contact with electrified wires is likely;
- DO NOT use the dumper *close to* electrified wires or other sources of electricity;
- Before using the dumper, always inspect the usage area for unusual conditions that require special precautions.



Material handling is dangerous. Improper or careless operation might result in serious personal injuries sustained by the operator(s) and/or bystanders. Work platform users should conform to the following:

- ONLY use the box dumper as a means for mechanically emptying appropriately sized (see "Load the dumper" on p. 4-5) boxes, crates and other containers. ALWAYS properly load the dumper according to the directions on p. 4-5.
- DO NOT use a damaged dumper. Examples of structural damage include: broken container restraining tube, broken fork pockets, and holes caused by rust or corrosion. Inspect the dumper before each use according to the **INSPECTION** instructions on p. 5. DO NOT use the BHBD unless it passes *every* element of the inspection, or until authorized maintenance personnel approve the dumper for service.
- Inspect the unit before each use according to the **INSPECTION** instructions on p. 5.
- DO NOT stand beneath or travel under the dumper chute while it is elevated or allow others to do so.
- DO NOT use this machine UNLESS each label shown in the **LABELING DIAGRAM** on p. 21 is affixed to it, undamaged, and readable. Contact **TECHNICAL SERVICE** to order replacement labels.
- DO NOT exceed the maximum rated load (capacity) of the dumper. The weight of the container to be dumped plus the weight of its contents must not exceed the maximum rated load of the dumper.
- DO NOT modify the box dumper in any way without first obtaining written approval from Beacon. Unauthorized modifications might make the dumper unsafe to use, and could result in operator and/or bystander injury.
- Standard units are not designed for high cycle use. High cycle use of a standard unit could lead to premature failure of the main hinge pins. High cycle use is defined as 12-15 motor starts per hour for 3 or more consecutive hours.



DO NOT fill the hydraulic system with brake fluid or jack oils. Only fill the hydraulic system with either anti-wear hydraulic oil, viscosity grade 150 SUS at 100°F (ISO 32cSt at 40°C) or Dexron transmission fluid.

## RECORD OF SATISFACTORY CONDITION

Before putting this machine into service, document its appearance and operation. Photograph the unit from multiple vantage points in the lowered and fully elevated/dumping position. Take close range photographs of all labeling applied to the machine. Also photograph pivot points and fasteners (pins, bolts, nuts, etc.). Describe the motion of the chute as it elevates and descends, e.g. smoothly and evenly from side-to side without binding or lurching. Describe the sound of the machine as it operates. Collate all photographs and writings into a file and mark the file appropriately to identify it. This file is a record of the unit in satisfactory condition. Compare the results of all inspections to this record to determine whether the machine is in satisfactory condition. Purely cosmetic changes, like damaged surface coating (powdercoat or paint), are not changes from satisfactory condition.

## INSTALLATION

Responsibility for compliance will local building code(s) requirements, municipal/county ordinances, etc. rests exclusively with the end-user. The instructions that appear below are recommendations about essential, minimum steps necessary for safe installation. If law enforced where the dumper is used requires you to depart from these directions, Beacon is not responsible for *any* consequential damages sustained as a result of the installation. Installation requires at least:

- Forklift rated for loads equal to the net weight of your BHBD model (see Table on p. 2);
- Lag bolts: ½ in. by at least 4in. (length) [approximately equivalent to 1.3cm by at least 10.2cm]
- Masonry drill and ½ in. masonry drill bit
- Wrench: ½ in.
- Grout and steel shims
- Power supply circuit: matched to motor voltage and current requirements (see Label 250 in “Labeling Diagram” on p. 21).

**NOTE:** End-user responsible for providing overcurrent and short circuit protection.

**Step 1:** Position the dumper as desired with a forklift.

**Step 2:** Drill holes approximately 4in. (10cm) deep.

**Step 3:** Secure the dumper to the floor by inserting the lag bolts through the (5/8 in.) bolt holes in the anchor brackets (dotted lines in diagram).

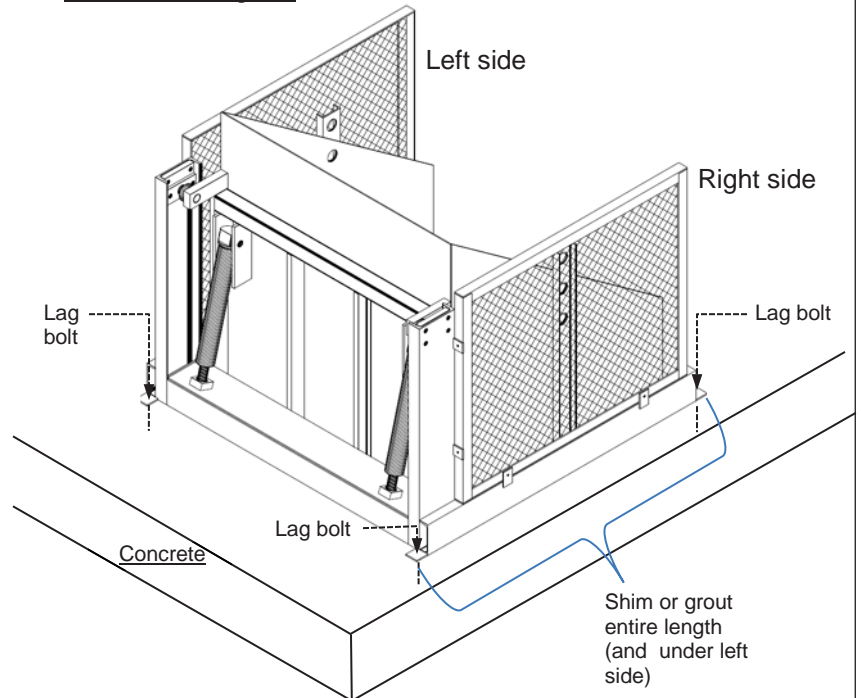
**Step 4:** Shim and/or grout the sides of the frame.

**Step 5:** Connect the power cord to the power supply.

**Step 6:** Run the dumper through several complete cycles. Press the “UP” button of the hand controller until the chute raises as far as it can, and then lower it completely. Repeat the cycle a few more times to confirm that the product operates properly.

**Step 7:** Check the oil level in the reservoir. Fully raise the chute (to the 45° “dumping position,” and then observe the level of oil in the reservoir. The surface of the oil should be 1 to 1½ inches below the fill hole.

Installation diagram



## LOADING THE DUMPER

1. Use only properly sized waste containers: HBD's are designed to dump open-top containers. Container width should be at least ½ the width of the chute, and container height should be at least ¾ the height of the chute.
2. Place the container inside the chute: the back of the container should rest against the back of the chute.
3. Insert retaining tube: to prevent the container from sliding out of the chute along with the trash, install the container-retaining tube through the sockets that are most closely matched to the height of the container. The top of the container should not be more than 5 inches (~12½ cm) below the tube.
4. Dump the container: press the “UP” button on the pendant controller to raise the chute to the dumping position. The cylinders will extend, which raises the chute, only while the operator presses the “UP” button. When the operator releases the UP button, the chute will maintain its position as of the instant the button is released.

**NOTE:** If the net weight of the container and its contents exceeds the maximum rated load of the dumper, a relief valve (incorporated into the hydraulic system) will open. While the relief valve is open, the hydraulic cylinders will not extend, and therefore the chute will not raise/dump.

5. Return the chute to the loading position: press the “DOWN” button on the controller—the cylinders will retract, which pulls the chute toward the ground. If the DOWN button is released before the chute is completely retracted, it will maintain its position. Always completely lower the chute.

Models rated for up to 6,000 pounds (2,727kg) include a lower limit switch that prevents the cylinders from retracting more than necessary to lower the chute to the loading position.



## INSPECTIONS

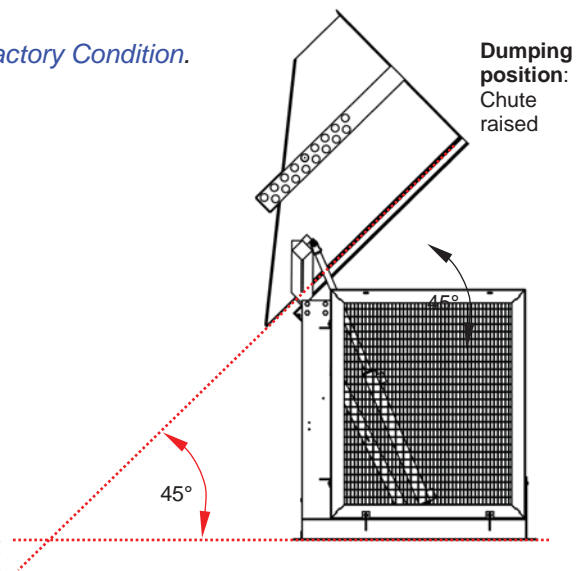
Compare the results of each inspection to the *Record of Satisfactory Condition*.

Do not use the machine unless it is in satisfactory condition.

**Before each use**, inspect the listed components:

1. Wires: look for frays;
2. Hydraulic system: check lines for chafes, pinches or leaks, and the reservoir for punctures or leaks;
3. Container-restraining tube (and holes in the chute that receive each end of the tube): Damage, deformation, looseness of fit.
4. Frame: check the cylinder brackets, vertical and horizontal frame members, horizontal cross-member, and angle cross member, hinge blocks, and pivot shaft and spacer assemblies for cracking, deformation and corrosion;
5. Limit switches: Cycle the chute. The chute should not rotate beyond approximately 45 degrees or below 0 degrees. See FIG. 1.

Listen for unusual sounds that might indicate binding or grinding during operation and watch for erratic movement(s). Contact maintenance personnel if you observe any unusual sound or movement and do not use the dumper until approved for service.



**At least once per month**, inspect the dumper as follows:

1. Oil level: fully raise the chute (to the 45°) “dumping position,” and then observe the level of oil in the reservoir. The surface of the oil should be 3 to 3½ inches below the fill hole.;
2. Pivot points: check the dumper for excessive wear at the pivot points between hydraulic cylinders and cylinder brackets, and between pivot shafts and hinge blocks;
3. Floor connection points: anchor bolts should prevent the frame from lifting off of the ground during chute operation. Concrete around each anchor bolt should be intact—no cracking or flaking;
4. Fasteners: check each fastener connection. Tighten any loose connection;
5. Hoses and wires: check each wire and hose for damage (fraying, binding, etc.);
6. Labels: labels should be easily readable and undamaged, affixed to the dumper in the locations as shown in the *Labeling Diagram* on p. 21.
7. Container-restraining tube (and the openings in the chute that receive each end of the tube): inspect the tube for damage deformation, looseness of fit.

*At least once per year*, change the hydraulic oil if it becomes gritty or looks milky (water present in the oil). With the chute in the fully lowered position, drain the oil and replace it with either Dexron transmission fluid or anti-wear hydraulic oil, viscosity grade 150 SUS at 100°F (ISO 32 cSt at 40°C).

## POWER UNIT OPERATION

**NOTE 1:** Box dumpers made after 12/01/18 receive a redesigned modular power unit, designated MPU GEN2. Diagrams and operation instructions for GEN2 power units are provided in a separate instruction manual.

**NOTE 2:** Standard BHBD units, i.e. not equipped with high cycle power unit, are not designed for high cycle use. High cycle use is defined as 12-15 motor starts per hour for 3 or more consecutive hours. If your application requires high cycle use, you must upgrade the standard power unit with a high cycle power unit.

The box dumper utilizes an electric motor directly coupled to a gear pump to pressurize the hydraulic fluid. Fluid pressure moves the cylinders up or down, and this movement performs the work required to raise and lower the chute. A hydraulic manifold bolted directly onto the gear pump houses the hydraulic control components; each component is rated for 3,000psi working pressure.

Important components of the power unit include:

- Electric motor: when ordered, the owner of this box dumper selected either a single-phase or three-phase AC motor. Regardless of phase capabilities, every motor is dual-voltage capable.
- Gear pump: shaft coupled directly to the shaft of the electric motor. Several displacements are available and correspond to the horsepower of the motor selected.
- Check valve (BHBD-2-## and BHBD-4-## models): prevents backflow of fluid through the pump and thereby allows the chute maintain a given position indefinitely.
- Pressure relief valve: opens a path for fluid to flow back to the reservoir if fluid pressure exceeds 3,000psi.
- Lowering solenoid valve: electrically-operated cartridge valve with an integral screen to keep contaminants from entering the valve.
- Counterbalance valves (6,000lb. rated load models only): allow smooth motion in double-acting hydraulic circuits.

- Pressure compensated flow control spool (2,000lb. & 4,000lb. rated load models only): Located beneath the lowering valve, and regulates the fluid flow to the reservoir. This component allows the table to lower at the constant rate independent of the weight of the dumper and contents. Several sizes are available.
- Hydraulic cylinders: 2,000 lb. and 4,000 lb. (capacity) models utilize displacement style cylinders. Each cylinder includes a bleeder valve (located at top end) for removing air from the hydraulic system. 6,000 lb. capacity models use double-acting cylinders.
- Velocity fuse: Safety device installed in the hose port of each cylinder. If a hose is punctured while the BHBD is in use, the velocity fuse closes automatically. The chute remains stationary until pressure is reapplied to the system.
- Hydraulic fluid: HO150 hydraulic fluid. To replenish the fluid, add anti-wear hydraulic fluid with a viscosity grade of 150 SUS at 100°F (ISO 32 @ 40°C) like AW-32 or Dexron transmission fluid.

## SEQUENCE OF OPERATION

**A. Tilt the chute:** Press the “UP” button. The motor turns and spins the gear pump. Oil flows out of the reservoir, through the suction filter and into the pump.

- 2k & 4k rated load models: pump propels oil through the check valve to the lift cylinders.
- 6k rated load models: pressurized oil flows through the energized directional valve RT and into the blind end of the lift cylinders; then oil is pressed out of the rod end and through a counterbalance valve 2CB. Counterbalance valves prevent jerky movement as the chute reaches peak elevation (45° with horizontal).
- Releasing the UP button during operation will immediately halt all chute movement.
- An upper travel limit switch automatically turns off the motor when the chute reaches a preset 45° tilt angle.

**B. Lower the chute:** Press the “DOWN” button.

- 2k & 4k max. rated load models: lowering valve opens which bypasses the check valve and allows oil in the cylinders to flow to the reservoir (through return hoses).
- 6k max. rated load models: The motor turns and the pump pushes the pressurized oil through the energized directional valve LT and into the rod end of the lift cylinders. Oil flows from the blind ends of the cylinders and through counterbalance valve 1CB, which regulates lowering speed and smoothness. A lower limit switch turns off the motor when the chute is fully lowered.
- Releasing the DOWN button during operation causes all chute movement to stop. The chute will remain in the same position until you press the DOWN button again and allow it to lower completely.

## TROUBLESHOOTING MINOR ISSUES WITH THE HYDRAULIC SYSTEM

**A. Chute slowly lowers on its own (without pressing the DOWN button):** Remove, inspect, and clean the lowering cartridge valve.

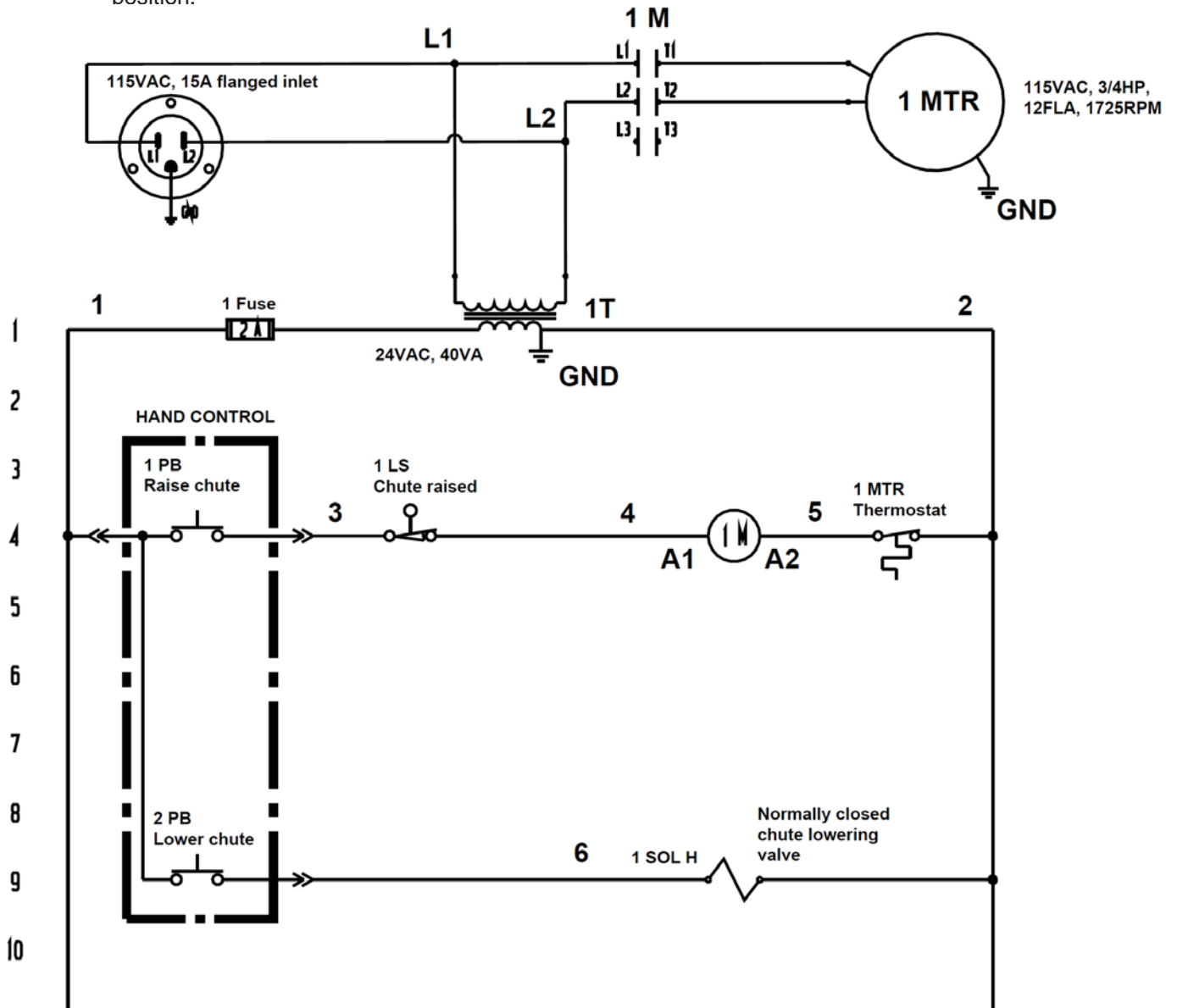
1. Lower the chute completely and unplug the AC cord.
2. If loaded, remove the container from the chute.
3. Remove the nut that fastens the solenoid coil to the valve stem, remove the coil, and then unscrew the valve from the manifold.
4. Inspect the valve for blockage(s).
5. Inspect O-rings and back-up washers for cuts, tears, etc.
6. Submerge the valve in mineral spirits or kerosene and use a thin tool, such as a small screwdriver or a hex wrench, to push the poppet in and out several times from the bottom end of the valve. The valve should move freely, about 1/16” between the closed and open positions. If the poppet sticks, the valve stem might be bent. Replace the poppet if it doesn’t free up after cleaning.
7. Remove mineral oil from the valve with compressed air.
8. Move the poppet in and out.
9. Inspect the bottom of the valve cavity in the manifold for foreign matter.
10. With the thin tool, press the middle of the flow control spool, which is located in the bottom of the cavity. It should move down and up smoothly.
11. Reinstall the valve (in the manifold) and tighten the valve with 20 lb-ft of torque.

**B. Chute lowers extremely slowly:** Air in the cylinders might be the culprit. Air closes the velocity fuse, which prevents oil from flowing out of the cylinders. **Bleed the air from the system:**

1. Lower the chute completely and unload the chute.
2. Locate the bleeder valve located at the top of each cylinder (it looks like a grease zirk). Bleed one (1) cylinder at a time. Hold a rag over the valve and open it about 1/2 turn with a 3/8” or 5/16” wrench. Oil and air will sputter from the valve. Jog the motor by pressing the UP button for just a second. If air continues to escape from the bleeder valve, jog the motor several more times. Wait at least 5 seconds between successive jogs.
3. When air no longer is observed and only a clear stream of oil flows from the bleeder valve, close the valve.
4. Check the oil level in the reservoir. If the surface of the oil is lower than 1 to 1½ in. below the fill hole, add oil until it is between 1 and 1½ inches of the fill hole.

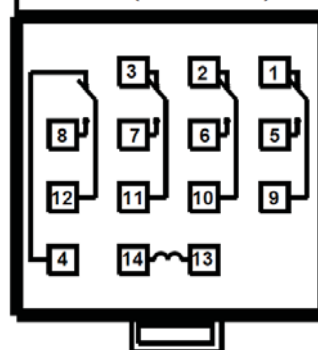
**FIG. 1:** 115VAC electrical circuit diagram for 2,000 lb. & 4,000 lb. capacity models (09124017 Rev. D)

**NOTE:** In this diagram, all components are represented with the chute in “home” location, i.e. resting, lowered position.



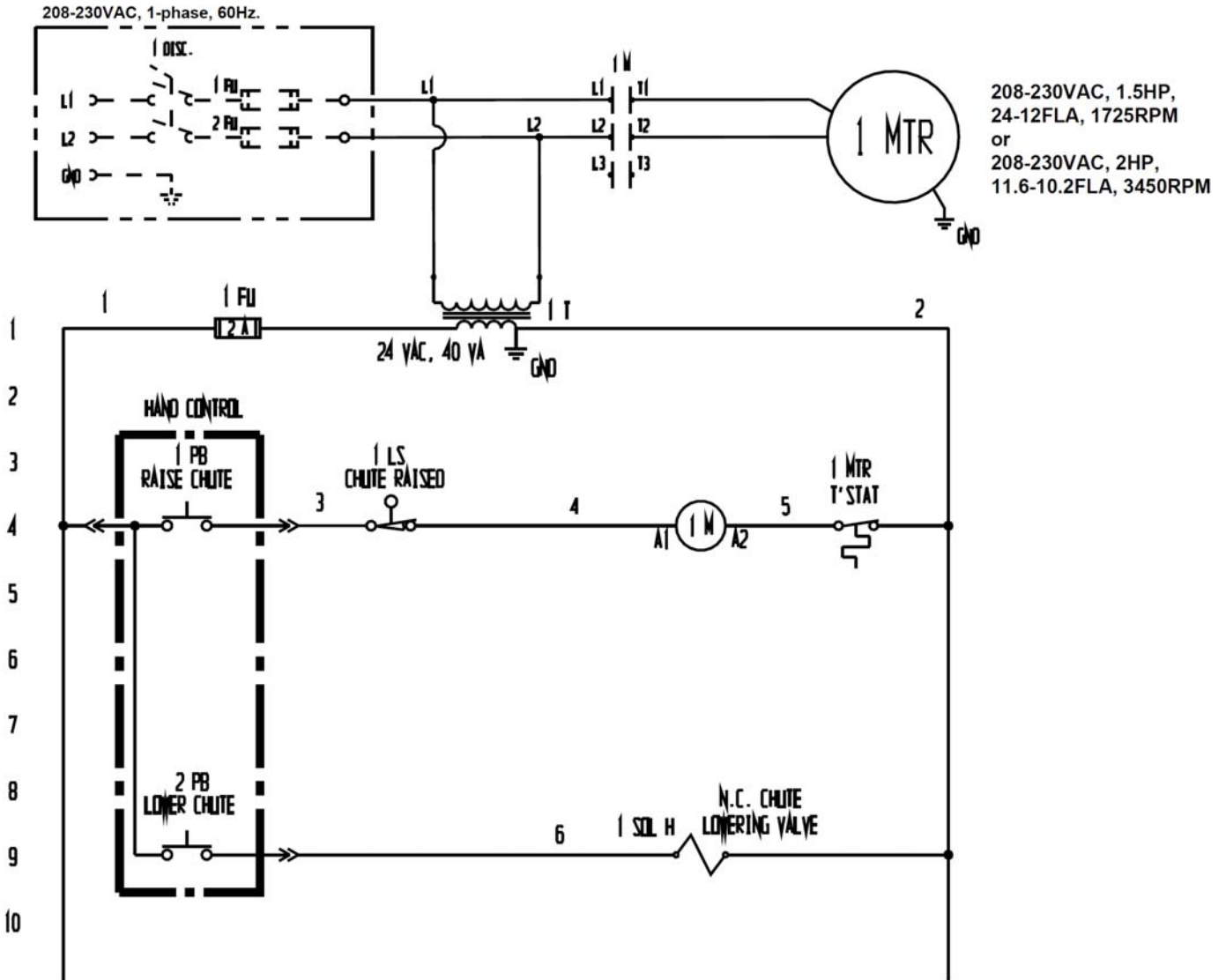
**NOTE:** Overcurrent and short-circuit protection should be provided by the end user in accordance with recommendations and requirements in NEC (NFPA 70) and local codes.

**CONTROL RELAY BASE LAYOUT (TOP VIEW)**



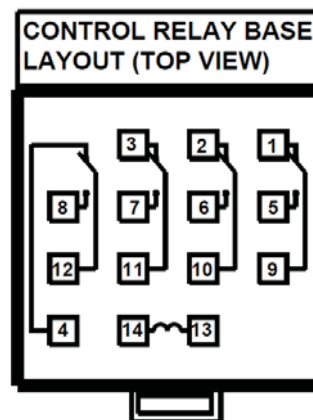
**FIG. 2:** 208-230VAC electrical circuit diagram for 2,000 & 4,000 capacity models (09124018 Rev. C)

**NOTE:** In this diagram, all components are represented with the chute in “home” location, i.e. resting, lowered position.



----- Indicates wire and/or components end-user must provide

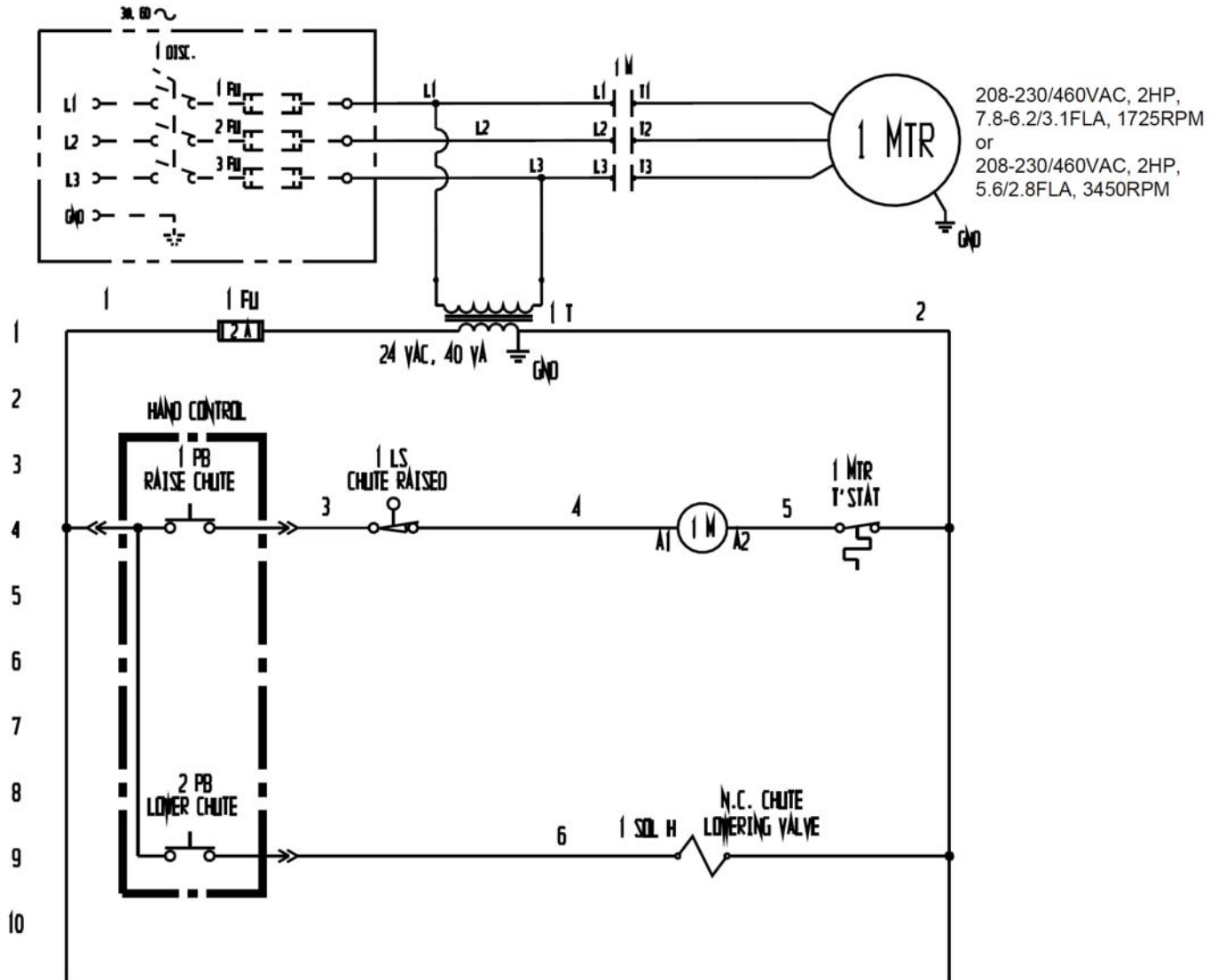
**NOTE:** Overcurrent and short-circuit protection should be provided by the end user in accordance with recommendations and requirements in NEC (NFPA 70) and local codes.





**FIG. 3:** 3-phase 208-230/460 VAC electrical circuit diagram for 2,000 & 4,000 capacity models (09124019 Rev. C)

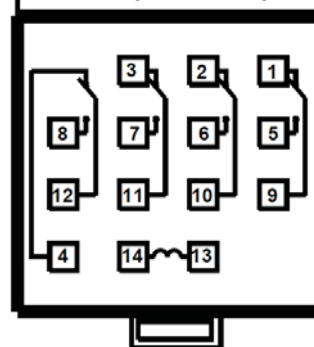
**NOTE:** In this diagram, all components are represented with the chute in “home” location, i.e. resting, lowered position.



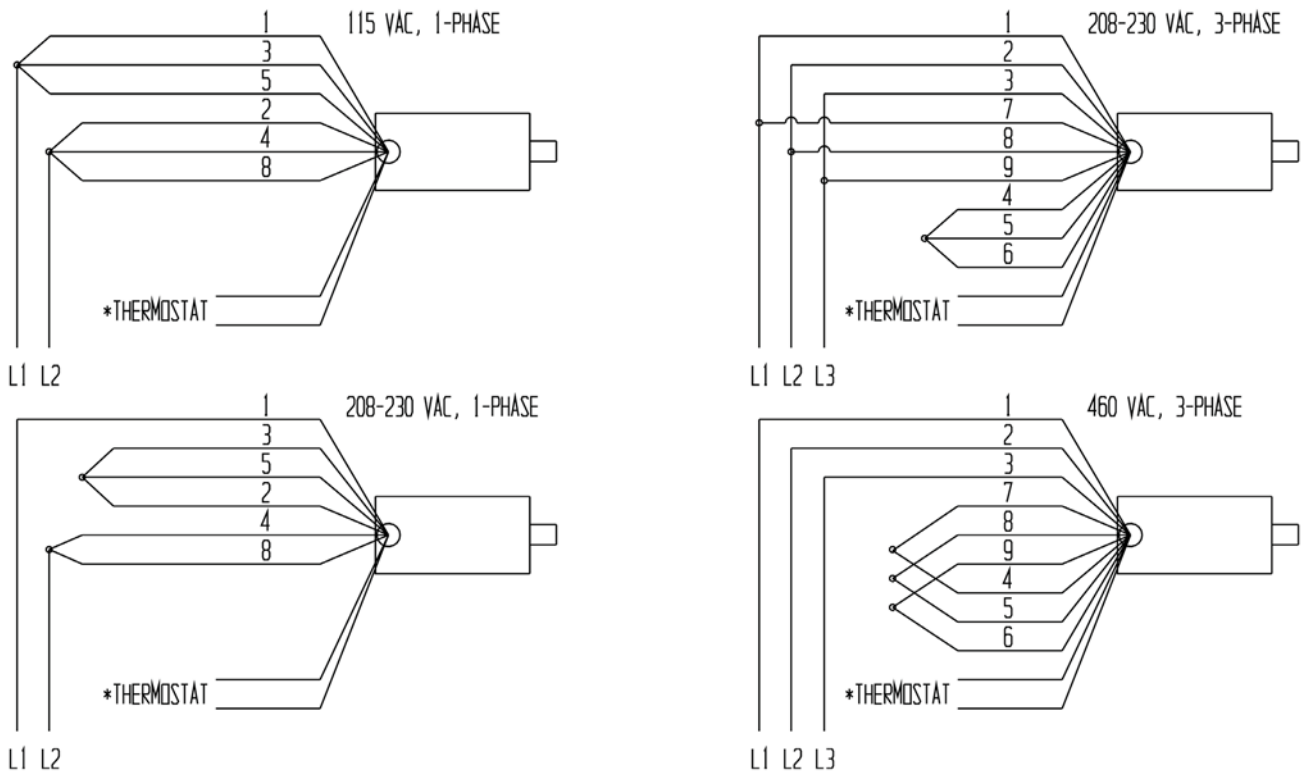
----- Indicates wire and/or components end-user must provide

**NOTE:** Overcurrent and short-circuit protection should be provided by the end user in accordance with recommendations and requirements in NEC (NFPA 70) and local codes.

**CONTROL RELAY BASE LAYOUT (TOP VIEW)**

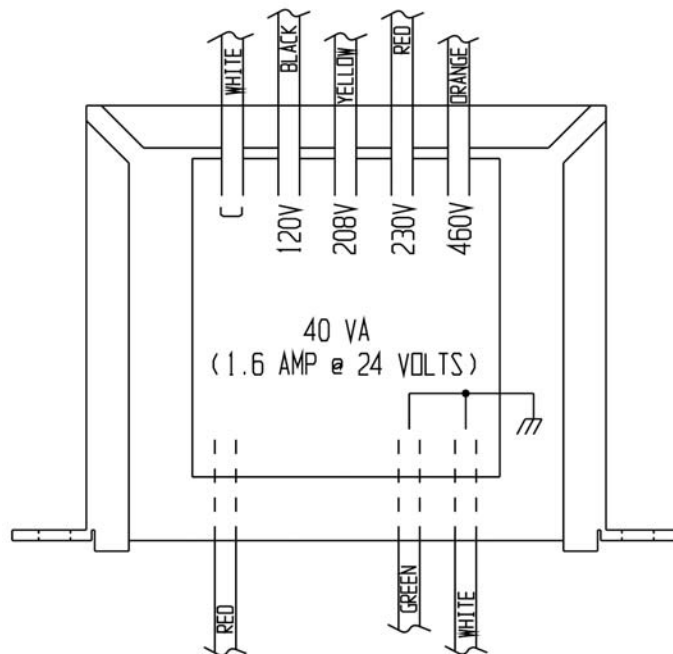


**FIG. 4:** Motor lead connection diagrams for all 0.5HP, 0.75HP, & 3hp single-phase motors and for all 2HP, 5.5HP, and 6.5HP three phase motors

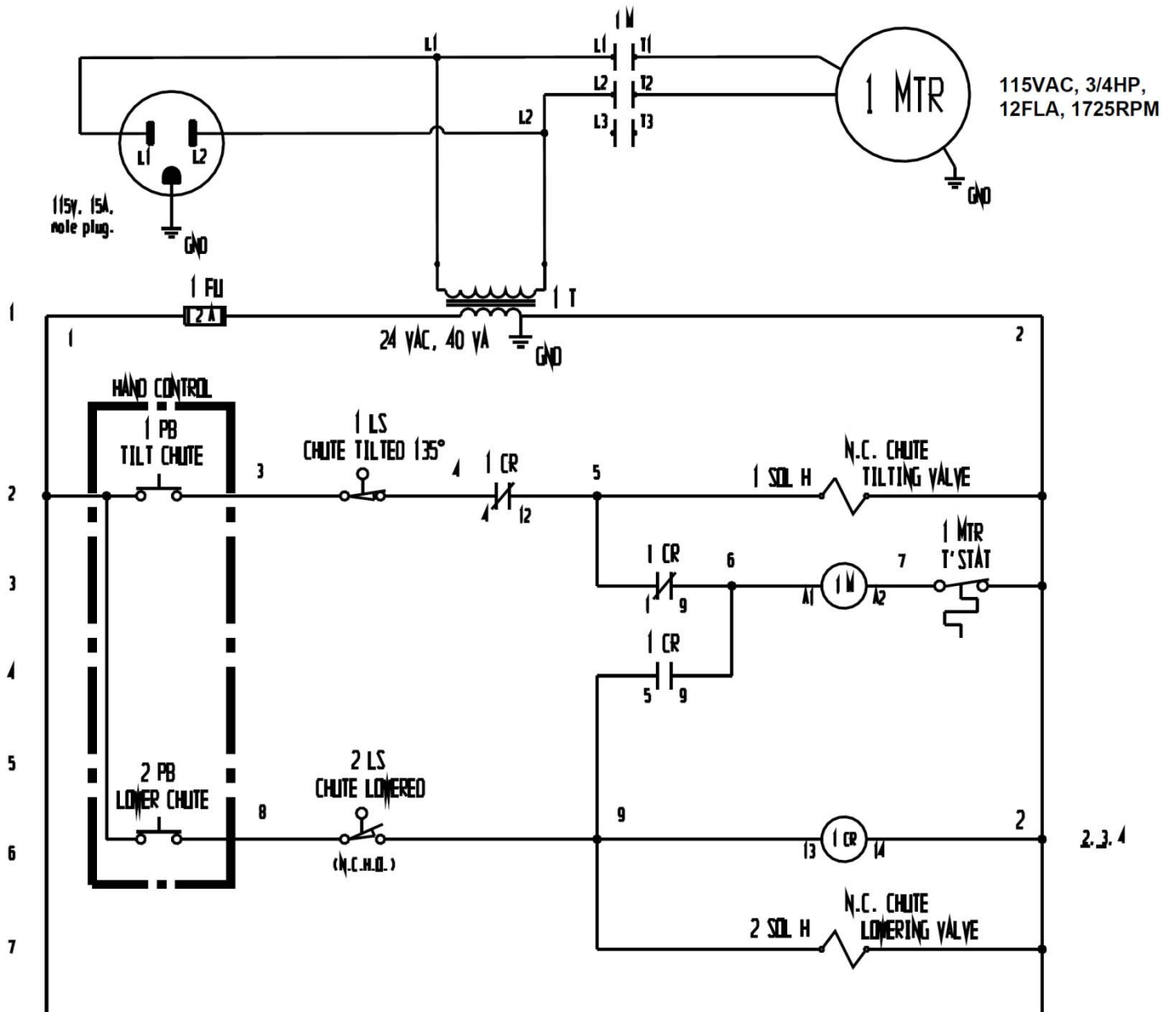


Attach thermostat leads to:  
 1) Grounded side of the transformer secondary; and  
 2) Motor relay coil.  
 It does not matter which lead attaches to each location.

**Transformer wiring diagram:**

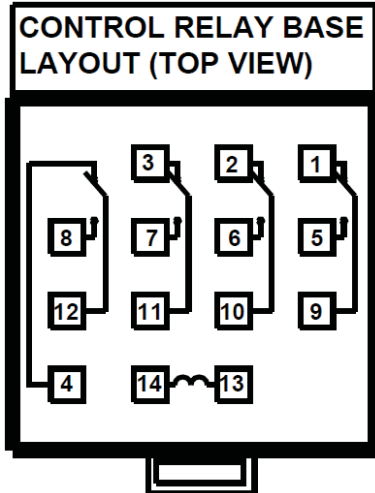


**FIG. 5A:** Double acting, 6,000lb. capacity models 115 VAC, electrical circuit diagram (09124014 Rev. C)



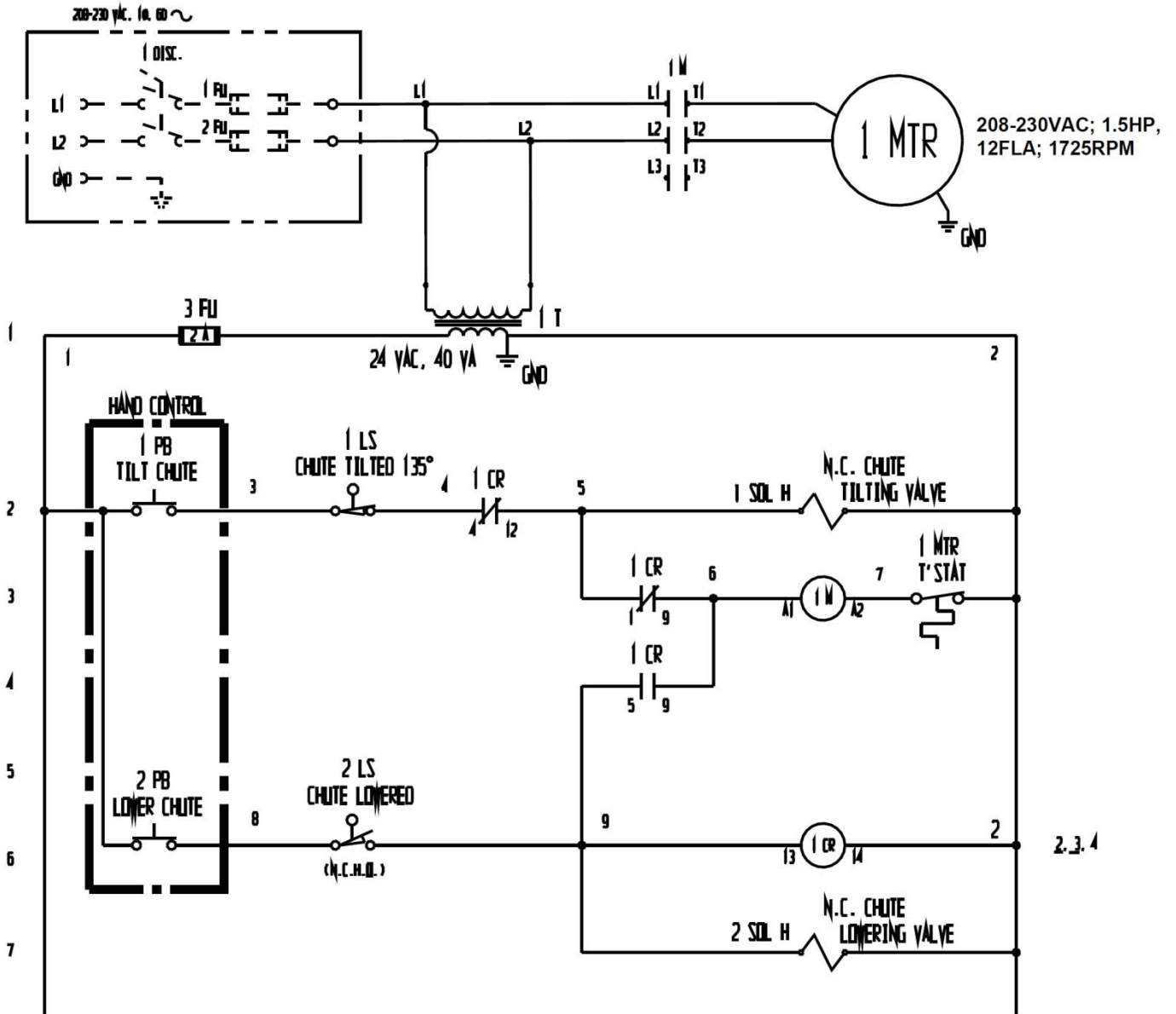
**NOTE 1:** Overcurrent and short-circuit protection should be provided by the end user in accordance with recommendations and requirements in NEC (NFPA 70) and local codes.

**NOTE 2:** In this diagram, all components are represented with the chute in "home" location, i.e. fully lowered position.



**FIG. 5B:** Double acting, 6,000lb. capacity models 208-230 VAC, single phase, electrical circuit diagram (09124015 Rev. C)

**NOTE:** In this diagram, all components are represented with the chute in "home" location. i.e. resting, lowered position.

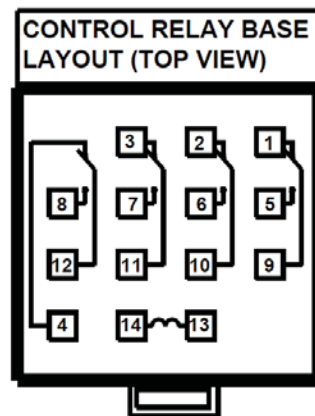


--- Indicates wire and/or components end-user must provide

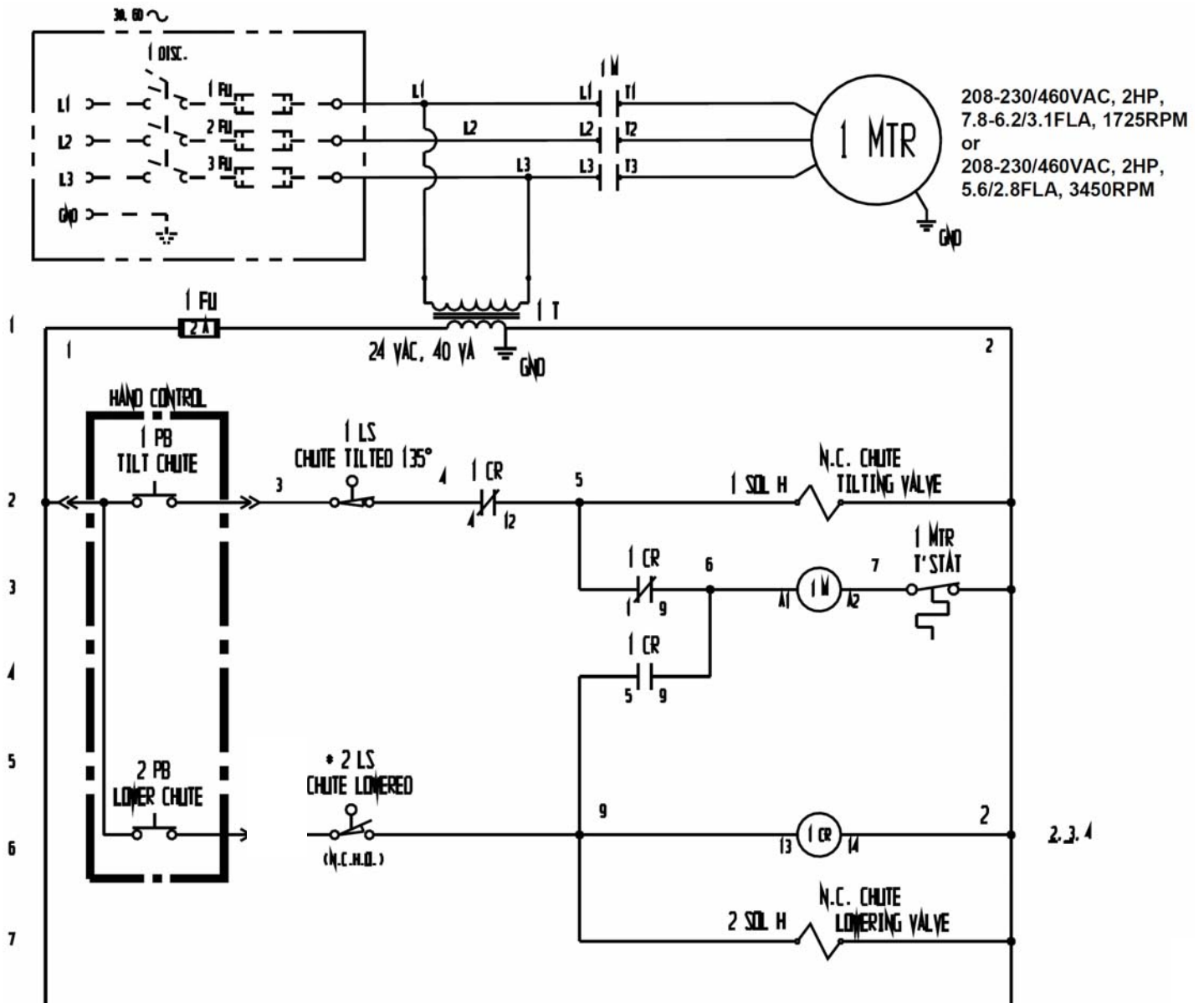
Turn off and disconnect all power before beginning work on this equipment.

**NOTE 1:** Overcurrent and short-circuit protection should be provided by the end user in accordance with recommendations and requirements in NEC (NFPA 70) and local codes.

**NOTE 2:** In this diagram, all components are represented with the chute in "home" location, i.e. resting, lowered position.



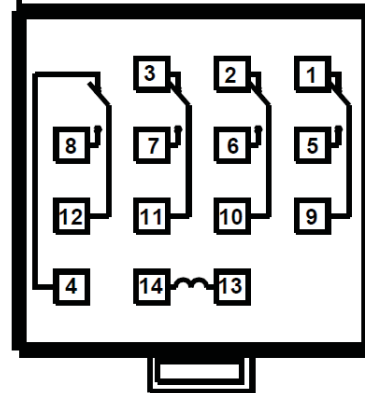
**FIG. 5C:** Double acting, 6,000lb. capacity models, 208-230/460 VAC, 3-phase, electrical circuit diagram (09124016 Rev. D)



**NOTE 1:** Overcurrent and short-circuit protection should be provided by the end user in accordance with recommendations and requirements in NEC (NFPA 70) and local codes.

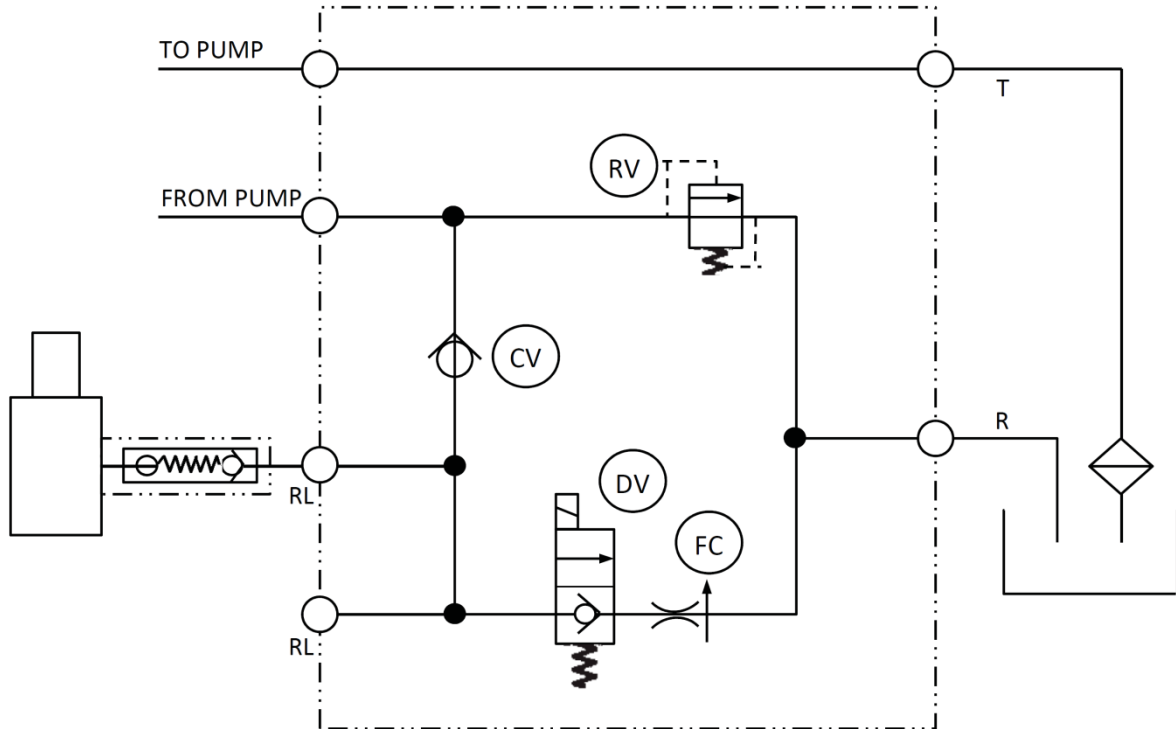
**NOTE 2:** In this diagram, all components are represented with the chute in "home" location, i.e. resting, lowered position.

**CONTROL RELAY BASE LAYOUT (TOP VIEW)**

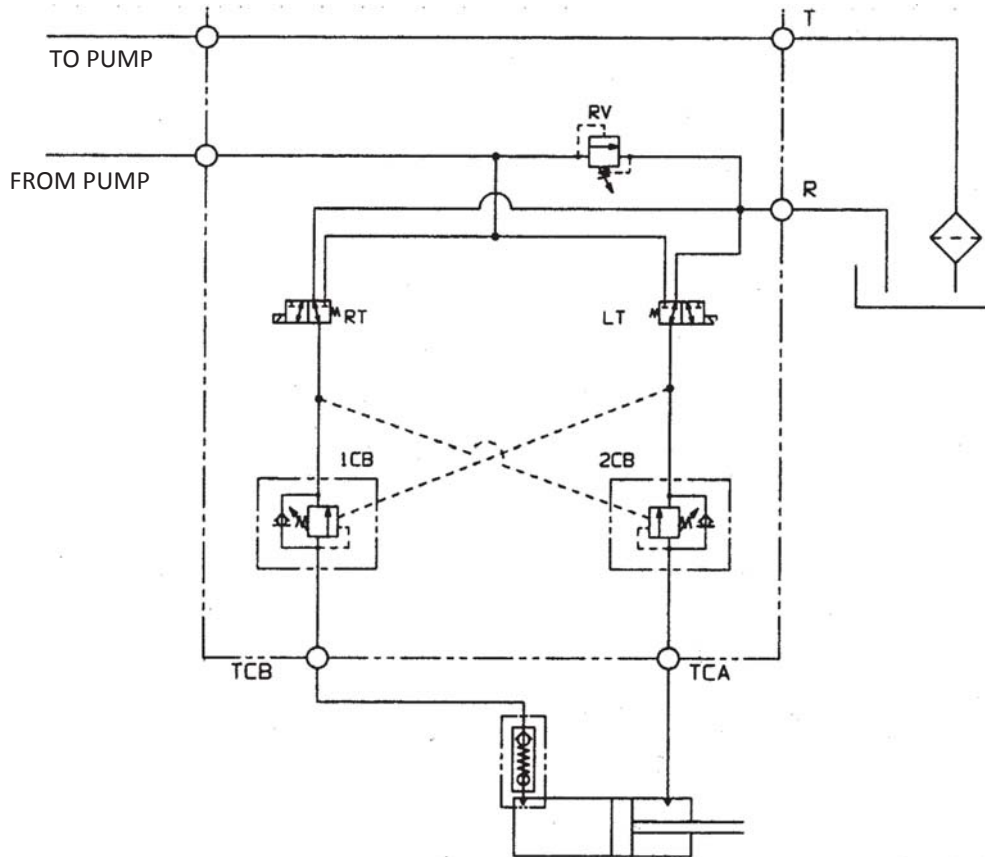




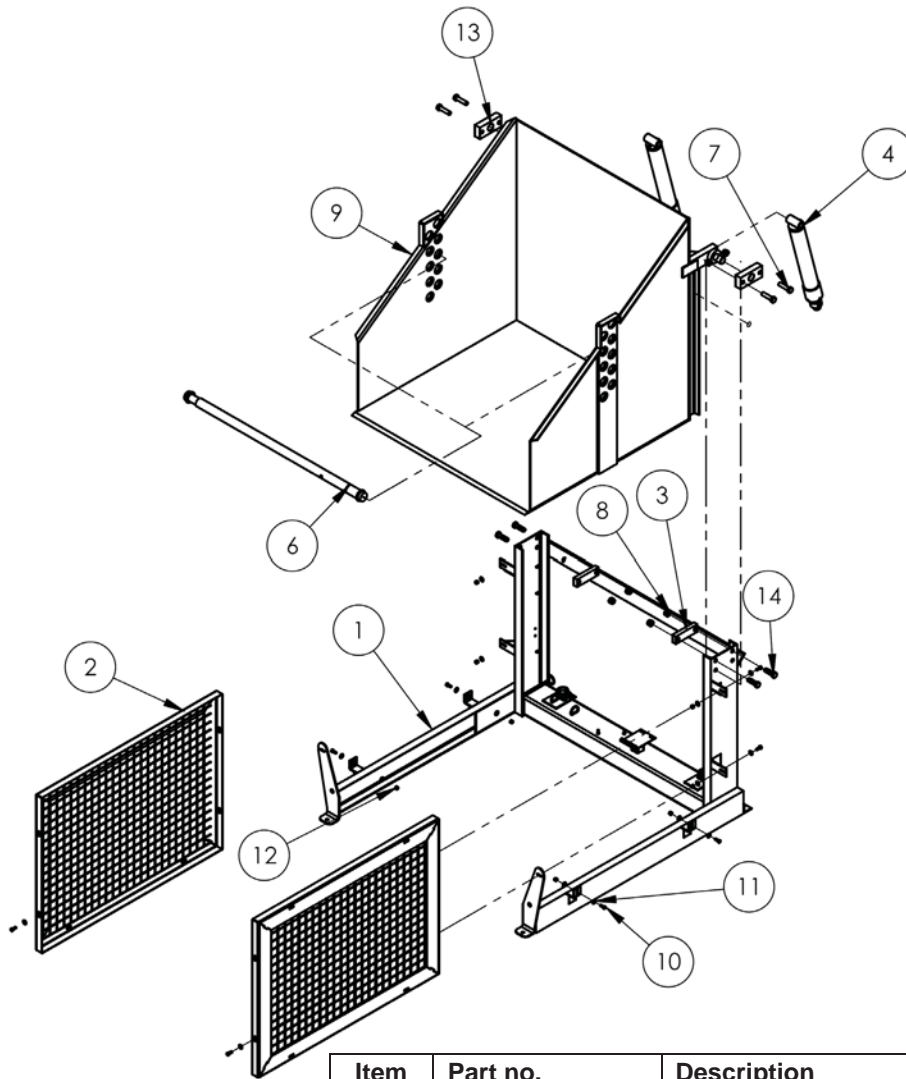
**FIG. 6A:** 2,000lb. & 4,000lb. capacity models, hydraulic circuit diagram



**FIG. 6B:** Double acting (6,000lb. capacity models) hydraulic circuit diagram

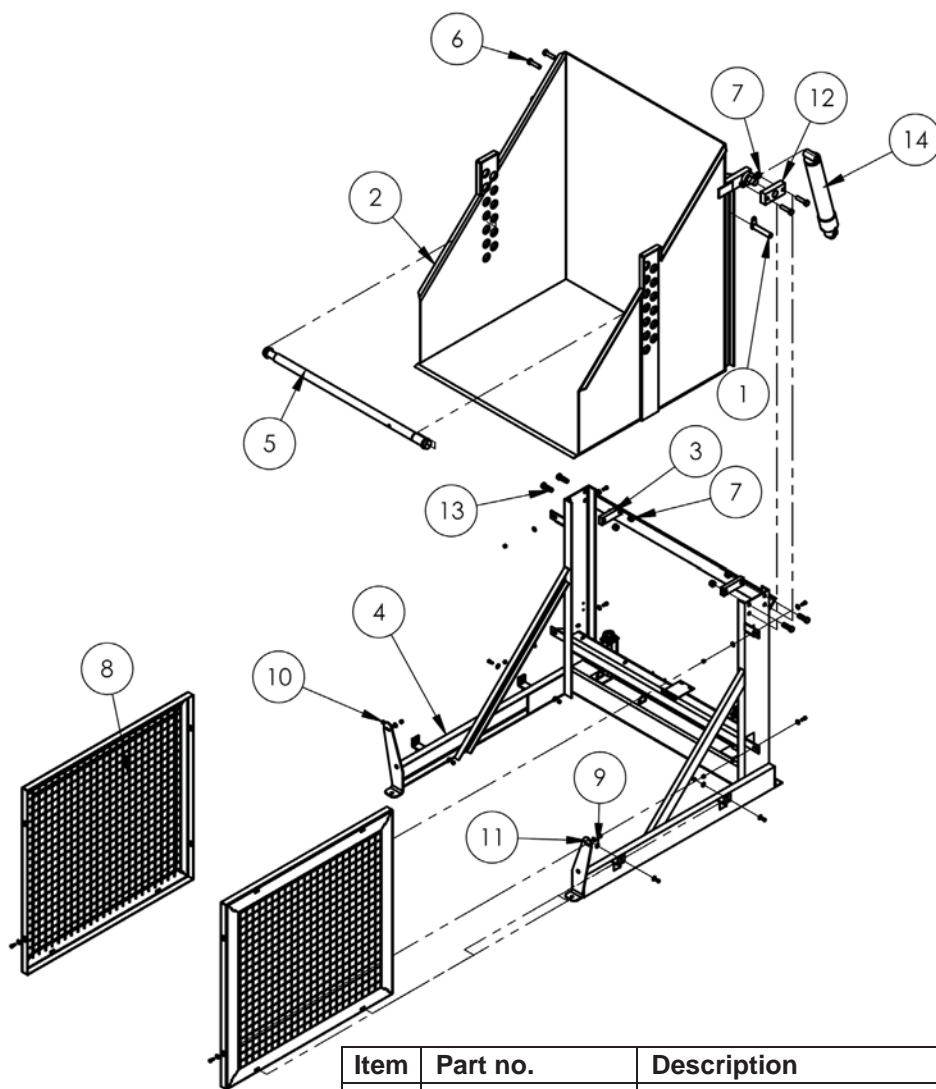


**FIG. 7A:** BHBD-2-36, BHBD-2-48, and BHBD-2-60 exploded parts diagram & bill of materials



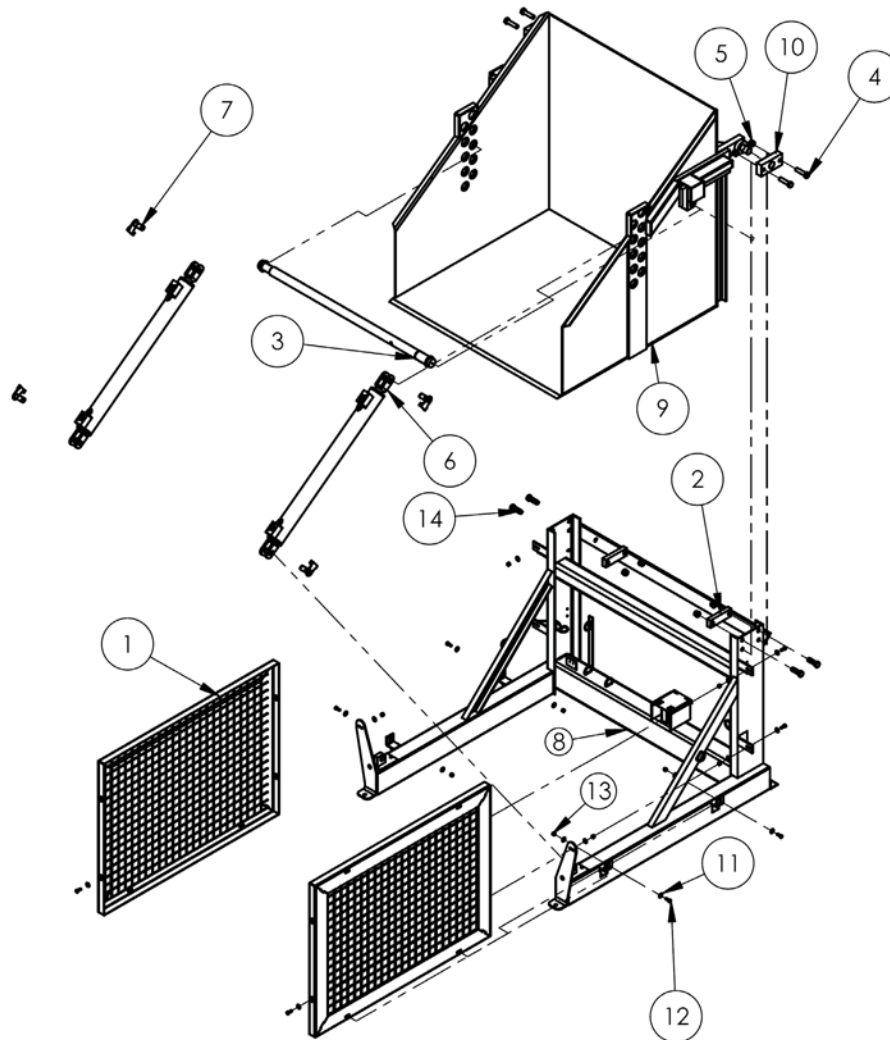
| Item | Part no.       | Description   | Quantity |
|------|----------------|---|----------|
| 1    | 34-514-007     | Base frame weldment:  | 1        |
|      | 34-514-008     | BHBD-2-36   | 1        |
|      | 34-514-009     | BHBD-2-48   | 1        |
| 2    | 34-545-024     | HCD-2-60  | 1        |
|      | 34-545-023     | Guard assembly weldment:  | 2        |
|      | 34-545-022     | BHBD-2-36   | 2        |
|      |                | BHBD-2-48   | 2        |
|      |                | BHCD-2-60   | 2        |
| 3    | 34-037-001     | Stop block  | 2        |
| 4    | 99-021-909-001 | Cylinder, 2 <sup>1</sup> / <sub>2</sub> in. x 18in.                                       | 2        |
| 5    | 09-612-003     | Pin assembly, cylinder  | 1        |
| 6    | 34-514-005     | Retaining tube assembly   | 1        |
| 7    | 13365          | <sup>3</sup> / <sub>4</sub> in. – 10 x 3in #5 zinc-plated bolt                            | 4        |
| 8    | 37039          | <sup>3</sup> / <sub>4</sub> in. – 10 zinc-plated Nylock nut                               | 8        |
| 9    | 34-545-004     | Chute weldment:   | 1        |
|      | 34-545-005     | BHBD-2-36   | 1        |
|      | 34-545-006     | BHBD-2-48   | 1        |
| 10   | 11105          | <sup>3</sup> / <sub>8</sub> in. – 16 x 1in. HHCS #2 zinc-plated bolt                      | 10       |
| 11   | 33008          | <sup>3</sup> / <sub>8</sub> in. USS zinc-plated flat washer                               | 20       |
| 12   | 37024          | <sup>3</sup> / <sub>8</sub> in. Nylock insert nut   | 10       |
| 13   | 09-516-012     | Mounting block subassembly bracket  | 2        |
| 14   | 13363          | <sup>3</sup> / <sub>4</sub> "-10 x 2 <sup>1</sup> / <sub>2</sub> HHCS #5 zinc-plated bolt | 4        |

**FIG. 7B:** BHBD-4-36, BHBD-4-48, and BHBD-4-60 exploded parts diagram & bill of materials



| Item | Part no.       | Description   | Quantity |
|------|----------------|---|----------|
| 1    | 24-612-003     | Weldment, cylinder pin  | 2        |
| 2    | 34-545-004     | Weldment, chute:<br>BHBD-4-36                                 | 1        |
|      | 34-545-005     | BHBD-4-48   | 1        |
|      | 34-545-00      | BHBD-4-60   | 1        |
| 3    | 34-037-001     | Stop block  | 2        |
| 4    | 34-514-040     | Weldment, frame, base:<br>BHBD-4-36                           | 1        |
|      | 34-514-041     | BHBD-4-48   | 1        |
|      | 34-514-042     | BHBD-4-60   | 1        |
| 5    | 34-514-005     | Retaining tube assembly                                       | 1        |
| 6    | 13365          | $\frac{3}{4}$ "-10UNC x 3", zinc plated #5 bolt               | 4        |
| 7    | 37039          | Nylock nut, zinc plated, $\frac{3}{4}$ "-10                   | 8        |
| 8    | 34-545-024     | Weldment, frame, guard:<br>BHBD-4-36                          | 2        |
|      | 34-545-023     | BHBD-4-48   | 2        |
|      | 34-545-022     | BHBD-4-60   | 2        |
| 9    | 33008          | Flat washer, low carbon, USS, zinc plated, $\frac{3}{8}$ "    | 20       |
| 10   | 11105          | Hex bolt, gr. A, zinc plated, $\frac{3}{8}$ "-16 x 1"         | 10       |
| 11   | 37024          | Nylon insert lock nut, gr. 2, zinc finish, $\frac{3}{8}$ "-16 | 10       |
| 12   | 09-516-012     | Subassembly, bracket, mounting block                          | 2        |
| 13   | 13363          | $\frac{3}{4}$ "-10 x 2" HHCS, #5, zinc plated bolt            | 4        |
| 14   | 99-021-909-001 | Cylinder, 2 $\frac{1}{2}$ in. x 18in.                         | 2        |

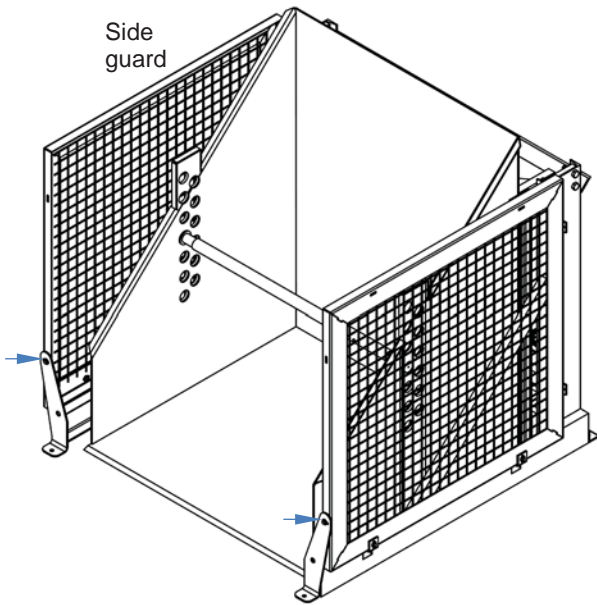
**FIG. 7C:** BHBD-6-36, BHBD-6-48, and BHBD-6-60 exploded parts diagram & bill of materials



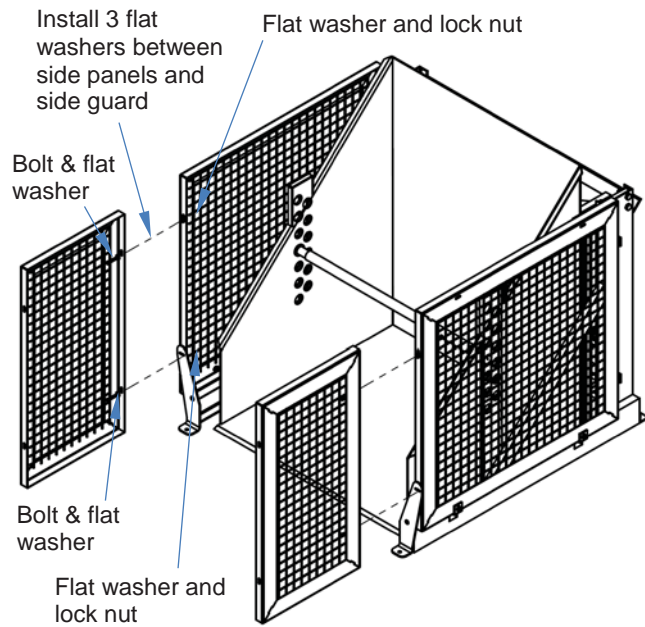
| Item | Part no.   | Description  | Quantity |
|------|------------|--|----------|
| 1    | 34-524-024 | Weldment, frame, guard:<br>BHBD-6-36                             | 2        |
|      | 34-524-023 | BHBD-6-48  | 2        |
|      | 34-524-022 | BHBD-6-60  | 2        |
| 2    | 34-037-001 | Stop block   | 2        |
| 3    | 34-514-005 | Retaining tube assembly  | 1        |
| 4    | 13365      | $\frac{3}{4}$ "-10UNC x 3", zinc plated #5 bolt                  | 4        |
| 5    | 37039      | Nylock nut, zinc plated, $\frac{3}{4}$ "-10                      | 8        |
| 6    | 99-021-947 | Cylinder, hydraulic, 3"x36", piston style with clevis mounts     | 2        |
| 7    | 04-612-011 | Weldment, pin with retaining bracket                             | 4        |
| 8    | 34-514-043 | Weldment, frame, base:<br>BHBD-6-36                              | 1        |
|      | 34-514-039 | BHBD-6-48  | 1        |
|      | 34-514-038 | BHBD-6-60  | 1        |
| 9    | 34-545-019 | Weldment chute:<br>BHBD-6-36                                     | 1        |
|      | 34-545-020 | BHBD-6-48  | 1        |
|      | 34-545-018 | BHBD-6-60  | 1        |
| 10   | 09-516-012 | Subassembly, bracket, mounting block                             | 2        |
| 11   | 33008      | Flat washer, low carbon, USS, zinc plated, $\frac{3}{8}$ "       | 20       |
| 12   | 11105      | Hex bolt, gr. A, zinc plated, $\frac{3}{8}$ "-16 x 1"            | 10       |
| 13   | 37024      | Nylon insert lock nut, gr. 2, zinc finish, $\frac{3}{8}$ "-16    | 10       |
| 14   | 13363      | $\frac{3}{4}$ "-10 x 2 $\frac{1}{2}$ " HHHCS #5 zinc plated bolt | 4        |

## INSTALLING OPTION BHBD-GATE

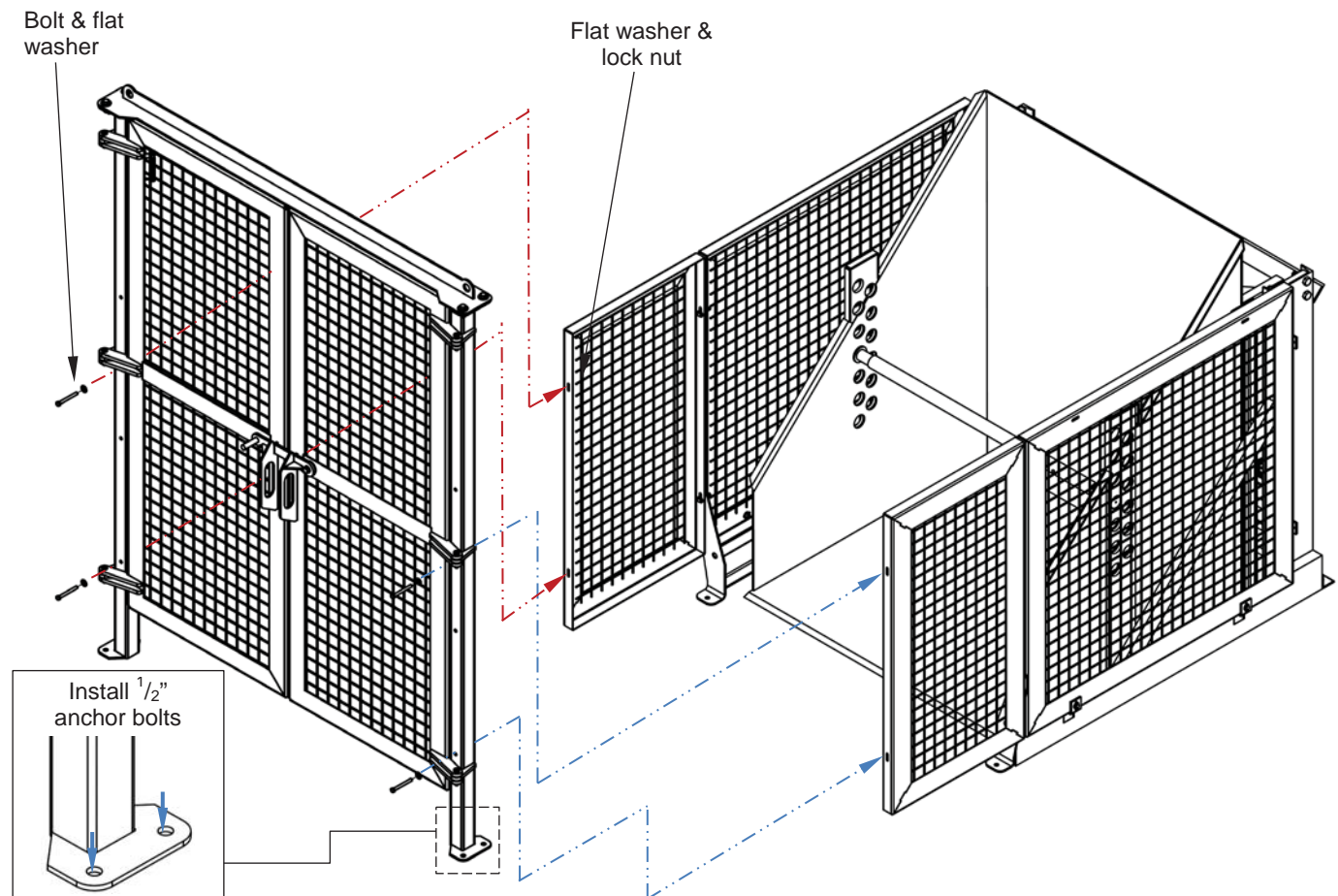
**Step 1:** Remove the bolts, washers, and nuts (arrows in diagram) from the front edge of each side guard.



**Step 2:** Fasten the BHBD-GATE side panels to the front edges of the guards using  $\frac{3}{8}$ "-16 x 2" bolts,  $\frac{3}{8}$ "-16 lock nuts, and  $\frac{3}{8}$ " flat washers as diagrammed below.



**Step 3:** Fasten the door assembly to the side panels with  $\frac{3}{8}$ "-16 x  $3\frac{1}{2}$ " bolts,  $\frac{3}{8}$ "-16 lock nuts, and  $\frac{3}{8}$ " flat washers. Anchor the door assembly to the ground by installing  $\frac{1}{2}$ " anchor bolts of appropriate length through the 2 bolt holes in each foot.





## TROUBLESHOOTING

**⚠ WARNING** DO NOT attempt to resolve any issue discussed below UNTIL the chute is fully lowered and the power supply is disconnected.

| <u>Issue:</u>  | <u>Possible cause(s):</u>   | <u>Solution:</u>  |
|--|---|---|
| 1. Power unit doesn't run when "UP" button is pressed.   | 1a. Transformer fuse is blown.<br>b. No supply voltage.<br><br>c. Upper-travel limit switch is engaged or bad.<br>d. Faulty connection in control circuit.<br>e. Bad control transformer.<br>f. Open motor relay coil.<br>g. (DC units) Low battery voltage.  | 1a. Test with meter; replace if bad.<br>b. Test with meter. Check fuses, breakers, and overloads to determine the cause.<br>c. Inspect and test switch. Replace if bad.<br>d. Test all parts of circuit with meter.<br><br>e. Check for 24 VAC; replace if bad.<br>f. Test with meter; replace if bad.<br>g. Test with meter. Charge battery if low (is motor relay LED on?)  |
| 2. Motor runs properly, chute doesn't move. Motor and pump not noisy.  | 2a. Incorrect motor rotation.<br><br>b. Pump failure.<br>c. Low hydraulic fluid level.  | 2a. Verify motor shaft rotates counterclockwise.<br>b. Consult factory for replacement.<br>c. Ensure reservoir is filled.   |
| 3. Motor or control enclosure hums, chatters, or buzzes, or some type of squeal can be heard; the chute does not move, or the chute moves only slowly. | 3a. See 2b above.<br>b. Excess voltage drop to motor due to power wire size too small, wire run too long, or incoming voltage too low.<br>c. Motor is "single-phasing".<br><br>d. Pressure relief opening at full pressure.<br><br>e. Contamination holding open the lowering valve or the check valve. | 3a. Same as 2b.<br>b. Check power installation for adequacy. Check incoming voltage <i>while motor is running</i> . Correct problem(s).<br>c. Determine cause of loss of voltage on one phase; correct.<br>d. Check for structural damage or binding of the rollers, etc. Check for chute overload condition.<br>e. Remove and inspect. Clean the valve with mineral spirits. |
| 4. Chute elevates, then drifts down.   | 4. See 3e above.  | 4. Same as 3e.  |
| 5. Chute lowers too slowly.  | 5a. Flow control spool is stuck.<br><br>b. Pinched hose.<br><br>c. Velocity fuse locking (chute only slowly creeps down).   | 5a. Remove plug from FC port; push down on the center of the flow spool to ensure it moves freely.<br>b. Check pressure, supply, and return hoses for kinks.<br>c. Same as 7 (below).   |
| 6. Chute lowers too quickly.   | 6a. See 3e.<br>b. Flow control spool is stuck.  | 6a. Same as 3e.<br>b. Same as 5a.   |
| 7. Spongy or jerky chute motion.   | 7. Air in the hydraulic cylinders.  | 7. <b>Bleed air</b> per procedure described on p. 6 of this manual.   |

## LIMITED WARRANTY

Beacon Industries, Inc. (“Beacon”) warrants this product to be free of defects in material and workmanship during the warranty period. Our warranty obligation is to provide a replacement for a defective, original part covered by the warranty after we receive a proper request from the Warrantee (you) for warranty service.

### Who may request service?

Only a warrantee may request service. You are a warrantee if you purchased the product from Beacon or from an authorized distributor AND Beacon has been fully paid.

### Definition of “original part”?

An original part is a part used to make the product as shipped to the Warrantee.

### What is a “proper request”?

A request for warranty service is proper if Beacon receives: 1) a photocopy of the Customer Invoice that displays the shipping date; AND 2) a written request for warranty service including your name and phone number. Send requests by one of the following methods:

|                         |                |  |
|-------------------------|----------------|--|
| <u>US Mail</u>          | <u>Phone:</u>  | <u>Email</u>   |
| Beacon Industries, Inc. | (314) 487-7600 | <a href="mailto:info@beacontechnology.com">info@beacontechnology.com</a> |
| 12300 Old Tesson Rd.    | <u>Fax:</u>    | Enter “Warranty service request”   |
| St. Louis, MO 63128     | (314) 487-0100 | in subject field.  |

In the written request, list the parts believed to be defective and include the address where replacements should be delivered. After Beacon receives your request for warranty service, an authorized representative will contact you to determine whether your claim is covered by the warranty. Before providing warranty service, Beacon will require you to send the entire product, or just the defective part (or parts), to its facility in Angola, IN.

### What is covered under the warranty?

The warranty covers defects in the following original, dynamic parts: motors, hydraulic pumps, motor controllers, and cylinders. It also covers defects in original parts that wear under normal usage conditions (“wearing parts”), such as bearings, hoses, wheels, seals, brushes, and batteries.

### How long is the warranty period?

The warranty period for original dynamic components is 1 year. For wearing parts, the warranty period is 90 days. Both warranty periods begin on the date Beacon ships the product to the Warrantee. If the product was purchased from an authorized distributor, the periods begin when the distributor ships the product. Beacon may, at its sole discretion, extend a warranty period for products shipped from authorized distributors by up to 30 days to account for shipping time.

### If a defective part is covered by the warranty, what will Beacon do to correct the problem?

Beacon will provide an appropriate replacement for any *covered* part. An authorized representative of Beacon will contact you to discuss your claim.

### What is not covered by the warranty?

The Warrantee (you) is responsible for paying labor costs and freight costs to return the product to Beacon for warranty service.

### Events that automatically void this Limited Warranty.

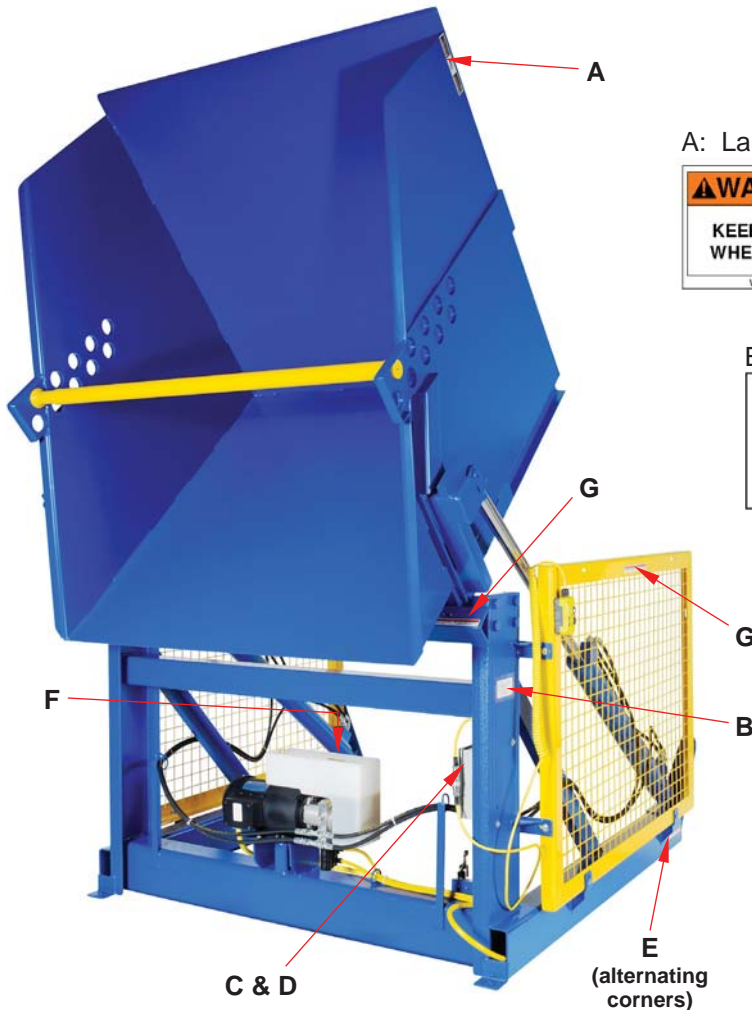
- Misuse;
- Negligent assembly, installation, operation or repair;
- Installation/use in corrosive environments;
- Inadequate or improper maintenance;
- Damage sustained during shipping;
- Collisions or other accidents that damage the product;
- Unauthorized modifications: Do not modify the product IN ANY WAY without first receiving written authorization from Beacon.

### Do any other warranties apply to the product?

Beacon Industries, Inc. makes no other express warranties. All implied warranties are disclaimed to the extent allowed by law. Any implied warranty not disclaimed is limited in scope to the terms of this Limited Warranty. Beacon makes no warranty or representation that this product complies with any state or local design, performance, or safety code or standard. Noncompliance with any such code or standard is not a defect in material or workmanship.

# LABELING DIAGRAM

The unit should be labeled as shown in the diagram. However, label content and location are subject to change so your product might not be labeled exactly as shown. You may request replacement parts and/or service by calling (314) 487-7600 and asking the operator to connect you to the Parts Department.



A: Label #220

|  |  |  |
|--|--|--|
| <b>⚠ WARNING</b>   | <b>⚠ ADVERTENCIA</b>                       | <b>⚠ AVERTISSEMENT</b>                     |
| KEEP CLEAR WHEN IN USE   | MANTENGASE ALEJADO CUANDO SE ESTA OPERANDO | SE TENIR À DISTANCE LORS DU FONCTIONNEMENT |
| VESTIL MANUFACTURING CORPORATION • Angola, Indiana USA • Phone (260) 665-7586 • sales@vestil.com • www.vestil.com 220 Rev 0803 |  |  |

B: Label #287

|   |
|---|
| MODEL/MODÉLO/MODÈLE _____                                     |
| STATIC CAPACITY (evenly distributed) _____ lbs.               |
| LA CAPACIDAD CONSTANTE (distribuida uniformemente) _____ kgs. |
| CAPACITÉ STATIQUE (distribuée régulièrement) _____ kgs.       |
| SERIAL/SERIE/SÉRIE _____                                      |
| 287 REV 0812  |

C: Label #250

|  |             |             |
|--|-------------|-------------|
| <b>NOTICE</b>                                    | <b>NOTA</b> | <b>AVIS</b> |
| POWER SUPPLY: 460V/3 Phase/60 HZ                 |             |             |
| CONTROL VOLTAGE: 24 V AC                         |             |             |
| CORRIENTE: 460V/3 Fase/60 HZ                     |             |             |
| VOLTAJE DE CONTROL: 24 V CA                      |             |             |
| ALIMENTATION DE COURANT: 460V/3 Monophase/ 60 HZ |             |             |
| CONTRÔLER LE VOLTAGE: 24 V AC                    |             |             |
| 250  |             |             |

D: Label #221

|                  |   |              |
|------------------|---|--------------|
| <b>⚠ DANGER</b>  | <b>ELECTRICAL SHOCK</b><br>Shut power off and consult owners manual before working on this equipment.                   | 221 Rev 0111 |
| <b>⚠ PELIGRO</b> | <b>EI GOLPE ELECTRICO</b><br>Corte la corriente consulte el manual de propietario antes de trabajar en este equipo.     |              |
| <b>⚠ DANGER</b>  | <b>CHOC ELECTRIQUE</b><br>Couper le courant et consulter le manuel d'utilisation avant de travailler sur cet équipement |              |

E: Label #204

|                       |                             |                                       |
|-----------------------|-----------------------------|---------------------------------------|
| <b>⚠ WARNING</b>      | <b>⚠ ADVERTENCIA</b>        | <b>⚠ AVERTISSEMENT</b>                |
| SECURE FRAME TO FLOOR | ASEGURE EL BASTIDOR AL PISO | FIXER SOLIDEMENT LE CADRE AU PLANCHER |
| 204 Rev 1118          |                             |                                       |

F: Label #206

|  |  |
|--|--|
| <b>ISO 32 / 150 SUS</b>  |  |
| HYDRAULIC OIL OR NON-SYNTHETIC TRANSMISSION FLUID                        |  |
| ACEITE HIDRAULICO O LIQUIDOS DE TRANSMISION NO SINTETICOS                |  |
| HUILE OU LIQUIDE HYDRAULIQUE NON-SYNTHÉTIQUE                             |  |
| 206 Rev. 1003  |  |
| VESTIL MANUFACTURING CORPORATION • Phone (260) 665-7586 • www.vestil.com |  |

G: Label #208 (on both left and right sides)

|   |                                       |   |
|---|---------------------------------------|---|
| <b>⚠ WARNING</b>  | <b>⚠ ADVERTENCIA</b>                  | <b>⚠ AVERTISSEMENT</b>                    |
| KEEP CLEAR OF PINCH POINT   | MANTENGASE ALEJADO DEL PUNTO DE CORTE | SE TENIR À DISTANCE DU POINT DE PINCEMENT |
| VESTIL MANUFACTURING CORPORATION • Phone (260) 665-7586 • Fax (260) 665-1339 • sales@vestil.com • www.vestil.com 208 Rev 0803 |                                       |   |