

Beacon Industries, Inc.

12300 Old Tesson Rd. • St. Louis, MO 63128-2247 USA
Phone: (314) 487-7600 Fax: (314) 487-0100
www.beacontechnology.com
E-Mail: sales@beacontechnology.com

Revised 10-01

OWNER'S MANUAL

LIFT TILT TABLE SERIES BEHLTT

Contents

Warning and Safety Instructions	1	Periodic Maintenance Instructions	8
Receiving Instructions	1	Trouble Shooting Guide	9-10
Loading Instructions	2	Exploded Parts Drawing	11
Installation Instructions	2	Parts List	12
Operating Instructions	2	Warning Label Identification	13
Electric Schematic	3-4	Material Safety Data Sheets	14-15
Power Conversion	5	Warranty	16
Hydraulic Operation & Schematic	6-7	Service Record	16

WARNINGS & SAFETY INSTRUCTIONS

Read owner's manual completely before operating unit!

- Not a personnel lift. Keep clear when operating
- Never go under platform if there is weight on unit.
- Remove weight before working on unit.
- Use only maintenance parts supplied or approved by the manufacturer.
- Do not change pressure relief valve setting.
- Do not clamp cylinder in vise as you may distort barrel.
- Never operate lift unless you are watching it.
- Load lift as uniformly as possible.
- Consult factory for uneven loading.
- Do not continue to hold down the UP control if unit is not raising.
- Relieve system pressure by holding DOWN button after unit has come to rest.
- Consult factory if adding conveyor top or performing any modification to the original equipment.
- Do not use hydraulic oils, brake fluids or jack oils. Use AW-32 Hydraulic Oil.
- Make sure all operator safety labels are in place.

Remove all packing and strapping material, inspect for damage. IF DAMAGE IS EVIDENT, FILE A CLAIM WITH THE CARRIER IMMEDIATELY! Also, check the unit size, type of power unit, etc., to ensure the unit is correct for the intended application.

MODEL NUMBER AND CAPACITY

The model number, serial number and capacities are inscribed on the nameplate. Please remember to include these numbers in any correspondence with you dealer or the factory.

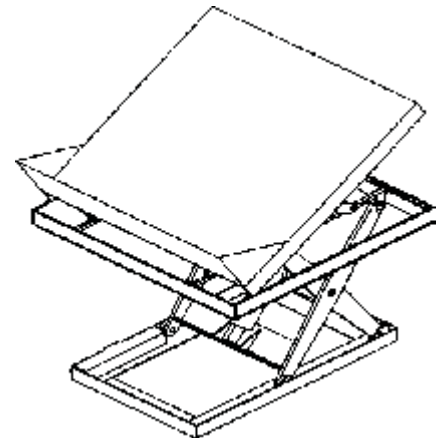

**LIFT TILT TABLE
SERIES BEHLTT**

RECEIVING INSTRUCTIONS

Every unit is thoroughly tested and inspected prior to shipment. However, it is possible that the unit may incur damage during transit. If you see damage when unloading make a note of it on the SHIPPER RECEIVER.

LOADING INSTRUCTIONS

The load capacity rating as inscribed on the nameplate of your unit designates the net capacity, assuming the load is centered. This capacity must never be exceeded, as permanent damage or injury may result.

INSTALLATION TOOLS REQUIRED

A fork truck or some means to lift the table.

An adequately-sized power circuit with the specified voltage, including a disconnecting means with fuses or a circuit breaker. See the electrical section and refer to the NEC and local codes.

INSTALLATION

- Check local codes for requirements pertaining to your application.
- Blow out any hoses that arrive unconnected in order to remove any potential contamination.
- Set the machine in place with a fork truck, crane, etc. (If it is to be pit-mounted, connect power to the table and raise the platform before setting it into the pit.)
- Connect the proper power supply to the table using personnel qualified to work with electricity.
- Raise the platform to its full raised height using the push-button control. Install the maintenance props (one on each side of the frame) and lower the platform using the push-button control until it rests on the maintenance props.
- Anchor the frame to the floor using 1/2" concrete anchors adequate for the floor on which the table is resting. Shim or grout under the frame sides so that the entire length of each frame side is supported.
- Operate the lift through several cycles, verifying that the "platform raised," "platform tilted," and "platform level" limit switches all work properly. Verify the operating of the perimeter pinch point (toe) safety guard.
- Clean up any spilled oil or debris.

SEQUENCE OF OPERATION

This machine is furnished with a constant-pressure, or dead-main, style push-button control. Pressing the "LIFT RAISE" button will turn on the power unit and cause the table to lift straight up. It will continue to move as long as you hold the button or until the lift reaches its maximum raised height. When the button is released, the platform stops and holds at that particular height.

Pressing the "LIFT LOWER" button energizes the lowering solenoid's coil and lowers the platform at a controlled rate of descent. Upon releasing the button, the platform stops and holds at that height.

Pressing the "TILT RAISE" button turns on the power unit and causes the platform to slide in toward the center of the table and tilt at the same time. It will continue to tilt until either the operator releases the button or the platform reaches its maximum tilt angle. When the button is released, the platform stops and holds its position.

Pressing the "TILT LOWER" button also turns on the power unit and causes the platform to tilt down toward the horizontal position until either the button is released or the platform is lowered to the horizontal position.

OPERATOR TIPS

- Read and understand all warning labels on the lift before operating it.
- Stand clear and to the side of the unit when it is moving.
- Don't use the lift if you suspect it is in need of repairs or if it is malfunctioning.
- Notify maintenance personnel in the event that you notice anything out of the ordinary, such as binding, odd pump noises, etc.
- Don't continue to press either of the "LIFT" buttons if the platform doesn't move. Doing so could cause damage to the pump or motor.

ELECTRICAL SCHEMATIC

--- Indicates wire and/or components supplied by others

* ALL COMPONENTS ARE SHOWN AS THEY ARE WITH THE PANEL IN ITS "HOME", OR RESTING, POSITION. HOME POSITION IS DEFINED TO BE WITH THE PLATFORM IS HORIZONTAL (LEVEL WITH) AND LOCKED TO THE FLOOR.

OVERCURRENT & SHORT CIRCUIT PROTECTION, AND DISCONNECT ARE TO BE PROVIDED BY THE END-USER PER THE NEC (NFPA 70) AND LOCAL CODES.

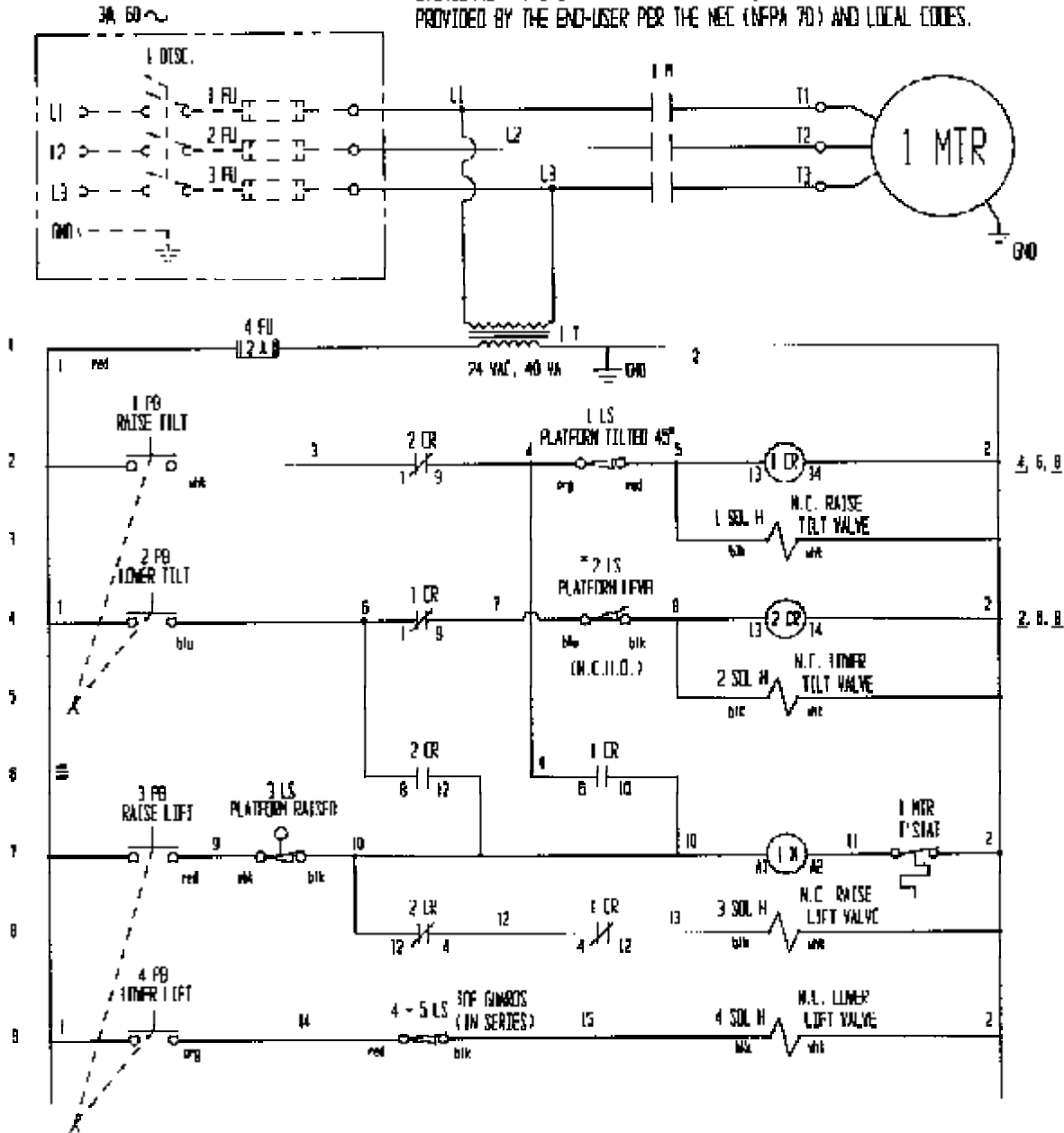

RELAY BASE (TOP VIEW) LAYOUT

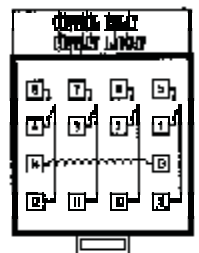

BE SURE ALL POWER IS OFF BEFORE ATTEMPTING TO WORK ON THIS EQUIPMENT?
CAUTION: SERVICE WORK SHOULD BE PERFORMED ONLY BY TRAINED & QUALIFIED PERSONNEL.

PRIMARY WIRING FOR CONTROL TRANSFORMER

208V, 3-PHASE
FUSING AND
DISCONNECT
TO BE PROVIDED
BY OTHERS

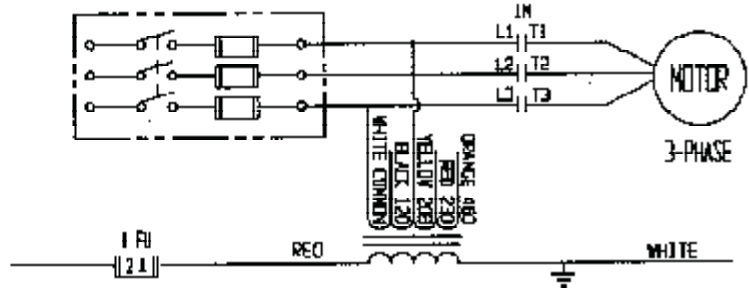

230V, 3-PHASE
FUSING AND
DISCONNECT
TO BE PROVIDED
BY OTHERS

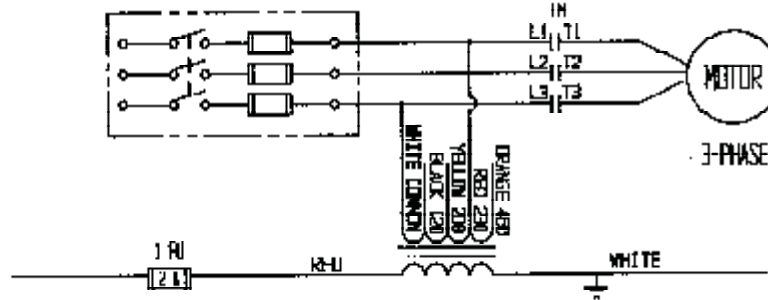

460V, 3-PHASE
FUSING AND
DISCONNECT
TO BE PROVIDED
BY OTHERS

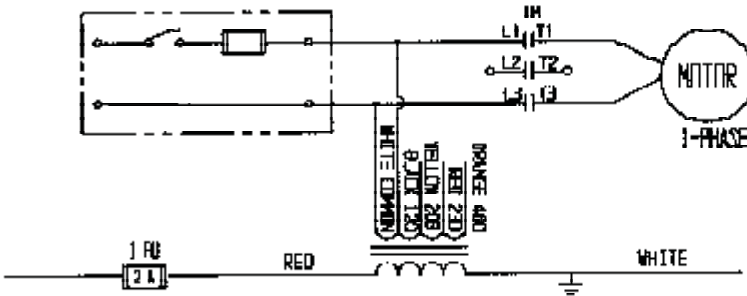
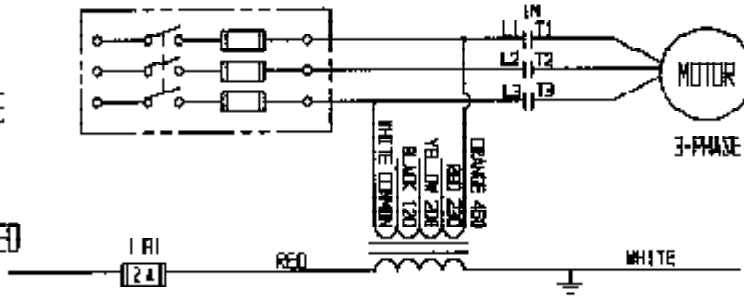

120V, 1-PHASE
FUSING AND
DISCONNECT
TO BE PROVIDED
BY OTHERS

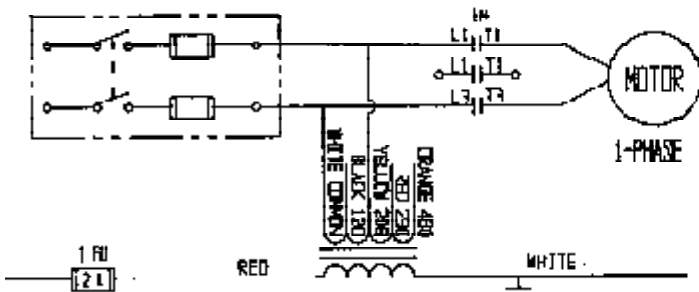

208V, 1-PHASE
FUSING AND
DISCONNECT
TO BE PROVIDED
BY OTHERS

POWER CONVERSION

MOTOR LEAD CONNECTION DIAGRAM FOR ALL
.5HP, .75HP AND 3HP SINGLE-PHASE MOTORS AND FOR
ALL 2HP, 5.5HP, AND 6.5HP THREE-PHASE MOTORS

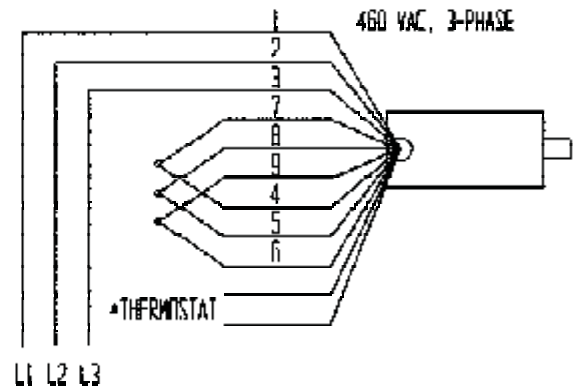
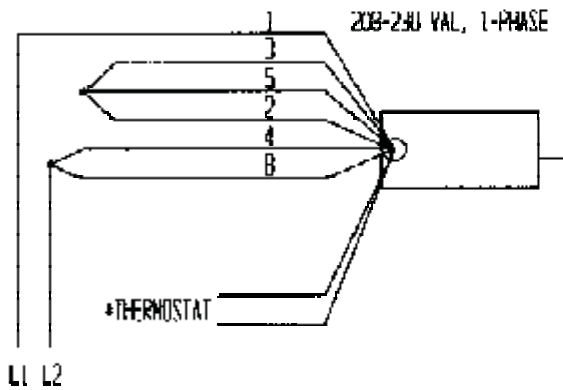
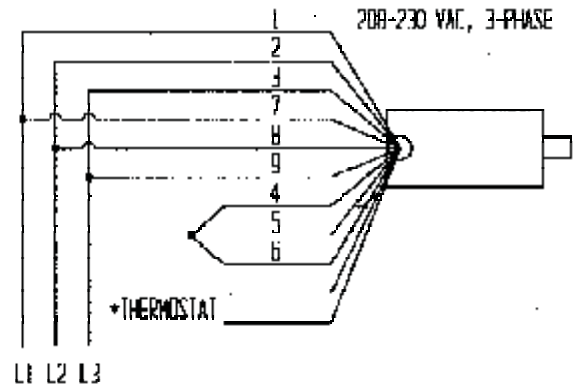
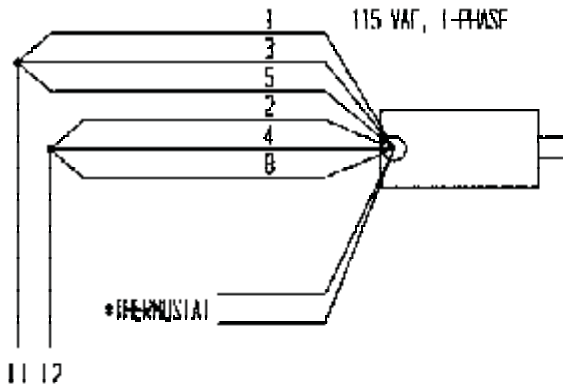

* The two thermostat leads go to: 1) the grounded side of the transformer secondary, and; 2) the motor relay coil, in either order.



BE SURE ALL POWER IS OFF BEFORE ATTEMPTING TO WORK ON THIS EQUIPMENT!

CAUTION: SERVICE WORK SHOULD BE PERFORMED ONLY BY TRAINED & QUALIFIED PERSONNEL

HYDRAULIC OPERATION

To raise the platform, the operator presses the "RAISE LIFT" button on the handheld control. That energizes the electric motor which turns the hydraulic pump. Oil from the reservoir is drawn in through the suction filter and into the pump. The pump then delivers pressurized oil through the "RL" solenoid valve (item 4B) and the check valve (item 5) to the lift cylinder(s).

To lower the platform, the operator presses the "LOWER LIFT" button on the handheld control, which energizes only the "LL/FC" lowering solenoid valve (item 4A). That allows oil from the lift cylinder(s) to pass through a pressure-compensated flow control (item 6) to the reservoir, thereby providing for a smooth, safe platform decent.

The check valve and lowering valve prevent the oil from leaving the cylinder(s) until the "LOWER LIFT" button is pressed, holding the platform when it's stopped anywhere in the mid-range of its travel.

To tilt the platform, the operator presses the button on the handheld control appropriate for the direction the platform is to move. The motor and a directional valve (item 6A or 6B) energizes, allowing oil to pass to the proper port of the tilting cylinder(s). As oil enters the port at one end of the tilt cylinder, it is forced from the opposite port and passes through a counterbalance valve (item 2A or 2B). The counterbalance valves "meter" the flow out of the cylinder to provide smooth motion of the platform as it tilts, and serves as a check valve to hold the platform when it's stopped in the mid-range of its travel.

The valves mentioned above are cartridge type valves, and are virtually maintenance free. In the event a valve needs to be cleaned, raise the platform, flip the maintenance props, and lower the leg set until it engages the props. Remove the electrical coil from the valve, then unscrew the valve from the manifold. Inspect the o-rings and teflon washer on the valve for damage.

Immerse the valve in kerosene or mineral spirits and use a thin object like a small screwdriver to manually operate the valve by pushing in the poppet from the bottom end. Repeat this several times and then blow the valve off. Reinstall the valve, tightening approximately 30 ft-lbs.

VELOCITY FUSE OPERATION

In the event of a catastrophic hose or fitting failure, the velocity fuse inside each lift cylinder (or the blind end of the tilt cylinder) will snap shut and prevent the table from collapsing. Once repairs have been made to the system the pressure is reapplied to the cylinder(s), the velocity fuse opens up again to allow flow out of the cylinder.

Always bleed the lift cylinders whenever the hydraulic system has been opened. Air in the system can also cause nuisance operation of the velocity fuse.

AIR BLEED PROCEDURE

Air in the hydraulic system can cause a very "spongy" or jerky motion of the platform, and can cause nuisance operation of the cylinders' internal velocity fuse.

If the cylinder(s) need to be bled of air:

- Locate the "bleeder" screw at the top (blind end) of each lift cylinder
- Take the load off the platform
- Raise the platform and flip the maintenance props to the inside of the frame
- Place a rag or towel over the bleeder screw to catch any oil that sputters out
- Loosen the bleeder screw slowly until air sputters from the fitting
- When clear fluid comes out without any further air sputtering, tighten the bleeder screw
- Flip the maintenance props to the outside of the frame
- Lower the platform and observe for any jerkiness

HYDRAULIC SCHEMATIC

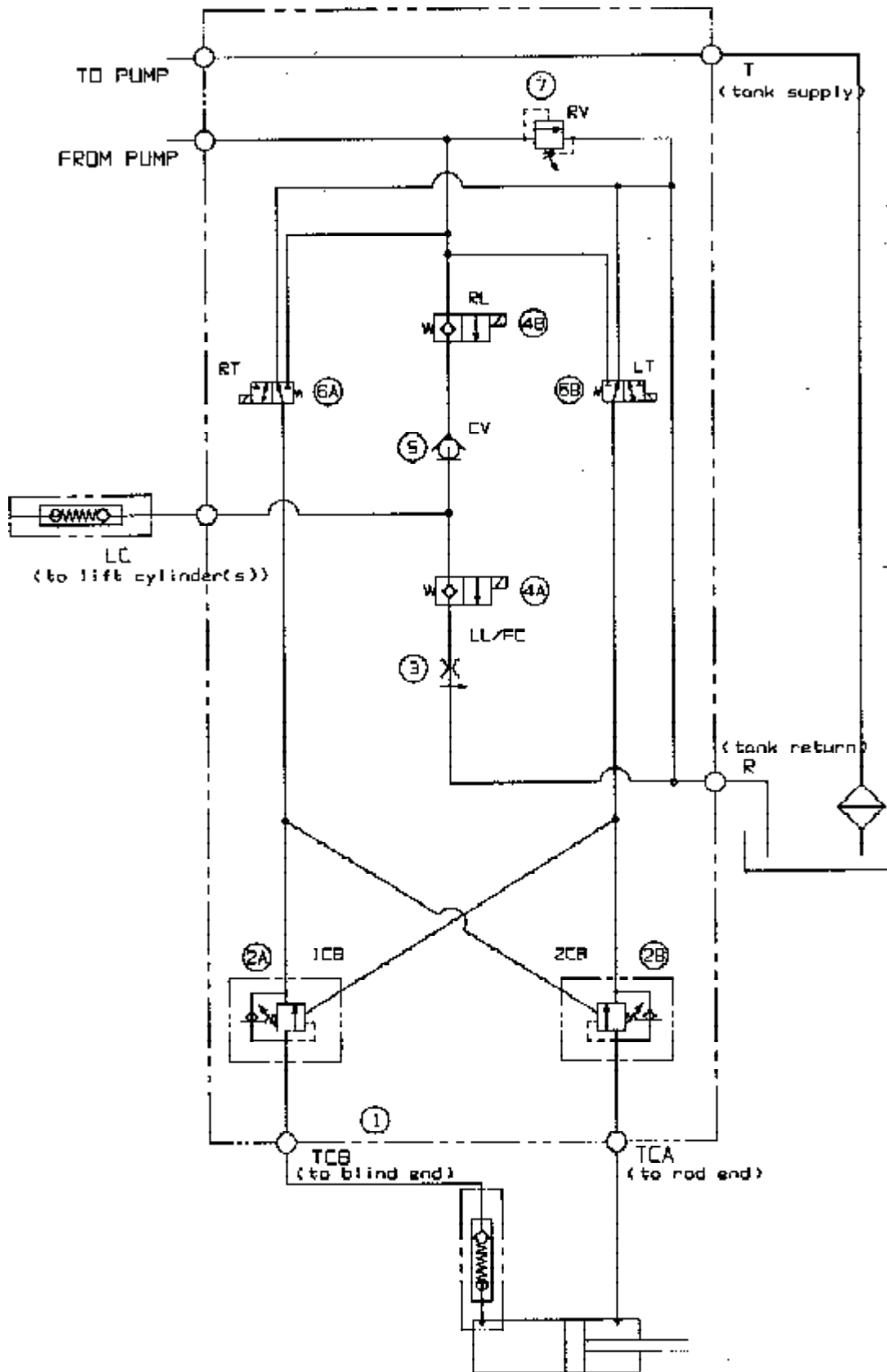

CHECK OIL LEVEL BEFORE TROUBLESHOOTING SCHEMATIC

Routine Maintenance & Safety

Raise the table and install the maintenance safety bars before beginning any inspection or work on the unit (BEHLTT series).

(A) Monthly Inspections

- 1.) Check oil level. Add as necessary.
- 2.) Check for oil leaks. See trouble shooting Section and correct as necessary.
- 3.) Check roller bushings, axle pin, clevis and pivot points for wear.
- 4.) Check for worn or damaged hydraulic hoses or electrical cords.
Repair as necessary.
- 5.) Check rollers for looseness and wear. See trouble shooting.
- 6.) Check retaining rings at all axles, pivot points and clevis.
- 7.) Check for unusual noise. See trouble shooting section.

(B) Yearly Inspection

Oil reservoir should be cleaned and the fluid changed at least once a year, or sooner if the oil darkens or becomes gritty. Presence of water is indicated if the oil turns milky. Recommended oil: AW-32 or H0150 hydraulic fluid, or Dextron transmission fluid.

PERIODIC MAINTENANCE INSTRUCTIONS

Before Each Use

Visual Check for the Following:

Frayed wires

Oil leaks

Pinched or chafed hoses, loose fittings

Structural deformation of platform or frame

Unusual noise or binding

DO NOT USE IF THERE ARE ANY OF THE ABOVE!

Monthly

Check Oil (More frequently for high use application)

Check snap rings

Verify warning labels are in place and in good condition

Check for signs of worn or loose wires

Clean off dirt and debris

Check for floor anchor security

Yearly

Change Oil. More frequently if color is substantially darkened or feels gritty or sticky.

If color is milky, there is water in the oil and it should be changed.

Check bushings for wear, replace if necessary.

All maintenance work must be done by qualified personnel with training in reading schematics and working on electric hydraulic equipment.

TROUBLESHOOTING GUIDE FOR HYDRAULIC EQUIPMENT

BEFORE PREFORMING ANY MAINTENANCE WORK ALWAYS INSTALL MAINTENANCE SAFETY BLOCKS

Observation	Possible Cause	Remedy
1.) Table does not raise but motor is running or humming.	<ul style="list-style-type: none">a. Motor may be single-phasing (humming) if three phase unit.b. Voltage at motor terminals may be too low to run pump at existing load.c. Hose or hydraulic line is leaking.d. Fluid level in reservoir is low.e. Load exceeds capacity requirements. Relief valve is bypassing the fluid back into the reservoir.f. Suction filter is clogged, starving pump.g. Suction line may be leaking air, due to loose fittings.h. Filler/Breather cap on tank may be clogged.i. Down Valve may be energized by faulty wiring or stuck open.j. Hydraulic pump may be inoperative.	<ul style="list-style-type: none">a. Ascertain that all 3 phase lines are present at the motor.b. Measure voltage at motor terminals or as near as possible, while pump is running under load. If voltage is sufficient, check for inadequate or incorrect wiring as this can starve the motor. Correct as necessary.c. Correct as necessary.d. Add fluid. Refer to Owner's Manual for proper fluid levels.e. DO NOT CHANGE RELIEF VALVE SETTING. Instead, reduce the load to rated capacity.f. Remove and clean.g. Inspect all fittings for proper fit.h. Remove and clean.i. Remove Solenoid Valve. Check and clean. (Refer to Hydraulic Section of Owner's Manual).j. Disconnect hydraulic line at power unit. Put pressure line in a large container and cycle pump. If no output, check the pump motor coupling, which may be defective, and correct as necessary. If pump is worn, consult factory for replacement parts service.
2.) Table raises too slowly.	<ul style="list-style-type: none">a. Foreign material stuck in Down Solenoid, causing some fluid to bypass back into tank.b. Foreign material clogging suction filter, breather cap, or a pinched hose.c. Low motor voltage.d. Table overloaded.e. Pump is inoperative.	<ul style="list-style-type: none">a. Lower the platform onto its maintenance props. Remove the solenoid valve and clean. (Refer to Hydraulic Section of Owner's Manual).b. Correct as necessary. (See also, 1(f), (h)).c. See 1(b).d. See 1(e).e. See 1(j).
3.) Motor labors, or is excessively hot.	<ul style="list-style-type: none">a. Voltage may be low.b. Incorrect wiring, or single-phasing.c. Oil starvation causes pump to bind. High internal heat is developed. If this occurs, pump may be permanently damaged.d. Binding cylinders.	<ul style="list-style-type: none">a. See 1(b).b. Check that one leg of the motor lines is not connected to ground. Check motor leads for proper connection for the voltage being supplied; 1(a).c. See 1(d), (f), (g), (h), (j).d. Align cylinders correctly.
4.) "Spongy" or "jerky" table operation. Do not confuse spongy operation with small surges caused by foreign material on the roller tracks.	<ul style="list-style-type: none">a. Fluid starvation.b. Air in system.	<ul style="list-style-type: none">a. See 1(d), (f), (g), (j).b. See air bleed procedure p.9.
5.) Table lowers too slowly when loaded.	<ul style="list-style-type: none">a. Down valve filter clogged.b. Pinched tube or hose.c. Foreign material in flow control valve.d. Binding cylinderse. Foreign material in velocity fuse.	<ul style="list-style-type: none">a. Remove Solenoid Valve and clean filter.b. Correct as necessary. (In case of pipe, check for obstruction in line.)c. Remove and clean Flow Control Valve. (Refer to Hydraulic Section of Owner's Manual).d. Align cylinders correctly.e. Remove and clean Velocity Fuse. (Refer to Hydraulic Section of Owner's Manual.)

Observation

Possible Cause

Remedy

6.) Table lowers too quickly.

- a. Leaking hoses and/or cracked fittings.
 - b. Check valve is stuck open. (The combination of a stuck check valve and open solenoid valve will cause excessive speeds.)
 - c. Foreign material stuck in flow control valve. (In this case, table lowers initially at a normal rate then speeds up as the platform descends.)
- a. Correct as necessary.
 - b. Remove and clean check valve. (Refer to Hydraulic Section of Owner's Manual).
 - c. Remove flow control valve from the valve block and clean. (Refer to Hydraulic Section of Owner's Manual).

7.) Table raises then lowers slowly.

- a. Down solenoid valve may be incorrectly wired or is stuck open due to dirt.
 - b. Check Valve may be stuck open.
 - c. Check for leaking hoses, fittings, pipes.
 - d. Cylinder packing may be worn or damaged.
- a. See 2(a).
 - b. Remove and clean check valve. (Refer to Hydraulic Section of Owner's Manual).
 - c. Correct as necessary.
 - d. Replace packing. (Consult Factory for replacement parts.)

8.) Table has raised, but does not lower.

- a. Blown electrical fuse.
 - b. Incorrect down solenoid valve wiring.
 - c. Down solenoid valve is stuck.
 - d. Faulty down solenoid coil.
 - e. Maintenance safety bar, or some other object blocking down travel.
 - f. Binding cylinders.
 - g. In case of excessive lowering speeds, the velocity fuse will become operative and shut off the oil flow from the cylinders, thus the platform will remain stationary.
 - h. Check if the limit switch is inoperative and the platform has raised all the way so that the cylinders are fully extended. If the cylinder(s) are stroked out, the velocity fuse has been locked up
- a. Check and replace.
 - b. Correct as necessary. (Refer to Electrical Section of Owner's Manual.)
 - c. Lightly tap down the solenoid coil body to seat it properly. (DO NOT hit coil hard as it will permanently damage the internal stem). DO NOT remove the solenoid valve from the block as the unit will come down at a dangerous speed.
 - d. Remove and replace. (Refer to Electrical Section of Owner's Manual.)
 - e. Raise table and remove the safety bar, or whatever object is blocking the down travel.
 - f. See 2(e).
 - g. To unlock, repressurize the hydraulic system by joggling the motor.
 - h. Refer to velocity fuse section of the owner's manual

NOTES

EXPLODED PARTS DRAWING
LIFT & TILT SCISSOR TABLE • SERIES BEHLTT

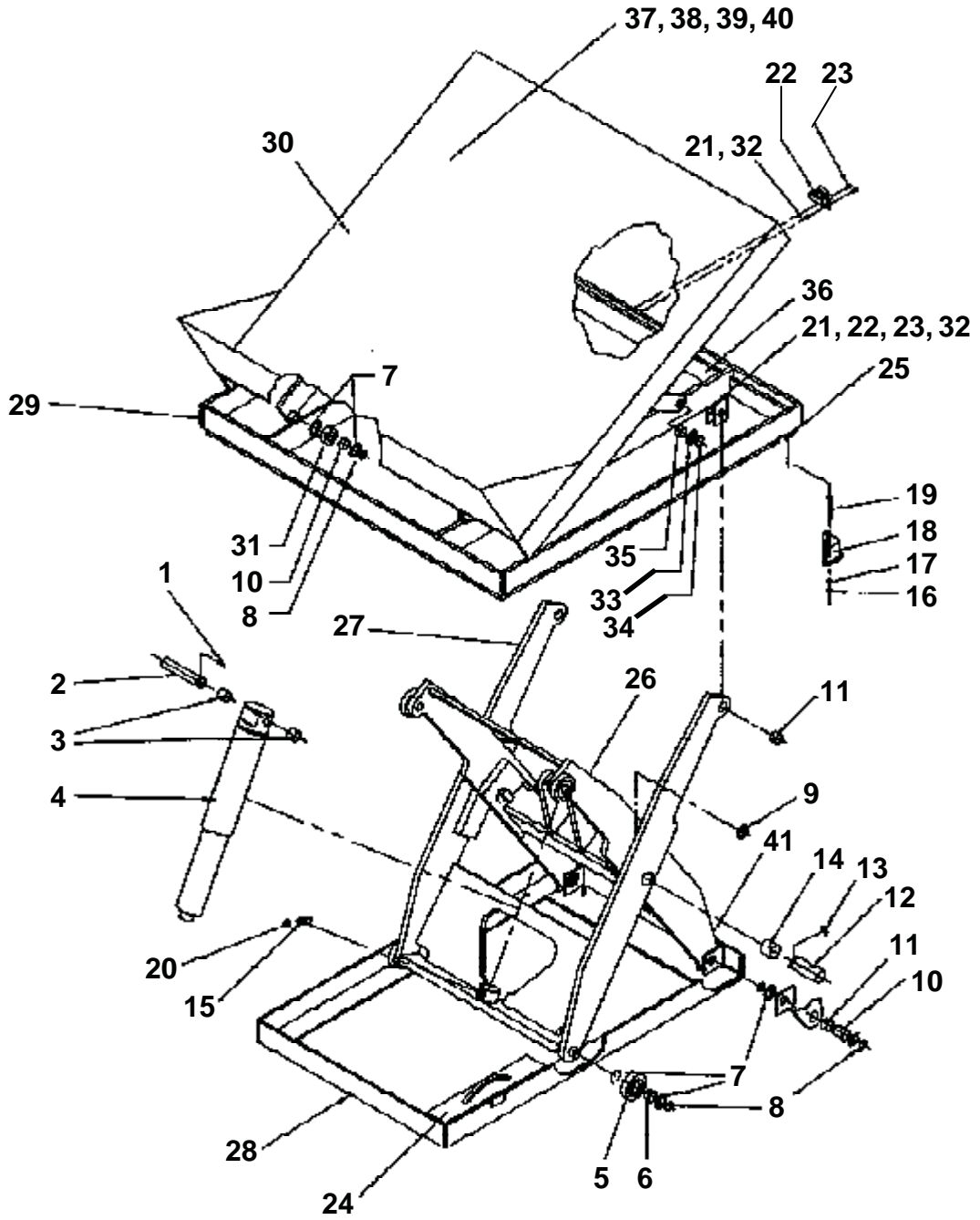

PARTS IDENTIFICATION

LIFT TILT TABLE • SERIES BEHLTT

ITEM NO.	DESCRIPTION	PART NO.	QTY
1	Cylinder Mount Spring Pin	BST-SPRGPIN	1
2	Cylinder Mount Pivot Pin	BST-CYLPIN	1
3	Cylinder Mount Bearing	BST-CYLBRG	2
4	Hydraulic Cylinder	BST-CYL	1
4A	Cylinder Seal Kit (Not Pictured)	BST-CYLSKIT	1
5	Roller	BST-RLR	4
6	Roller Bearing	BST-RLRBRG	4
7	Roller Washer	BST-RLRWSHR	20
8	Roller Snap Ring	BST-RLRSNRG	14
9	Pivot Pin Washer	BST-PVTWSHR	2
10	Hinge Pin	BST-HNGPIN	4
11	Hinge Pin Bearing	BST-HNGBRG	6
12	Pivot Pin	BST-PVTPIN	2
13	Pivot Pin Spring Pin	BST-PVTPSPRP	2
14	Pivot Pin Bearing	BST-PVTBRG	2
15	Cylinder Retainer Bolt	BST-CYLRTBLT	1
16	Toe Guard Hanger Nut	BST-HNGRNUT	4
17	Toe Guard Hanger Washer	BST-HNGRWSH	4
18	Toe Guard Corner Piece	BST-TGRDCNR	4
19	Toe Guard Hanger Screw	BST-HNGRSCR	4
20	Cylinder Retainer Bolt Nut	BST-CYLRTBLTN	1
21	Toe Guard Switch Retaining Nut	BST-TGRDNUT	6
22	Toe Guard Switch	BST-TGRDSW	3
23	Toe Guard Switch Retaining Screw	BST-TGRDSCR	6
24	Safety Stop Block	BST-STBLK	1
25	Toe Guard Aluminum Rail	BST-TGRDRAIL	4
26	Inner Leg Assembly	BST-ILEGA	1
27	Outer Leg Assembly	BST-OLEGA	1
28	Frame Assembly	BST-FRA	1
29	Sub-deck Assembly	BST-SDA	1
30	Tilt Deck Assembly	BST-TDA	1
31	Tilt Table Roller	BSTT-TLTRLR	2
32	Toe Guard Switch Flat Washer (Not Shown)	BSTT-TGRDSFWSHR	6
33	Control Link Washer	BSTT-LNKWSHR	8
34	Control Link Snap Ring	BSTT-LNKSRNG	4
35	Control Link Bearing	BSTT-LINKBRG	4
36	Control Link	BSTT-LINK	2
37	Tilt Table Cylinder (Not Shown)	BSTT-TLTCYL	1
38	Tilt Table Cylinder Clevis Pin (Not Shown)	BSTT-TLTCYLCLPN	2
39	Tilt Table Cylinder Cotter Pin (Not Shown)	BSTT-TLTCYLCOPN	2
40	Tilt Table Hydraulic Hose Kit (Not Shown)	BSTT-TLTCYLHSK	1
41	Upper Level Limit Switch (Not Shown)	BST-UPLLS	1

WARNING LABEL IDENTIFICATION

MAKE SURE ALL WARNING LABELS ARE IN PLACE!

NOTE:

Labels 1 & 7 are located on junction box cover

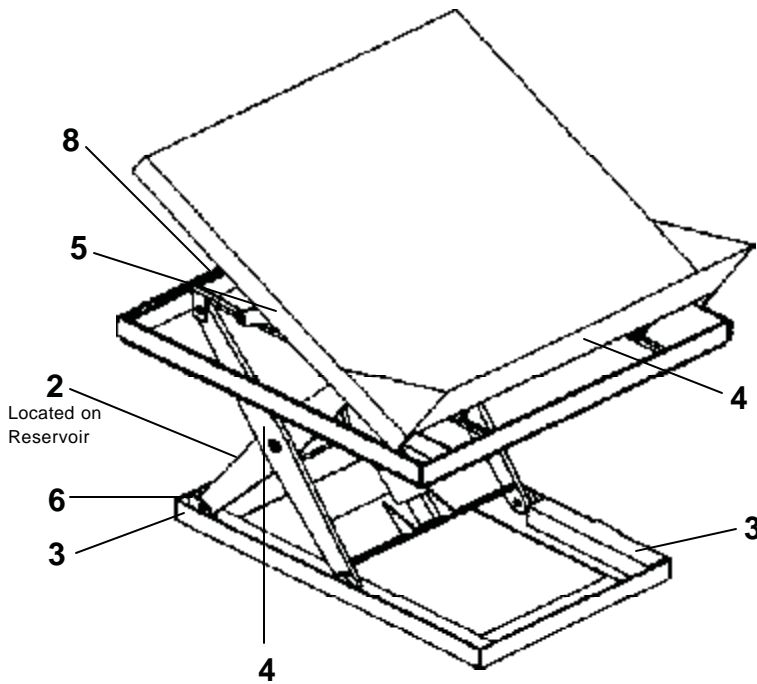

①

NOTICE	NOTA	AVIS
POWER SUPPLY: 115 Volt/1 Phase/60 HZ		
CONTROL VOLTAGE: 24 VOLT AC		
CORRIENTE: 115 Volt/1 Fase/60 HZ		
VOLTAJE DE CONTROL: 24 VOLT CA		
ALIMENTATION ÉLECTRIQUE: 115 Volt/1 Phase/ 60 HZ		
VOLTAGE DE CONTRÔLE: 24 VOLT AC		

248

② ON HYDRAULIC TANK (NOT SHOWN)

ISO AW-32
HYDRAULIC OIL OR EQUIVALENT
ACEITE HIDRÁULICO O EQUIVALENTE
HYDRAULIQUE OU ÉQUIVALENT

206

*Product safety signs or labels should be periodically inspected and cleaned by the product users as necessary to maintain good legibility for safe viewing distance . . . ANSI 535.4 (10.21)
Contact manufacturer for replacement labels if needed.

③

⚠ WARNING	⚠ AVISO	⚠ AVERTISSEMENT
SECURE FRAME TO FLOOR	ASEGURE EL BASTIDOR AL PISO	FIXER SOLIDEMENT LE CADRE AU PLANCHER

204

④

⚠ WARNING	⚠ AVISO	⚠ AVERTISSEMENT
KEEP CLEAR WHEN IN USE	MANTENGASE ALEJADO CUANDO SE ESTA OPERANDO	SE TENIR À DISTANCE LORS DU FONCTIONNEMENT

220

⑦

DANGER ⚠	SHUT POWER OFF AND CONSULT OWNERS MANUAL BEFORE WORKING ON THIS EQUIPMENT
PELIGRO ⚠	CORTE LA CORRIENTE Y CONSULTE EL MANUAL DEL PROPIETARIO ANTES DE OPERAR O REPARAR EL ELEVADOR DE TIJERAS
DANGER ⚠	COUPER LE COURANT ET CONSULTER LE MANUEL D'UTILISATION AVANT DE TRAVAILLER SUR CET ÉQUIPEMENT

221

⑤ BOTH SIDES & FRONT END

⚠ WARNING	⚠ AVISO	⚠ AVERTISSEMENT
KEEP CLEAR OF PINCH POINT	MANTENGASE ALEJADO DE PUNTO DE CORTE	SE TENIR À DISTANCE DU POINT DE PINCEMENT

208

⑥

FOR USER INSTRUCTIONS OR QUESTIONS CONTACT
PARA INSTRUCCIONES DE USO Ó CONSULTAS CONTACTAR
POUR INSTRUCTIONS OU QUESTIONS SUPPLÉMENTAIRES CONTACTER

205

⑧

⚠ DANGER	TO AVOID PERSONAL INJURY READ OWNER'S MANUAL BEFORE OPERATING OR REPAIRING SCISSOR LIFT		DO NOT PUT HANDS, FEET OR OBJECTS UNDER TOP. LOWER PLATFORM SLOWLY.		DO NOT WORK UNDER LIFT WITHOUT SAFETY BLOCK OR WHILE LOADED. KEEP CLEAR OF MOVING SCISSOR LEG MECHANISM.		DO NOT STAND, SIT OR RIDE ON LIFT
⚠ PELIGRO	PARA EVITAR DAÑOS PERSONALES LEA EL MANUAL DEL PROPIETARIO ANTES DE OPERAR O REPARAR EL ELEVADOR DE TIJERAS		NO PONGA MANOS, PIES U OBJETOS DEBAJO DEL BORDE. DESCENDA LA PLATAFORMA LENTAMENTE.		NO TRABAJE DEBAJO DEL ELEVADOR SIN LOS FRENOS DE SEGURIDAD O CUANDO ESTÉ CARGADO. MANTENGASE ALEJADO DEL MECANISMO DE TIJERA EN MOVIMIENTO.		NO SE SIENTE, SE PARE, O VIAJE EN EL ELEVADOR
⚠ ATTENTION	POUR ÉVITER TOUTE BLESSURE PERSONNELLE LIRE LE MANUEL D'UTILISATION AVANT DE METTRE EN MARCHÉ OU AVANT DE RÉPARER L'ÉLEVATEUR CISEAU		NE PAS METTRE LES MAINS, LES PIEDS OU TOUT OBJET SOUS LE PLATEAU SUPÉRIEUR. DESCENDRE LA PLAT-FORM LENTEMENT		NE PAS TRAVAILLER SOUS L'ÉLEVATEUR SANS BLOCS DE SÉCURITÉ OU LORSQU' IL EST CHARGÉ. RESTER À L'ÉCART DU MÉCANISME CISEAU LORSQUE L'ÉLEVATEUR EST EN FONCTIONNEMENT.		NE PAS SE TENIR DEBOUT, S'ASSEOIR OU MONTER SUR L'ÉLEVATEUR

207

LIMITED WARRANTY

ONE YEAR LIMITED WARRANTY. The manufacturer warrants for the original purchaser against defects in materials and workmanship under normal use one year after date of purchase. (Not to exceed 15 months after date of manufacture.) Any part which is determined by the manufacturer to be defective in material or workmanship and returned to the factory, shipping costs prepaid, will be, as the exclusive remedy, repaired or replaced at our option. Labor costs for warranty repairs and/or modifications are not covered unless done at manufacturer's facilities. Any modifications performed without written approval of the manufacturer may void warranty. This limited warranty gives purchaser specific legal rights which vary from state to state.

LIMITATION OF LIABILITY. To the extent allowable under applicable law, the manufacturer's liability for consequential and incidental damages is expressly disclaimed. The manufacturer's liability in any event is limited to, and shall not exceed, the purchase price paid. Misuse or modification may void warranty.

WARRANTY DISCLAIMER. Our company has made a diligent effort to illustrate and describe the products shown accurately; however, such illustrations and descriptions are for the sole purpose of identification, and do not express or imply a warranty that the products are merchantable, or fit for a particular purpose, or that the products will necessarily conform to the illustrations or descriptions.

The provisions of the warranty shall be construed and enforced in accordance with the UNIFORM COMMERCIAL CODE and laws as enacted in the State of Indiana.

DISPOSITION. Our company will make a good faith effort for prompt correction or other adjustment with respect to any product which proves to be defective within the Limited Warranty. Warranty claims must be made in writing within said year.

SERVICE RECORD

DATE OF SERVICE: ____/____/____
WORK DONE BY: _____
SERVICE PERFORMED: _____

DATE OF SERVICE: ____/____/____
WORK DONE BY: _____
SERVICE PERFORMED: _____

DATE OF SERVICE: ____/____/____
WORK DONE BY: _____
SERVICE PERFORMED: _____

DATE OF SERVICE: ____/____/____
WORK DONE BY: _____
SERVICE PERFORMED: _____

DATE OF SERVICE: ____/____/____
WORK DONE BY: _____
SERVICE PERFORMED: _____

DATE OF SERVICE: ____/____/____
WORK DONE BY: _____
SERVICE PERFORMED: _____

