

✓ Proven Reliability

✓ Industrial Components

✓ Solid Steel Construction

TILT MASTER

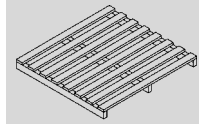

Use with Open Bottom Pallets or Skids

AC • 12V DC • AIR/OIL

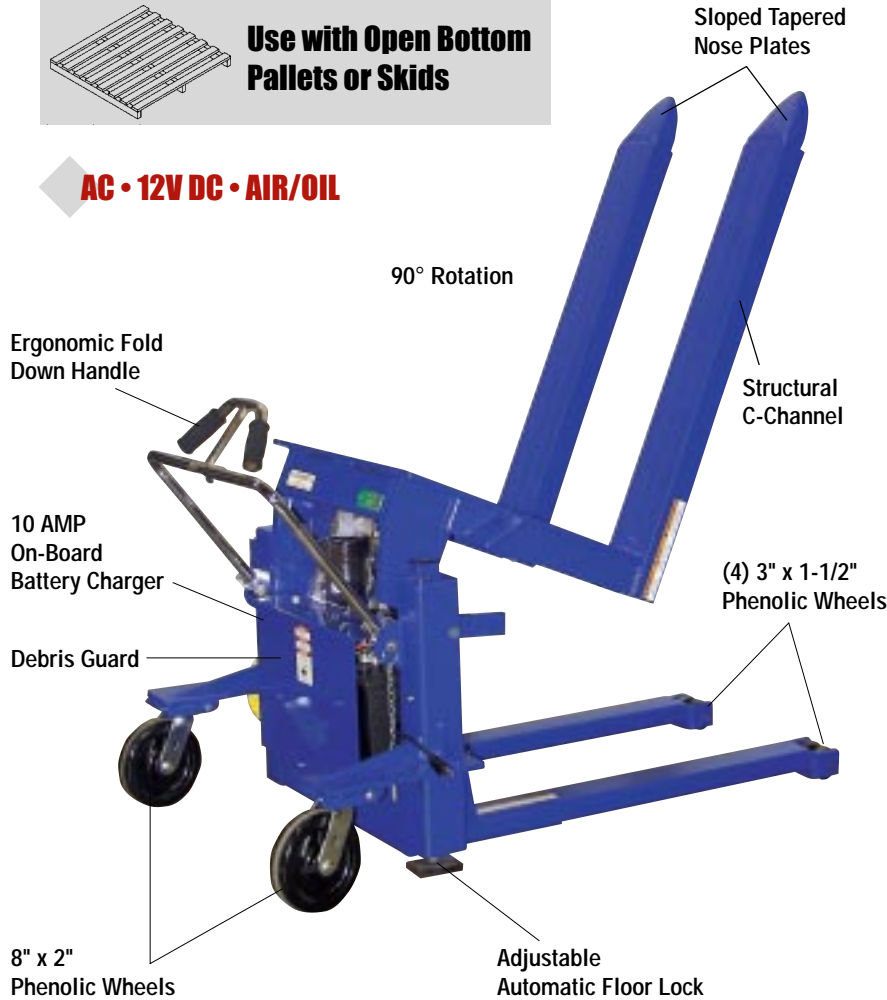

Models BTM-20 • BTM-40 • BTM-60

Lift and position filled tote boxes or baskets without the need of a fork truck or lift table using the newly designed heavy-duty **Tilt Master**. This unit will function as a transporter by moving completed products from work station to work station without waiting for a fork truck. A newly designed folding ergonomic handle has dual steering grips for quick and easy maneuverability. Unit has a thin profile to allow the user to get as close to the load as possible. These units are equipped with an automatic adjustable floor lock. As soon as the forks raise to 20° the adjustable floor lock engages. **Tilt Master** units tilt up to 90° and are to be used with open bottom pallets or skids.



DC OPERATION STANDARD

- On-Board 10 AMP Battery Charger
- Large 8" x 2" Phenolic Steering Wheels
- Exclusive Adjustable Automatic Floor Lock
- Emergency Stop Velocity Fuse in Cylinder
- Fully Enclosed Sloped & Tapered Nose Plate Casting
- Choose AC, 12V DC or AIR/OIL Operation
- Available in Straddle (BTMS)/ Non-Straddle (BTM)

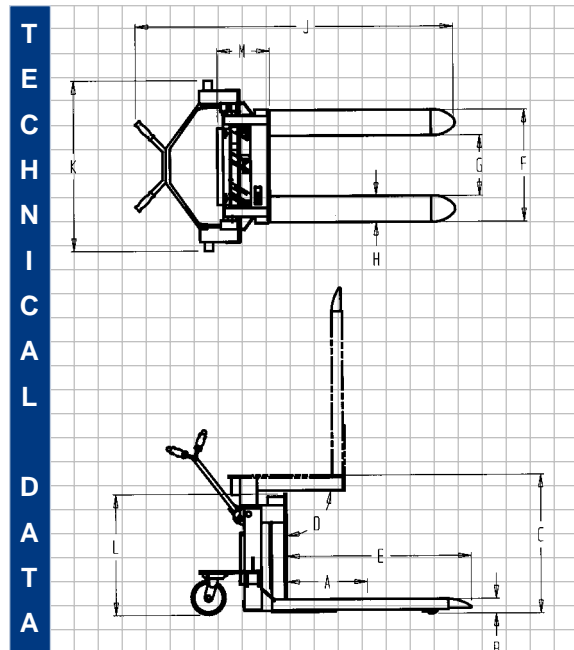

SPECIFICATIONS	BTM-20	BTM-40	BTM-60
Capacity (lbs.)	2,000	4,000	6,000
A Load Center	20"	20"	20"
B Lowered Height	3-1/2"	3-1/2"	3-1/2"
C Lift Height	35"	35"	35"
D Tilt Angle	90°	90°	90°
Usable Fork Length	38"	38"	38"
E Overall Fork Length	43-1/2"	43-1/2"	43-1/2"
F Outer Fork Dimensions	27"	27"	28"
G Inner Fork Dimensions	14"	14"	13"
H Fork Width	6"	6"	7"
J Overall Length	60"	60"	60"
K Width / Including Wheels	35"	35"	35"
L Height	36-1/2"	36-1/2"	36-1/2"
M Reach	14"	14"	16"

TILT MASTER STRADDLE

AC • 12V DC • AIR/OIL

21" Reach

4" Wide Forks

Inside Straddle 49"

8" Wheels (front and rear)

DC Operation Standard

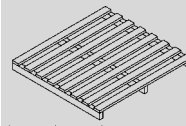

Use with Open or Closed Bottom Pallets or Skids

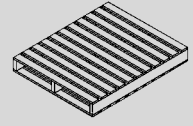

Models BTMS-20 • BTMS-40

Tilt and position loads without the need of a fork truck or lift table with the **Tilt Master Straddle**. Tilts up to 90° and features adjustable forks, 1/2" to 26-1/2" (I.D.), to accommodate different size pallets and skids.



Shown with Optional Power Traction Drive System

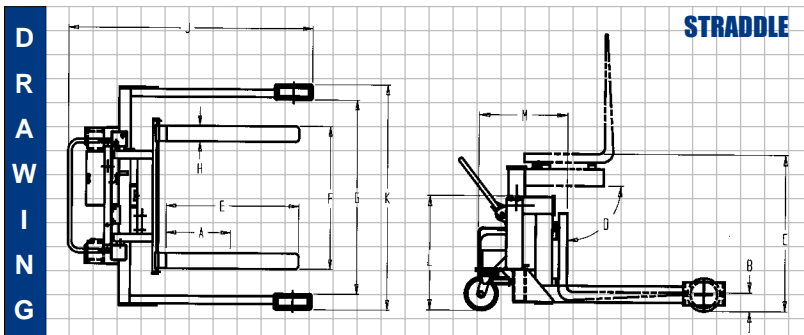

SPECIFICATIONS	BTMS-20	BTMS-40	BTMS-60
Capacity (lbs.)	2,000	4,000	6,000
A Load Center	17"	17"	17"
B Lowered Height	2-5/8"	2-5/8"	2-5/8"
C Lift Height	37-7/16"	37-7/16"	37-7/16"
D Tilt Angle	90°	90°	90°
E Fork Length	36"	36"	36"
F Maximum Fork Width	37"	37"	37"
G Inner Straddle Width	49"	49"	49"
H Fork Width	4"	4"	4"
J Overall Length	72"	72"	72"
K Overall Width	58-3/8"	58-3/8"	58-3/8"
L Height	36-7/16"	36-7/16"	36-7/16"
M Reach	21"	21"	21"

REDUCED REACH TILT MASTER STRADDLE

AC • 12V DC • AIR/OIL

COMPACT FOR INCREASED PRODUCTIVITY

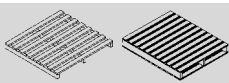

Use with Open or Closed Bottom Pallets or Skids

Models BTMS-RR-20 • BTMS-RR-40

SPECIFICATIONS	BTMS-RR-20	BTMS-RR-40
Capacity (lbs.)	2,000	4,000
A Load Center	17"	17"
B Lowered Height	2-5/8"	2-5/8"
C Lift Height	32-1/2"	32-1/2"
D Tilt Angle	90°	90°
E Fork Length	36"	36"
F Maximum Fork Width	37"	37"
G Inner Straddle Width	49"	49"
H Fork Width	4"	4"
J Overall Length	72"	72"
K Overall Width	58-3/8"	58-3/8"
L Height	36-7/16"	36-7/16"
M Reach	14"	14"

Reduced Reach Tilt Master Straddle will minimize bending and stretching. Reduce the potential of back injuries associated with loading and unloading wire baskets, gaylord containers and corrugated palletized boxes. Reduced reach design is ideal for low height containers and small parts at the bottom of containers.

DC Operation Standard

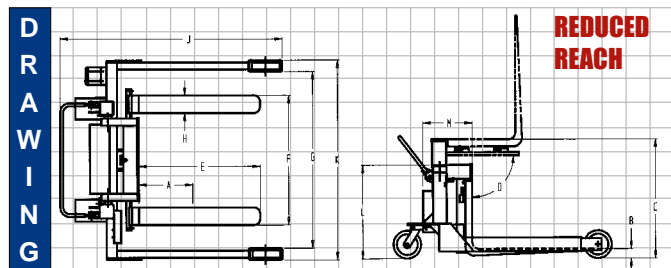

Beacon Industries, Inc.

12300 Old Tesson Rd.

St. Louis, MO 63128-2247 USA

Phone: (314) 487-7600 Fax: (314) 487-0100

www.beaontechnology.com

E-Mail: sales@beaontechnology.com