

# SPRING ELEVATING TABLES

*AUTOMATICALLY LOWER OR RAISE PLATFORM AS WEIGHT IS ADDED OR REMOVED*



## Series **BETS**

**S**ELF-ELEVATING TABLES, series BETS, is designed to automatically raise or lower as materials are removed or added to the platform, keeping material at an ergonomic work height. These tables increase productivity while reducing potentially harmful bending and twisting motions. The counter balance springs can easily be added or removed to adjust weight to height sensitivity. This feature allows the user to conveniently set the table to fit each application.

### **CASTERS**

- Model BETS-230 & BETS-460 utilize 3-1/2" x 1-3/4" Casters
- Model BETS-840-30, BETS-1120-18 & BETS-1120-24 utilize 4" x 2" Casters



*Ergonomic Handle*

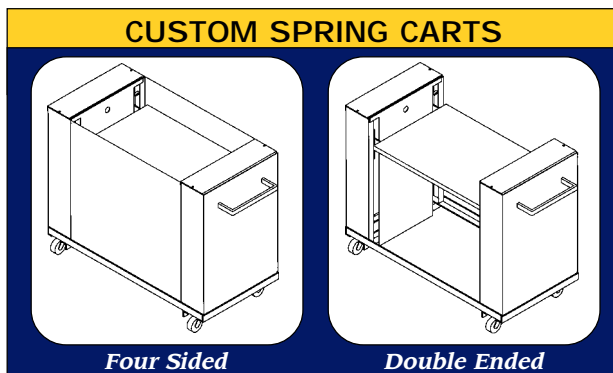

*Four Sided*

*Double Ended*

MODEL NUMBER	PLATFORM SIZE (WIDTH x LENGTH)	CAPACITY (POUNDS)	SERVICE RANGE	OVERALL SIZE (W x L x H)
BETS-230	20" x 20"	230	11" TO 33"	21" x 28" x 37"
BETS-460	20" x 20"	460	11" TO 33"	21" x 28" x 37"
BETS-840-30	30" x 30"	840	15" TO 38"	31" x 38" x 52"
BETS-1120-18	18" x 18"	1,120	15" TO 38"	19" x 26" x 52"
BETS-1120-24	24" x 24"	1,120	15" TO 38"	25" x 32" x 52"



*Take off Backplate to Add or Remove Springs*

