

# PACKAGING EQUIPMENT



**STRETCH WRAP MACHINE**  
Model BSWA-48



**POWERED CAROUSEL**  
Model BPOW-CAR

**STRAPPING MACHINE**  
Model BS-2001



From Stretch Wrapping to Carousels to Strapping Machines your packaging equipment needs are covered. We offer a variety of products that assist in packaging whether by machine or done manually. Increase productivity in your shipping area with Packaging Equipment. Special sizes available.

## SEMI-AUTOMATIC STRETCH WRAP MACHINE

- LOW PROFILE DESIGN
- 90V DC, 1/2 HP VARIABLE SPEED DRIVE
- COUNTERBALANCED FILM DISPENSER
- POWERED MAST AVAILABLE

## POWERED CAROUSEL

- 4,000 POUNDS CAPACITY
- VARIABLE SPEED CONTROL
- 48" DIAMETER TREADPLATE DECK

## SEMI-AUTOMATIC STRAPPING MACHINE

- STAINLESS STEEL DECK
- PORTABLE FOR CONVENIENCE
- EASY ACCESS CONTROL PANEL



**HAND HELD STRETCH WRAP APPLICATOR**  
Model BSW-HAND-R



**EDGE PROTECTORS**  
Model BEDGE

# Semi-Automatic Stretch Wrap Machine

Increase productivity in the shipping department or at the end of a production line with the Semi-Automatic Stretch Wrap Machine. This unit is complete with a 48" diameter powered turntable and counter-balanced stretch film mast (turntable available in diameters up to 60"). Easy to operate, simply depress the foot pedal and manually move the mast up and down. Powered by a 115V, using a 90V DC, 1/2 HP motor with soft start/stop and variable speed control.

The Approach Ramp option allows the operator to load and unload the machine with a pallet jack.

The Powered Mast option is available with a 24V hand control to work with those taller loads. When using, depress on either the up or down button to control the height of the film, while depressing on the foot control. Capacities up to 5,000 lbs. Units come standard with two film rods, 15" and 25" to accommodate 10" and 20" material. Optional rods available.

## Model BSWA-48

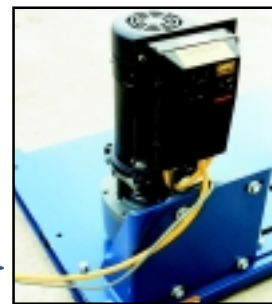

115 V, 1/2 HP Motor

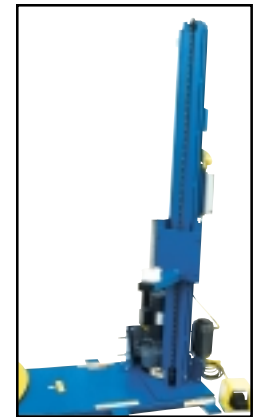

Optional Powered Mast (add suffix -PMO)

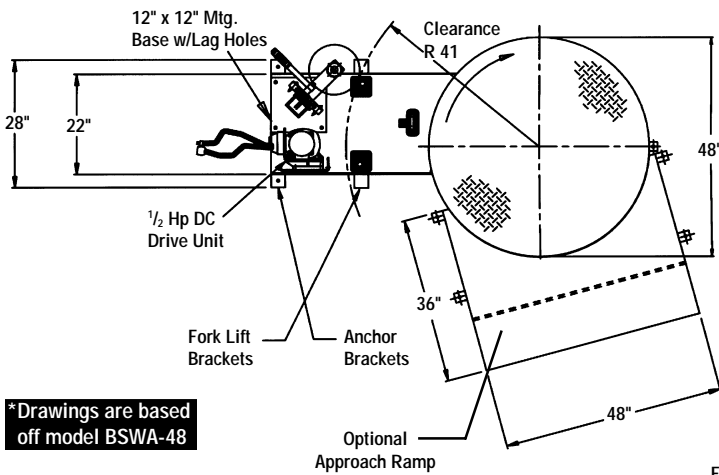

\*Drawings are based off model BSWA-48

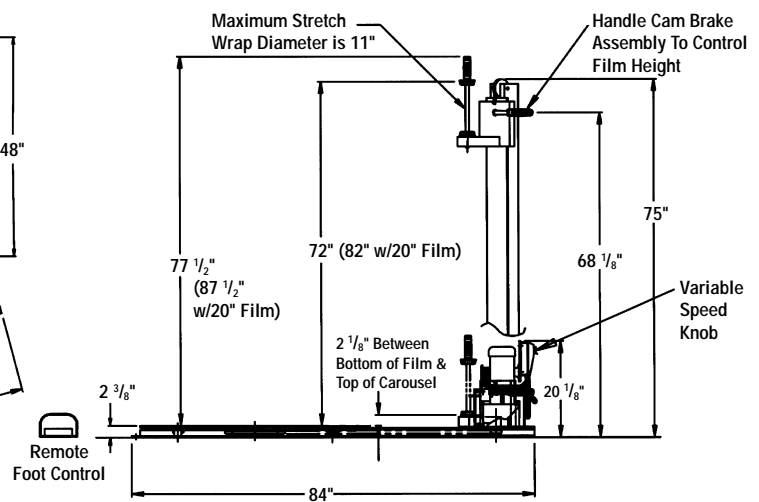

### Stretch Wrap Machine

MODEL NUMBER	CAROUSEL DIAMETER	CAROUSEL HEIGHT	CAPACITY (POUNDS)	# OF PALLETS WRAPPED PER HR.	MAX. LOAD DIAMETER	MAX. LOAD HEIGHT	R.P.M.	MOTOR HP
BSWA-48	48"	2 3/8"	4,000	4 TO 6	76"	78"	3-12	1/2
BSWA-54	54"	11"	5,000	8 TO 12	86"	75"	3-12	1/2
BSWA-60	60"	11"	5,000	8 TO 12	86"	75"	3-12	1/2

### Approach Ramp Option

MODEL NUMBER	WIDTH	LENGTH	HEIGHT
BSWA-R-4836	48"	36"	2 1/8"

\* For use with model BSWA-48

### Powered Mast Option

MODEL NUMBER	MAX. LOAD HEIGHT	MIN. LOAD HEIGHT	MAX. FILM WEIGHT	MOTOR HP
BSWA-PMO	72"	11"	50 lbs.	1/8

PUSH BUTTON HAND CONTROL - 110 V SINGLE PHASE

Extended Heights Available

# Low-Profile Powered Carousel

The Low-Profile Powered Carousel features a heavy duty steel, nonskid treadplate platform 48" in diameter. This unit handles loads up to 4,000 lbs. Standing only 2 3/8" tall, this system is easily accessible with a fork truck; optional approach ramp is available for pallet truck use. Operated with a foot control, the Powered Carousel has a variable speed control, cushion start/stop and rugged 90V DC, 1/2 HP motor with adjustable chain drive. Wall plug is standard 115V/single phase/20 amp.



Model **BPOW-CAR**

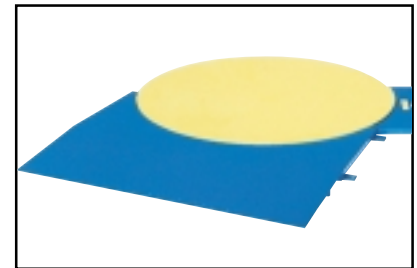

Optional Approach Ramp, model BSWA-R-3648, is available for the BSWA or BPOW series.

MODEL NUMBER	DESCRIPTION	R.P.M.	HEIGHT	CAPACITY (POUNDS)
BPOW-CAR	115V AC POWER WITH FOOT CONTROL	3-12	2 3/8"	4,000
BSWA-R-4836	48"W x 36"L APPROACH RAMP	--	2 1/8"	4,000

*Reverse Option Available*

# Hand Held Stretch Wrappers & Accessories



Maximum Roll Diameter is 8" with a maximum I.D. of 3", minimum of 3/4".  
Maximum Roll Height is 12".

Model **BSWA-HAND-R**

This hand held, lightweight, freewheeling dispenser maintains precision tension control assuring a tight, smooth application. Ergonomic design reduces both bending and fatigue. Now even the bottom row can be wrapped as tightly as the top with help from its foam bent handle. Holds rolls up to 12" high and 8" in diameter. The compact Stretch Wrap Knife is small enough to fit in your pocket. Specially angled cutting head easily slices through stretch wrap material with out sticking or bunching. Safe design will not cut user or products. Made of high-density plastic. Replacement blades available.

MODEL NUMBER	DESCRIPTION
BSW-HAND-R	HAND HELD STRETCH WRAPPER
BSW-KNIFE	STRETCH WRAP FILM KNIFE
BSW-RB	REPLACEMENT BLADES BOX OF (100)
BSRF-10	FILM 10" WIDE x 1,000 FEET (4 ROLLS PER CASE)
BSRF-20	FILM 20" WIDE x 1,000 FEET (4 ROLLS PER CASE)

# Semi-Automatic Strapping Machine

- MINIMIZE PACKAGING TIME • SECURE CONTENTS EFFECTIVELY • USER FRIENDLY CONTROLS
- STAINLESS STEEL STRAPPING SURFACE • PORTABLE FOR CONVENIENCE

## Model **BS-2001**

This fully portable strapping machine dispenses, tightens and seals economical polypropylene strapping around packages or bundles greater than 3". Unit automatically tensions strap and joins the ends with a secure heat weld. The motor automatically switches off when not in use. As the strap is inserted, the motor automatically restarts. Wall plug standard 115V/single-phase 15 amp.

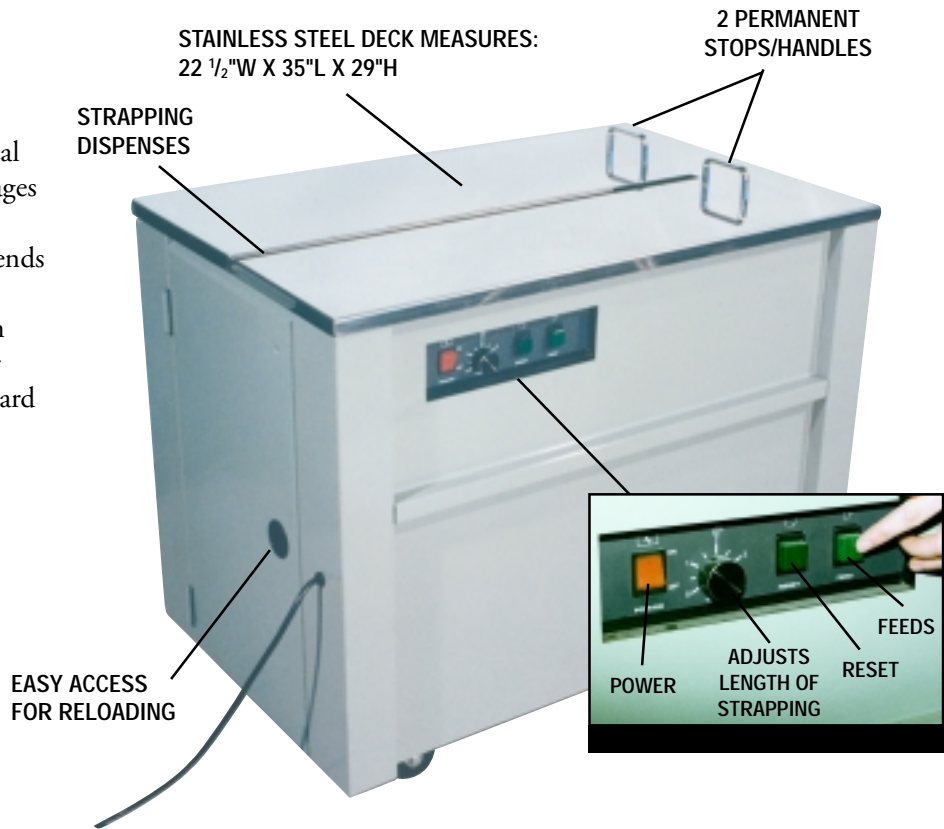

## Edge Protectors

- PLASTIC
- NYLON
- STEEL

Stabilize loads during shipping and prevent damage caused by strap cutting with Edge Protectors. Available in steel, nylon, and plastic. These units work well with steel or plastic strapping.

MODEL NUMBER	CONSTRUCTION	WIDTH (2 SIDED)	HEIGHT
BEDGE-P	PLASTIC	4"	5 1/4"
BEDGE-N	NYLON	4"	5 1/4"
BEDGE-S	STEEL	4 1/2"	6"



### Beacon Industries, Inc.

12300 Old Tesson Rd.  
 St. Louis, MO 63128-2247 USA  
 Phone: (314) 487-7600 Fax: (314) 487-0100  
[www.beacontechology.com](http://www.beacontechology.com)  
 E-Mail: [sales@beacontechology.com](mailto:sales@beacontechology.com)