

SPECIALTY LITE LOAD LIFTS

Low Profile Design



MANUAL HAND CRANK WINCH OPERATION WITH CABLE FOR PRECISE POSITIONING

Transport boxes or small crates with minimal lifting. Ergonomic design allows the operator to load material from ground level. Platform is 1/4" thick with 2" high side lips and completely lowers to ground. Raise and lower material with either a winch or hydraulic foot pump operation. 6" x 2" mold-on-rubber wheels on the back of the lift and 2" diameter semi-steel wheels on the front provide smooth maneuvering from one workstation to another. Horizontal load center is 10" and the capacity is 500 lbs.

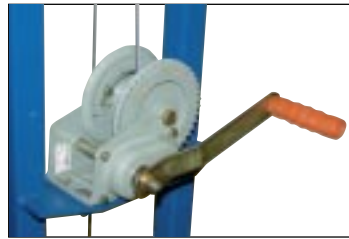

Hand Operated Winch with Automatic Positive Lock or Hydraulic Foot Pump Available

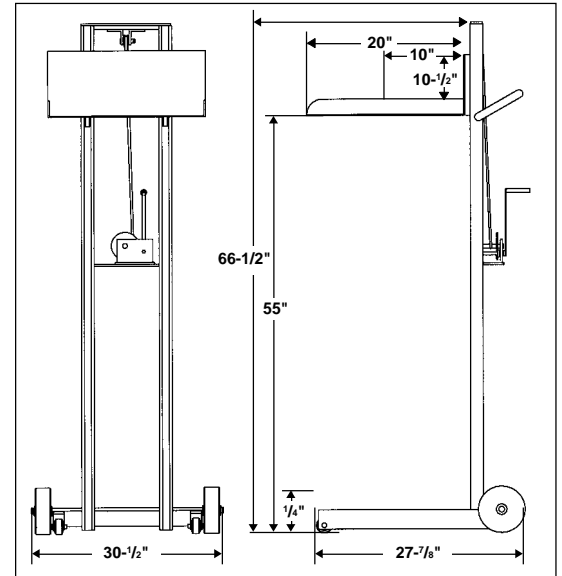

MODEL NUMBER	OPERATION	PLATFORM SIZE (W x L)	SERVICE RANGE	FRONT WHEELS
BLLPW-500-FW	WINCH	20" x 20"	1/4" to 55"	2" RIGID STEEL
BLLPH-500-FW	HYDRAULIC	20" x 20"	1/4" to 50"	2" RIGID STEEL

Low Profile Straddle Design



Load and unload products from ground level with ease. Perfect for packages, small crates and dollies. Transporting and lifting products has never been so easy. Four front 4" swivel casters and two 8" x 2" rear wheels give the operator complete control of the cart. Ideal in warehouses, shipping docks, post offices, grocery stores and inventory rooms. A hand winch with automatic positive lock raises packages up to an ergonomic height.

**Model
BLLPW-500-4SFL**



Load and Unload Product from Ground Level

SPECIFICATIONS

Capacity	500 lbs.
Platform Width	20"
Overall Width	37-1/2"
Platform Length	20"
Load Center	10"
Raised Height	58"
Lowered Height	1/4"
Rear Wheels	8" x 2"
Front Wheels	4" x 2"

