

ERGONOMIC HYDRAULIC

ELEVATING CARTS



Minimize bending and lifting with these Portable Ergonomic Elevating Carts. Materials can be easily loaded onto cart from table, lowered to safe transporting height, and raised to unload at destination. Move easily on four polyurethane casters; two locking swivel and two rigid. All models feature a down speed control valve, manual hydraulic foot pump. All steel construction.



Now available new release lever for lowering the platform to its lowered height. Available on the BCART-400, 800-D, 1000, 1000-LD, and the 1500-D

WORKER FRIENDLY & DEPENDABLE
INCREASE PRODUCTIVITY & PROFITABILITY
SIMPLE OPERATION & DURABLE CONSTRUCTION

BCART-400

BCART-750

BCART-800-D

BCART-800-D-DC

BCART-1000

BCART-1000-DC

BCART-1000-LD

BCART-DS-1000

BCART-1500-D

BCART-1750

BCART-2000

BCART-2000-DC

BCART-650-LT

BCART-400

The Hydraulic Elevating Cart, model BCART-400, is an excellent choice when handling and transporting materials up to 400 lbs. Manual hydraulic foot pump raises the platform up to 29". Lightweight design facilitates easy portability from one work area to another. Casters are 4" polyurethane, two rigid, two swivel with locking brake.

PLATFORM SIZE (W x L)	CAPACITY (POUNDS)	RAISED HEIGHT	LOWERED HEIGHT	CASTER SIZE	OPERATION
17-5/8" x 27-1/2"	400	29"	8-3/4"	4"	MANUAL



BCART-750

The Hydraulic Elevating Cart, model BCART-750, is the perfect cart for handling loads weighing up to 750 lbs. The stable construction allows this unit to be utilized for small dies and conveyor systems. The platform size in conjunction with the raised height, provides ergonomic work positioning. Two rigid and two swivel 5" polyurethane casters are standard.

PLATFORM SIZE (W x L)	CAPACITY (POUNDS)	RAISED HEIGHT	LOWERED HEIGHT	CASTER SIZE	OPERATION
19" x 32"	750	35"	11"	5"	MANUAL



BCART-800-D

The Hydraulic Elevating Cart, model BCART-800-D, is the right choice for products that need that extra boost to a higher shelf or level. The lightweight design makes transporting goods from one workstation to another, virtually effortless with the 5" polyurethane casters, two rigid and two swivel.

PLATFORM SIZE (W x L)	CAPACITY (POUNDS)	RAISED HEIGHT	LOWERED HEIGHT	CASTER SIZE	OPERATION
20" x 35-1/2"	800	51"	13"	5"	MANUAL



BCART-800-D-DC

The Hydraulic Elevating Cart, model BCART-800-D-DC, is the excellent choice for easily handling loads weighing up to 800 lbs. This battery-powered unit can transport loads from one workstation to another with ease. Two button hand control provides quick and easy operation. Unit rolls easily on 5" polyurethane casters, two rigid/two swivel. Optional on board battery charger and battery indicator are available.

PLATFORM SIZE (W x L)	CAPACITY (POUNDS)	RAISED HEIGHT	LOWERED HEIGHT	CASTER SIZE	OPERATION
21-1/2" x 39-1/4"	800	53"	17-3/4"	5"	DC BATTERY



BCART-1000

The Hydraulic Elevating Cart, model BCART-1000, is great for handling loads up to up to 1,000 lbs. Works well in many ergonomic applications. This elevating cart will raise loads from 11" to 35". With its solid built construction, this unit can be utilized for placing heavy dies. Two rigid and two swivel 5" polyurethane casters are standard.

PLATFORM SIZE (W x L)	CAPACITY (POUNDS)	RAISED HEIGHT	LOWERED HEIGHT	CASTER SIZE	OPERATION
19" x 32"	1,000	35"	11"	5"	MANUAL



BCART-1000-DC

The Hydraulic Elevating Cart, model BCART-1000-DC, is a battery powered elevating cart that will lift up to 1,000 lbs. This cart is the right choice for quick lifting and ergonomic material handling. 5" polyurethane casters, two rigid/two swivel, are standard.

PLATFORM SIZE (W x L)	CAPACITY (POUNDS)	RAISED HEIGHT	LOWERED HEIGHT	CASTER SIZE	OPERATION
25-1/2" x 40-1/2"	1,000	35"	15-1/4"	5"	DC BATTERY



BCART-1000-LD

The Hydraulic Elevating Cart, model BCART-1000-LD, is ideal for handling oversized loads. The longer/wider platform size, along with the heavy-duty capacity, enables this unit to handle large loads to provide ergonomic assistance. Model BCART-1000-LD-DC is battery operated.

PLATFORM SIZE (W x L)	CAPACITY (POUNDS)	RAISED HEIGHT	LOWERED HEIGHT	CASTER SIZE	OPERATION
32" x 63"	1,000	36"	11-1/4"	5"	MANUAL
32" x 63"	1,000	38"	14"	5"	DC BATTERY



BCART-DS-1000

The Battery Operated, model BCART-DS-1000, is designed to bring materials to an elevated ergonomic height to reduce bending and reaching. This unit rolls smoothly on 5" poly-on-steel casters. Features include; internal DC power pack, 24 volt hand held pendant control on 8 ft. cord, and a superior design torsion bar for increased side to side stability. Optional battery charger and battery charge indicator available.

PLATFORM SIZE (W x L)	CAPACITY (POUNDS)	RAISED HEIGHT	LOWERED HEIGHT	CASTER SIZE	OPERATION
20" x 33"	1,000	40"	14"	4"	DC BATTERY



BCART-1500-D

The Hydraulic Elevating Cart, model BCART-1500-D, is an excellent choice when handling and transporting materials up to 1,500 lbs. Manual hydraulic foot pump raises the platform up to an ergonomic height. Lightweight design facilitates easy portability from one work area to another. Casters are 5" poly-on-steel, two rigid, two swivel with locking brake.

PLATFORM SIZE (W x L)	CAPACITY (POUNDS)	RAISED HEIGHT	LOWERED HEIGHT	CASTER SIZE	OPERATION
25-1/2" x 49"	1,500	51-1/2"	17-1/4"	5"	MANUAL



BCART-1750

The Hydraulic Elevating Cart, model BCART-1750, is the perfect solution to transport, lift and position problem loads. Platform size in conjunction with the raised height provides ergonomic assistance for personnel. Manual foot pump is used to elevate platform. Casters are 6" poly-on-steel, two rigid, two swivel with locking brake.

PLATFORM SIZE (W x L)	CAPACITY (POUNDS)	RAISED HEIGHT	LOWERED HEIGHT	CASTER SIZE	OPERATION
20" x 39-1/2"	1,750	39"	16"	6"	MANUAL



BCART-2000

Designed for long life as well as providing maximum efficiency when handling loads, this Hydraulic Elevating cart, model BCART-2000, features a 2-speed foot pump, removable deck and hinge pins, internal brass velocity fuses, pressure compensated lowering control valve and dual cylinders. The deck pivots up for easy maintenance. The heavy-duty construction makes positioning of materials seem effortless. Also available in A/C, D/C or Air/Oil.

PLATFORM SIZE (W x L)	CAPACITY (POUNDS)	RAISED HEIGHT	LOWERED HEIGHT	CASTER SIZE	OPERATION
20" x 40"	2,000	39"	15"	4"	MANUAL



BCART-2000-DC

The Hydraulic Elevating Cart, model BCART-2000-DC, is a battery powered cart that will lift up to 2,000 pounds. This heavy-duty cart is perfect for handling larger loads with many different applications. Unit rolls easily on 5" polyurethane casters, 2 rigid, 2 swivel. Optional on board battery charger and battery charge indicator available.

PLATFORM SIZE (W x L)	CAPACITY (POUNDS)	RAISED HEIGHT	LOWERED HEIGHT	CASTER SIZE	OPERATION
20" x 40"	2,000	39"	15"	5"	DC POWERED



BCART-650-LT

Transport heavy containers, molds or pans with this Hydraulic Lift and Tilt Cart. This unit provides continuous motion adjustment for lift and tilt movements. Constructed of steel, the BCART-650-LT, has a platform size of 19" x 32" and can raise loads weighing up to 650 lbs. This cart has a raised height of 27" before tilting 31° giving an overall height of 53-1/2" and a lowered height of 12". The Hydraulic Lift and Tilt Elevating Cart is operated by a hydraulic cylinder with a foot pump for friction free lifts. Rolls smoothly on 2 rigid and 2 swivel 6" x 2" poly-on-steel casters with brakes.

PLATFORM SIZE (W x L)	CAPACITY (POUNDS)	RAISED HEIGHT	LOWERED HEIGHT	CASTER SIZE	OPERATION
19" x 32"	650	27"	12"	6"	MANUAL

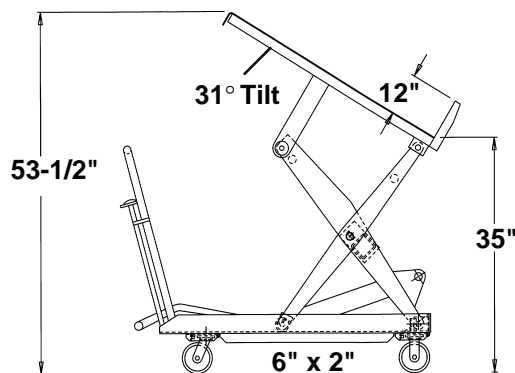

31° TILT



Beacon Industries, Inc.

12300 Old Tesson Rd.

St. Louis, MO 63128-2247 USA

Phone: (314) 487-7600 Fax: (314) 487-0100

www.beacontechnology.com

E-Mail: sales@beacontechnology.com