

B100 Series

Door Seal For a 8' x 8' door and a 8' x 9' door opening.



Beacon Door Seals serve as effective door-seal when doors are open and trucks or trailers are loaded or unloaded. Seals out cold, wind, dust, and fumes. Seals in heated or cooled air. Protects workers and merchandise from environment. Made with solid treated wood and solid foam.

These basic dock seals are designed to fit most standard door sizes. They are designed with beveled vertical pads to provide a tight seal against the truck. Model 160 seals are normally stocked in black.

SPECIFY PAD TYPE & MOUNTING

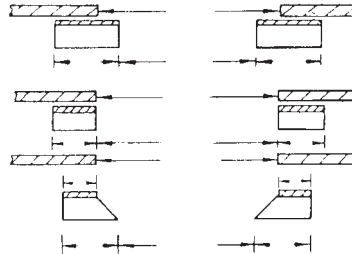

NOTE: OPTION
 4", 8", 16" Pleats
 AVAILABLE

Door-Seal fabric shall be:

- MODEL 130**
 Base: 40 oz. vinyl-coated nylon
 Base Color: Green, Tan, Black, Brown
- MODEL 140**
 Base: 40 oz. Hypalon
 Base Color: Black, Brown, Tan
- MODEL 150**
 Base: 22 oz. vinyl-coated nylon
 Face Reinforcement: 22 oz. vinyl-coated nylon
 Guide Stripe: 22 oz. vinyl-coated nylon-yellow-white
 Base Color (your choice): Green, Black, Tan, Blue, Light Gray, White, Yellow, Red.
- MODEL 160**
 Base: 22 oz. vinyl-coated nylon
 Guide Stripe: 22 oz. vinyl-coated nylon-yellow-white
 Base Color (your choice): Green, Black, Tan, Blue, Light Gray, White, Yellow, Red.
- MODEL 170**
 Base: 16 oz. Hypalon-coated nylon
 Guide Stripe: 22 oz. vinyl-coated nylon-yellow-white
 Base Color: Black Only
- MODEL 180**
 Base: 16 oz. vinyl-coated nylon
 Guide Stripe: 22 oz. vinyl-coated nylon-yellow-white
 Base Color: Black, Green, Brown, Tan
- MODEL 190**
 Base: 40 oz. neoprene-coated nylon
 Guide Stripe: 22 oz. vinyl-coated nylon-yellow-white
 Base Color: Black Only

B101 & B103 Series

Door Seal For a 8' x 10', 9' x 10' & 10' x 10' door opening.

(Adjustable Head Curtain for Doors Higher than 9'0")



The standard Series 101 dock seal features a fixed 24" head curtain for doors higher than 9 ft. A special design, Series 103, features an adjustable head curtain that can be raised or lowered by a "touch-and-hold" pulley arrangement.

WARRANTY. The Beacon Door-Seal is guaranteed against manufacturing defects in material and workmanship for one year from date of installation. Our responsibility under this guarantee shall be entirely fulfilled by furnishing, FOB factory,

SPECIFY PAD TYPE & MOUNTING

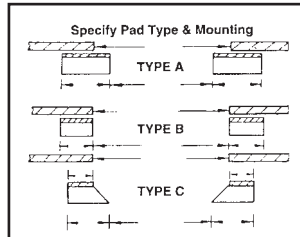

a replacement product or parts; or, at our sole option by refund of the invoice value of the product shown to our satisfaction to be so defective within such guarantee period. This warranty is in lieu of all other express warranties.

Optional Heavy Duty Head Curtain Units can be ordered with Head Curtains manufactured at 40 oz. fabric in Vinyl, Neoprene, or Hypalon.

Door-Seal fabric shall be:

- MODEL 131**
 Head Curtain: 40 oz. Vinyl Coated Nylon.
 Side Pads: 40 oz. Vinyl Coated Nylon.
 Base Color (your choice): Green, Black, Tan, Blue, Brown
- MODEL 141**
 Head Curtain: 40 oz. Hypalon Coated Nylon.
 Side Pads: 40 oz. Vinyl Coated Nylon.
 Base Color (your choice): Black, Brown, Tan, Blue, Brown
- MODEL 151**
 Head Curtain 22 oz. Vinyl Coated Nylon.
 Side Pads: 22 oz. Vinyl Coated Nylon.
 Face Reinforcement: 22 oz. vinyl-coated nylon
 Base Color (your choice): Green, Black, Tan, Blue, Light Gray, White, Yellow, Red, Brown.
- MODEL 161**
 Head Curtain 22 oz. Vinyl Coated Nylon.
 Side Pads: 22 oz. Vinyl Coated Nylon.
 Base Color (your choice): Green, Black, Tan, Blue, Light Gray, White, Yellow, Red, Brown.
- MODEL 171**
 Head Curtain: 16 oz. Neoprene-Coated Nylon.
 Side Pads: 16 oz. Neoprene-Coated Nylon.
 Base Color: Black Only
- MODEL 181**
 Head Curtain: 16 oz. Neoprene-Coated Nylon.
 Side Pads: 16 oz. Neoprene-Coated Nylon.
 Base Color: Green, Black, Brown, Tan, Blue.
- MODEL 191**
 Head Curtain: 40 oz. Neoprene-Coated Nylon.
 Side Pads: 40 oz. Neoprene-Coated Nylon.
 Base Color: Black Only

BD-750 Series

Dock Shelter Ideal for Varying Truck Heights



BD-750 Dock Shelter offers—

- Full height and width access to rear of truck.
- An opportunity to conserve energy.
- Enhanced security.
- Additional personnel safety and morale.
- Decreased product spoilage.

**The following models are available. Select model for at least 10-inch projection beyond bumpers.

- *Model **BD-750-18** with 18-inch projection
- *Model **BD-750-24** with 24-inch projection
- *Model **BD-750-30** with 30-inch projection
- *Model **BD-750-36** with 36-inch projection

Options:

- Steel supporting structure
- 12-foot sides
- Extra depth steel protectors
- Custom built configurations

STANDARD

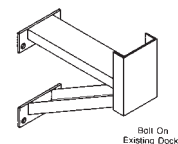

SERIES BSP-ED

TRUCK DOOR SEAL SHOULD BE MODEL B _____

No. of Units _____

Door Size: Width _____ Height _____

Dock Bumper Projection _____

Dock Height _____

Approach Inclined Declined
 Level Degree

Front Opening: Width D _____ Height E _____

Dimensions Outside Unit:
 Width A _____ Height B _____

Projection of Unit C _____

Distance Bottom Horizontal Pad To
 Ground F _____

Horizontal Pad Height G _____

Side Pad Width H _____

Distance Between Door Openings With More Than
 One Door _____

Clearance At Sides and Top of Door For Mounting

Taper Dimension (2" Standard) X _____

Color: _____ Unit With _____ Stripe

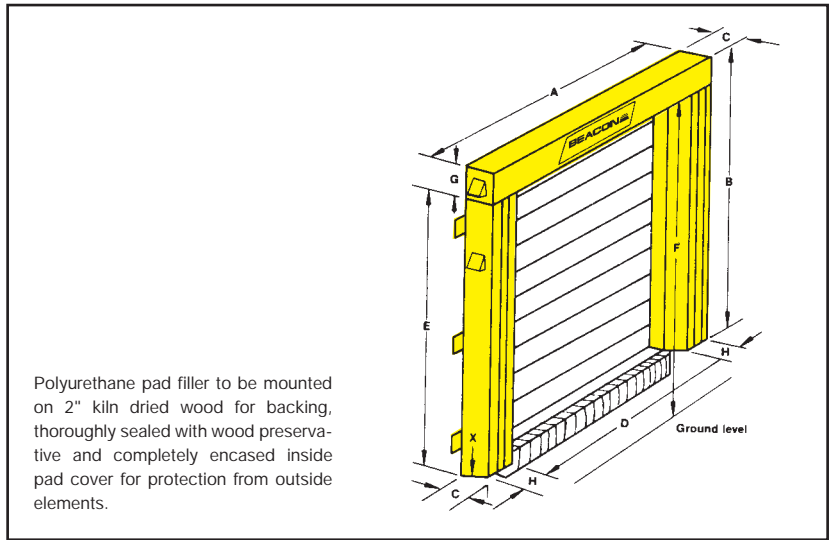

TRUCK DOOR SEAL SHOULD BE MODEL B _____

No. of Units _____

Door Size: Width _____ Height _____

Dock Bumper Projection _____

Dock Height _____

Approach Inclined Declined Level Degree

Front Opening: Width D _____ Height E _____

Dimensions Outside Unit:
 Width A _____ Height B _____

Projection of Unit C _____

Distance Bottom Head Curtain To
 Ground F _____

Head Curtain Height G _____

Side Pad Width H _____

Distance Between Door Openings With More Than
 One Door _____

Clearance At Sides and Top of Door For Mounting

Color: _____ Unit With _____ Stripe

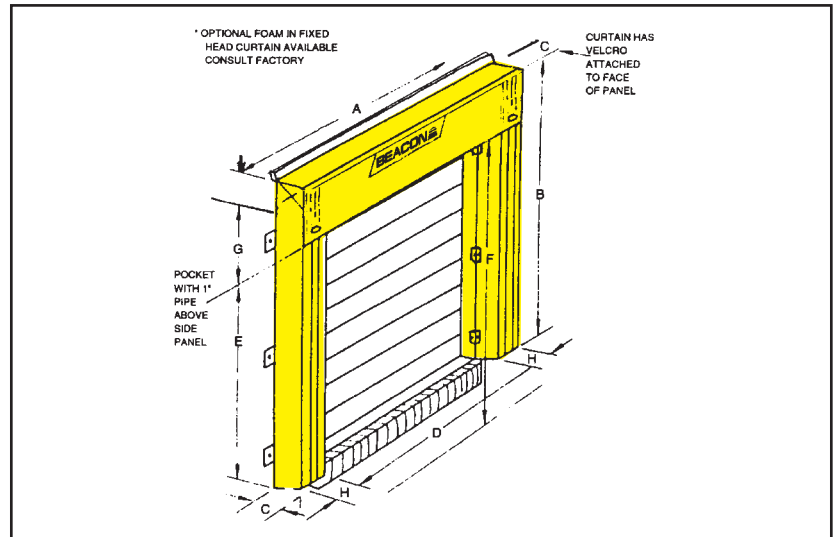

Truck DOCK SHELTER shall be Model BD-750-XX**

The shelter shall be built to fit a door opening _____ wide by _____ high. The two side pieces shall be 126 inches high and close opening to 90 inches between flaps. The top shall be 132 inches wide and 6 inches high plus a 36-inch flap coming down into doorway. The complete covering shall be 40-ounce black vinyl-coated nylon plus 40-ounce pleats. The supporting structure shall be 2 x 4 wolmanized lumber. A protective edging of extruded aluminum shall go around the entire perimeter of the dock shelter. Bottom corner fillers and steel protectors to be included.

