

**Ergonomic Solutions**

# OWNER'S MANUAL

## TILTING WORK TABLE MODEL BWT-2424 & BWT-2221

<b>Contents</b>	
Warnings and Safety Instructions .....	1
Receiving Instructions .....	1
Operating Instructions .....	1
Caster Installation .....	2
Parts Identification & Drawing (BWT-2424) ....	3
Parts Identification & Drawing (BWT-2221) ....	4

### WARNINGS & SAFETY INSTRUCTIONS

**Read owner's manual completely before operating unit!**

- Keep hands and feet away from all moving parts while table is in use.
- Do not attempt to adjust the height or tilt of the table with a load on the platform.
- Never stand on table.
- Remove weight before performing any repairs on the table.
- Use only maintenance parts supplied or approved by the manufacturer.
- Always utilize all wheel brakes when table is not being moved.
- Never exceed the maximum loading capacity of 300 lbs.
- Load must be evenly distributed on table to ensure maximum stability.
- Always make sure the height adjustment screw is securely tightened after table has been raised or lowered.
- Failure to follow these guidelines may result in personal injury.

- 3) Loosen height adjustment screw and adjust work table to desired height using the handwheel located on the baseframe.
- 4) Tighten height adjustment screw.
- 5) Adjust the tilt angle of the table to the desired position using the handwheel directly under the table platform.
- 6) Place load on table.

### OPERATING INSTRUCTIONS (WT-2221)

- 1) Position the work table near desired work area.
- 2) Lock casters.
- 3) Adjust height to correct level by depressing snap button located on the center column and sliding up or down.
- 4) Loosen tilt adjustment knob under platform. Tilt deck to desired angle and retighten.
- 5) Place load on table.

### RECEIVING INSTRUCTIONS

Every unit is thoroughly tested and inspected prior to shipment. However, it is possible that the unit may incur damage during transit. If you see damage when unloading make a note of it on the SHIPPER RECEIVER.

Remove all packing and strapping material, inspect for damage. IF DAMAGE IS EVIDENT, FILE A CLAIM WITH THE CARRIER IMMEDIATELY!

### OPERATING INSTRUCTIONS (WT-2424)

- 1) Position the work table near desired work area.
- 2) Lock casters.

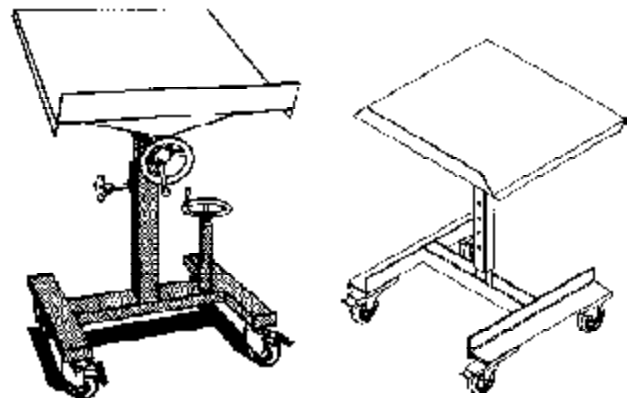

**TILTING WORK TABLE  
MODEL BWT-2424 & BWT-2221**

---

## CASTER MOUNTING INSTRUCTIONS

Securely prop up one end of the carts frame high enough for the casters to fit underneath that end. You will see four caster mounting brackets welded to the bottom of the carts frame, one at each corner.

If you have both swivel and rigid caster, the casters are to be mounted in adjacent pairs. Typically, the swivel casters are mounted to the side on which the push handle is located (when applicable). Determine the proper locations for the casters before you begin.

Turn th included machine screws a couple of threads into the two threaded holes in the ends of each of the caster mounting brackets.

To install the casters onto the cart:

Instert either of the short sides of the caster's top plate into the curled end of the caster mounting bracket.

Raise the other end of the caster's top plate up into the mounting bracket, and secure it there by screwing in the machine screws completely. The scres should extend underneath the caster's top plate, thereby retaining it in the bracket.

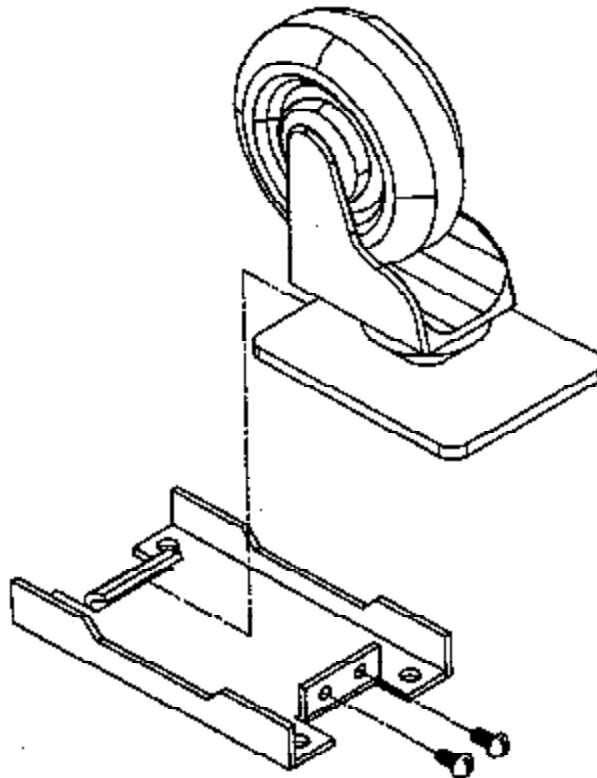

## PARTS IDENTIFICATION FOR BWT-2424

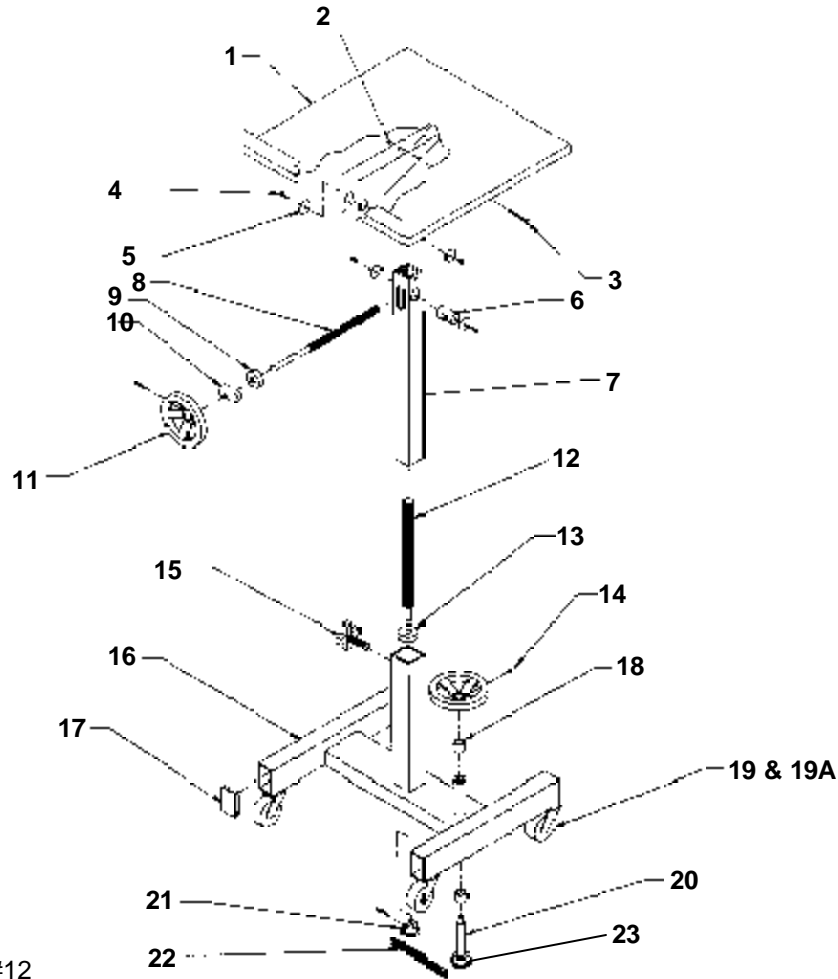

Lightly oil screws #8 and #12 semiannually or as required.

ITEM NO.	DESCRIPTION	ENGINEER NO.	PART NO.	QUANTITY
1	Tabletop Weldment	B16-513-003	BWT-TAB	1
2	3/8-16" Nylok Nut	B37024	A/L	1
3	3/8-16 X 3" UNC H.H.C.S.	B11115	A/L	1
4	1/4-20 X 1/2" UNC H.H.C.S.	B11003	A/L	4
5	1/4" I.D. X 1-1/4" O.D. Fender Washer	B33208	A/L	4
6	Tilt Boss Sub Assembly	B16-526-002	BWT-TBA	1
7	Inner Upright	B16-514-017	BWT-IU	1
8	Tilt Thread	B16-526-001	BWT-TT	1
9	1/2" I.D. Thrust Bearing	B16-110-001	BWT-.5TB	1
10	Pivot Boss	B16-020-002	BWT-PB	1
11	Handwheel / Crank	B16-145-006	BWT-HC	2
12	Elevating Thread	B16-026-002	BWT-ET	1
13	3/4" I.D. Thrust Bearing	B16-110-002	BWT-.75TB	1
14	3/16" x 1-1/2" Spring Pin	B64137	A/L	3
15	Locking Screw, Height Adjustment	BKNOB 2-5	BWT-LS	1
16	Base Assembly	B16-514-024	BWT-BA	1
17	Plastic End Cap, Base Tube	BREC -1-1½ x 3-11GA	BWT-PC	4
18	7/8" I.D. x 1-1/8" O.D. Brass Bushing	B01-111-037	BWT-BB	2
19	3" Swivel Caster w/brake	B06-132-002	BWT-SC/B	2
19A	3" Swivel Caster	B16-132-003	BWT-SC	2
20	Crank Rod	16-645-005	BWT-CR	1
21	Elevating Thread Sprocket	16-042-002	BWT-ETS	1
22	#40 Standard Roller Chain	16-042-001	BWT-RC	1
23	Sprocket Weldment	16-042-002	BWT-SP	1

A/L Available at local hardware store

**EXPLODED PARTS LIST  
MODEL BWT-2221**

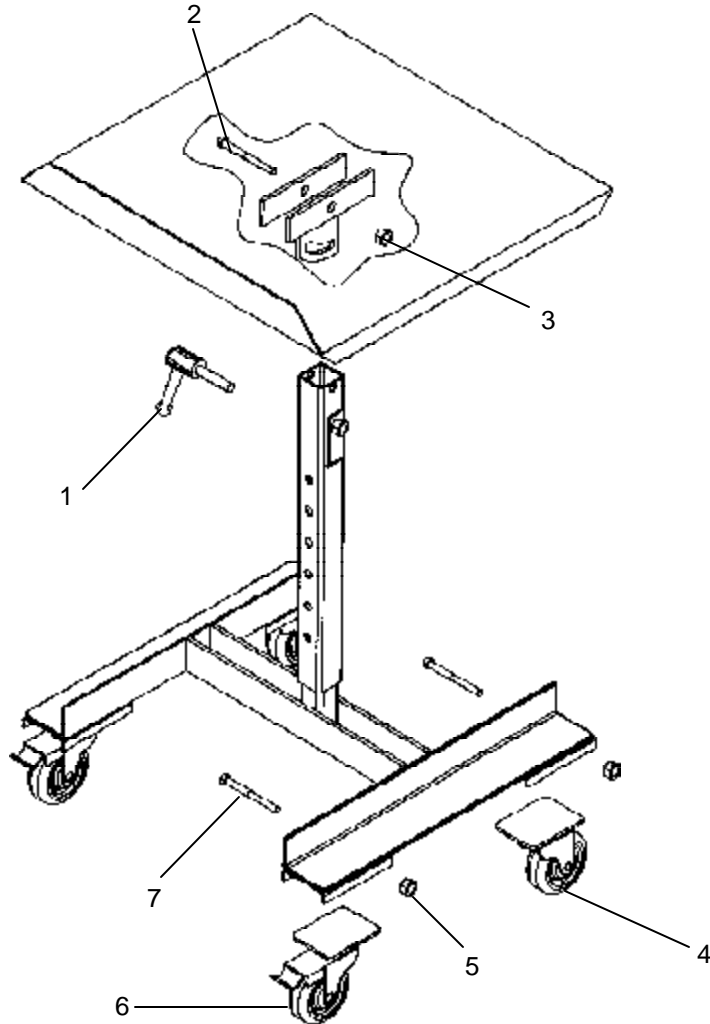

ITEM NO.	DESCRIPTION	ENGINEER NO.	PART NO.	QTY.
1	Handle Tilt Adjusting	B16-025-008	BWTP-HTA	1
2	Bolt 1/2-13 x 2-3/4	B11214	BWTP-BLT	1
3	1/2-13 Nylock Nut	B37030	BWTP-NN-1	1
4	Swivel Caster	B16-132-072	BWTP-SCSTR	2
5	1/4-20 Nylock Nut	B37018	BWTP-NN-2	4
6	Swivel Caster/Total Lock	B16-132-002	BWPT-SCSTR-TB	2
7	Bolt 1/4-20 x 3-1/2 - Carriage	B21117	BWTP-CRGE	4