

12300 Old Tesson Rd. • St. Louis, MO 63128-2247 USA
Phone: (314) 487-7600 Fax: (314) 487-0100
www.beacontechnology.com
E-Mail: sales@beacontechnology.com

Ergonomic Solutions

OWNER'S MANUAL

SELF ELEVATING TABLE MODEL BETS-460

Contents

Warnings And Safety Instructions	1	Parts List	3
Receiving Instructions	1	Warning Label Identification	4
Operating Instructions	1	Limited Warranty/Service Record	5
Loading Chart	2		

WARNINGS & SAFETY INSTRUCTIONS

Read owner's manual completely before operating unit!

- Never load the unit unless you are watching it.
- Do not operate unless all guards are in place and secure.
- Keep hands and feet clear of all moving parts.
- Never exceed the maximum loading capacity of 460 lbs.
- Load must be evenly distributed on table to insure stability.
- Consult factory for uneven loading.
- Always operate unit on a level surface to insure stability.
- Always apply wheel brakes when unit is not been moved.
- Use caution in moving a loaded cart; avoid obstructions and floor defects.
- Always be sure that all of the springs in use are securely attached to their hanger bars.
- Always leave at least four (4) springs in use at all times.
- Remove weight before working on unit.
- Never go under platform if there is weight on unit.
- Use only maintenance parts supplied or approved by the manufacturer.
- Consult factory if adding or performing any modification to the original equipment.
- Make sure all operator safety labels are in place (p.4).
- Failure to follow these guidelines may result in personal injury or death.

MODEL NUMBER AND CAPACITY

The model number, serial number and capacity is inscribed on the nameplate. Please remember to include these numbers in any correspondence with your dealer or the factory.

OPERATING INSTRUCTIONS

- 1) Position the work table near desired work area.
- 2) Lock back casters.
- 3) Determine initial total weight of the items that are to be placed on table.
- 4) Refer to the provided load chart for the proper number of springs to use.
- 5) Remove the front cover and unhook the number of springs that are not going to be used from the bottom spring hanger bars. Properly unhooked springs can be left hanging from the top spring hanger bars.
- 6) Replace the front cover.
- 7) Place the previously specified load on table.
- 8) At the end of each run of parts, remove the front cover and rehook all 14 springs to the bottom spring hanger bars.
- 9) Replace the front cover.

RECEIVING INSTRUCTIONS

Every unit is thoroughly tested and inspected prior to shipment. However, it is possible that the unit may incur damage during transit. If damage is noticed when unloading, make a note of it on the **BILL OF LADING**. Remove all packing and strapping material, then inspect the unit again for damage. **IF DAMAGE IS EVIDENT, FILE A CLAIM WITH THE CARRIER IMMEDIATELY!**

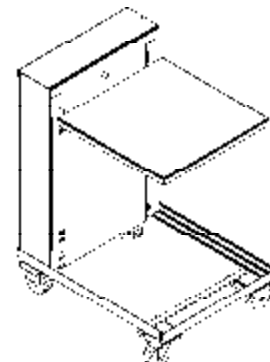

**SELF ELEVATING TABLE
MODEL BETS-460**

NUMBER OF SPRINGS

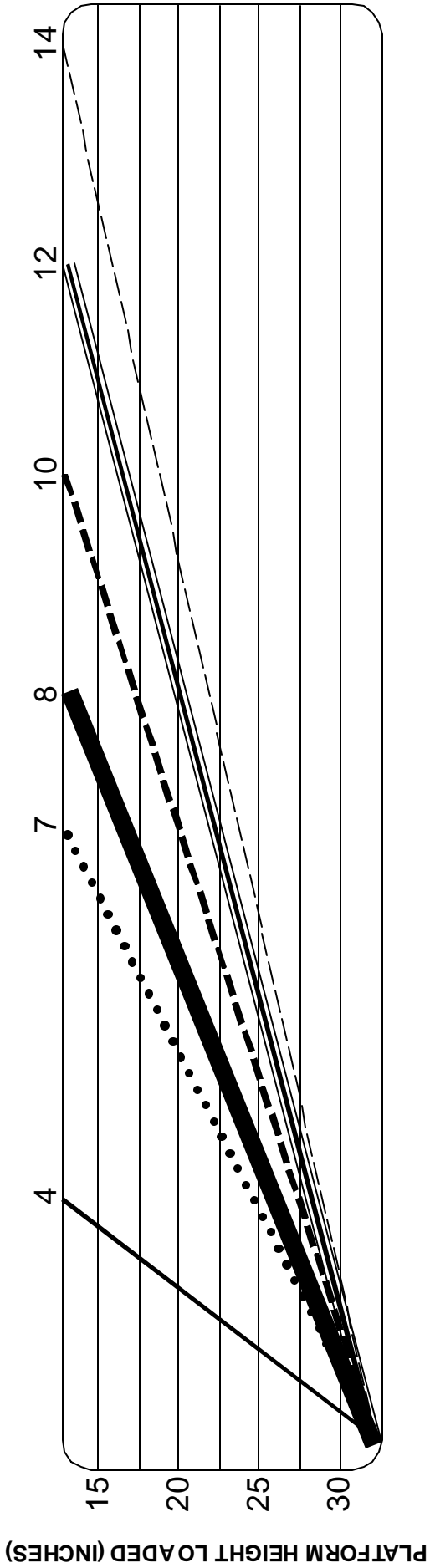

WEIGHT (POUNDS) ON PLATFORM

MODEL ETS-460 LOAD CHART & SPRING GUIDE

This chart is helpful in determining the number of springs necessary to counterbalance your load requirement.

- 1.) Determine the **Maximum Weight** of your application.
- 2.) Using the line graph, locate the closest line intersecting the weight.
- 3.) Reference this line to the **Number of Springs** required to counterbalance loaded table.

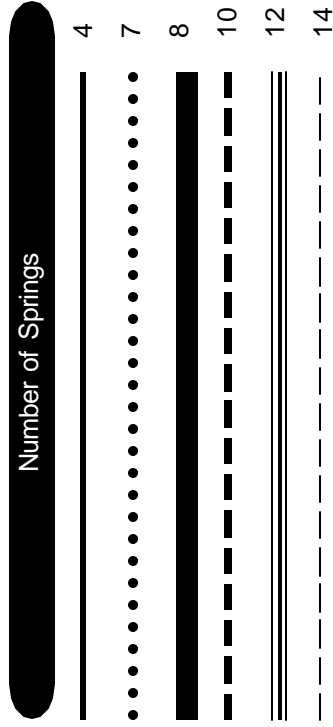

SPRING ELEVATING TABLE • BETS-460 SERIES

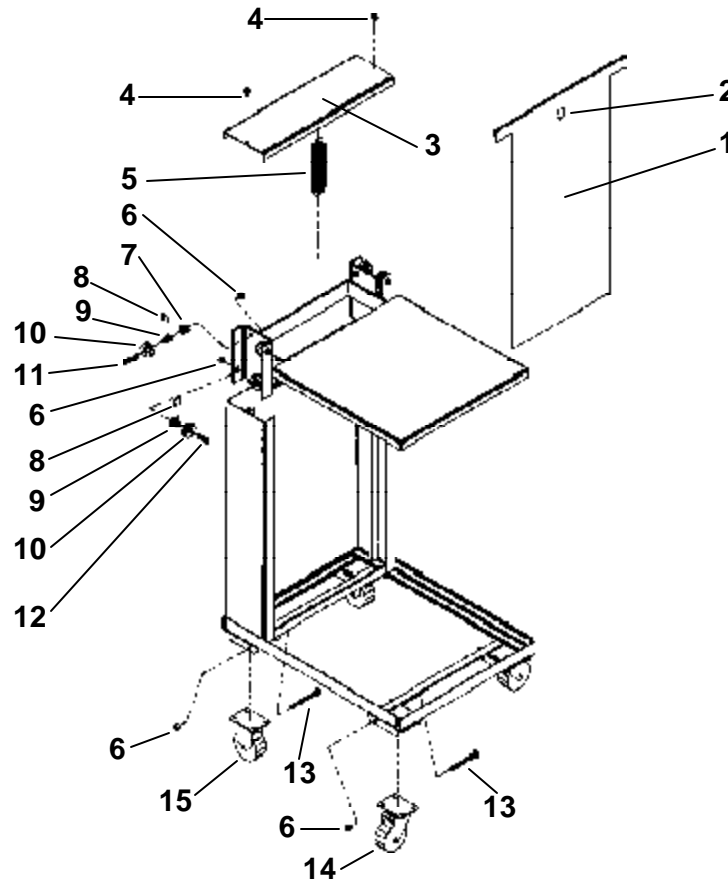

PARTS IDENTIFICATION SELF ELEVATING TABLE • ETS-460 SERIES

KIT NO.	ITEM NO.	DESCRIPTION	ENGINEER NO.	PART NO.	QTY.
	1	Front cover panel	B21-014-002	BETS-FCP	1
	2	Lifting hole grommet	B01-034-021	BETS-LHG	1
	3	Top plate / top spring bar assembly	B21-514-020	BETS-TPABA	1
A	4	Screw, 1/4"-20 x 3/4"(thread cutting HWH-type F)	B32408	BETS-SCRW	2
	5	Extension spring	B21-146-003	BETS-EXTSP	14
A,B	6	Nylock nut, 3/8"-16	a/k	a/k	8
B	7	Spacer bushing, 3/8" ID x 7/8" OD x 0.688"	B21-113-020	BETS-NYLN	4
B	8	"E" clip, 5/8" shaft dia.	B5133-62	BETS-ECLP	8
B	9	Bolt-on bearing post	B21-113-021	BETS-BOBP	8
B	10	Roller bearing (MFG. EQUIP & SUPPLY)	B6203-2RS	BETS-RLRB	8
A,B	11	Bolt, 3/8"-16 x 2 1/4" (BHSCS)	a/k	a/k	4
A,B	12	Bolt, 3/8"-16 x 1 3/4" (BHSCS)	a/k	a/k	4
A,C	13	Bolt, 3/8"-16 x 5"	a/k	a/k	4
C	14	Wheel, caster (rigid)	B16-132-003	BETS-CSTRR	2
C	15	Wheel, caster (swivel w/ brake)	B16-132-002	BETS-STRSWB	2
	A	Bolt Kit (includes 4,6,11-13)	B21-154-001	BETS-KITA	1
	B	Bearing Kit (includes 6-12)	B21-154-002	BETS-KITB	1
	C	Caster Kit (includes 13-15)	B21-154-003	BETS-KITC	1

A/L Available at local hardware store

WARNING LABEL IDENTIFICATION

MAKE SURE ALL WARNING LABELS ARE IN PLACE!

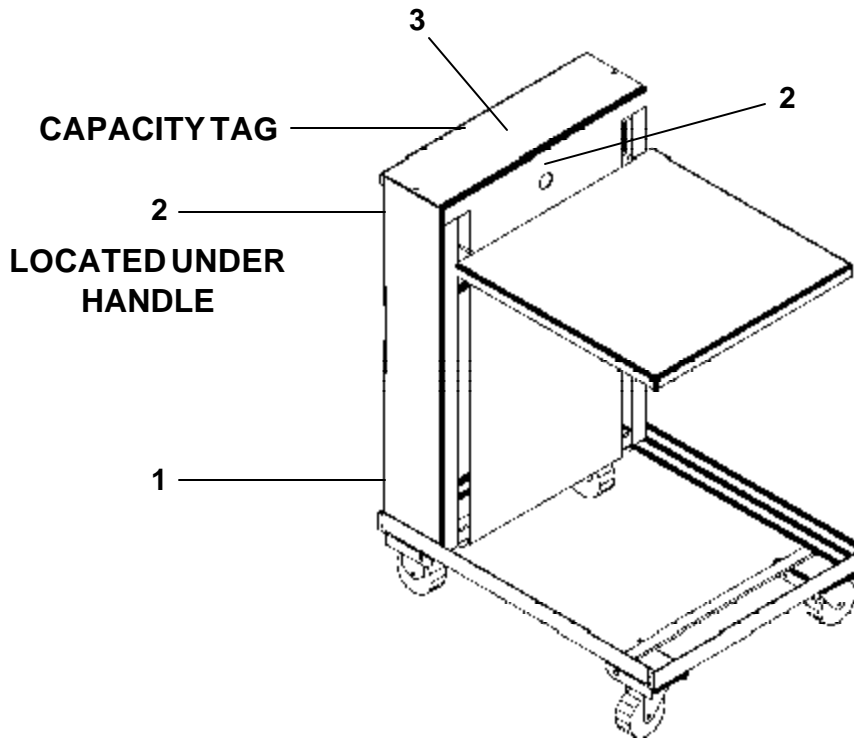

CAPACITY TAG
2
LOCATED UNDER
HANDLE

1

FOR USER INSTRUCTIONS OR QUESTIONS CONTACT 205
 PARA INSTRUCCIONES DE USO Ó CONSULTAS CONTACTAR
 POUR INSTRUCTIONS OU QUESTIONS SUPPLÉMENTAIRES CONTACTER

2

⚠ WARNING	⚠ AVISO	⚠ AVERTISSEMENT
KEEP CLEAR WHEN IN USE	MANTENGASE ALEJADO CUANDO SE ESTA OPERANDO	SE TENIR À DISTANCE LORS DU FONCTIONNEMENT
		220

*Product safety signs or labels should be periodically inspected and cleaned by the product users as necessary to maintain good legibility for safe viewing distance. ANSI 535.4 (10.21)
 Contact manufacturer for replacement labels.

3

⚠ CAUTION
DO NOT OBSTRUCT PLATFORM
⚠ PRECAUCION
NO OBSTRUYA LA PLATAFORMA
⚠ PRUDENCE
NE PAS ENCOMBRER LA PLATE-FORME
304

LIMITED WARRANTY

ONE YEAR LIMITED WARRANTY. The manufacturer warrants for the original purchaser against defects in materials and workmanship under normal use one year after date of purchase. (Not to exceed 15 months after date of manufacture.) Any part which is determined by the manufacturer to be defective in material or workmanship and returned to the factory, shipping costs prepaid, will be, as the exclusive remedy, repaired or replaced at our option. Labor costs for warranty repairs and/or modifications are not covered unless done at manufacturer's facilities. Any modifications performed without written approval of the manufacturer may void warranty. This limited warranty gives purchaser specific legal rights which vary from state to state.

LIMITATION OF LIABILITY. To the extent allowable under applicable law, the manufacturer's liability for consequential and incidental damages is expressly disclaimed. The manufacturer's liability in any event is limited to, and shall not exceed, the purchase price paid. Misuse or modification may void warranty.

WARRANTY DISCLAIMER. Our company has made a diligent effort to illustrate and describe the products shown accurately; however, such illustrations and descriptions are for the sole purpose of identification, and do not express or imply a warranty that the products are merchantable, or fit for a particular purpose, or that the products will necessarily conform to the illustrations or descriptions.

The provisions of the warranty shall be construed and enforced in accordance with the UNIFORM COMMERCIAL CODE and laws as enacted in the State of Indiana.

DISPOSITION. Our company will make a good faith effort for prompt correction or other adjustment with respect to any product which proves to be defective within the Limited Warranty. Warranty claims must be made in writing within said year.

SERVICE RECORD

DATE OF SERVICE: ____/____/____
WORK DONE BY: _____
SERVICE PERFORMED: _____

DATE OF SERVICE: ____/____/____
WORK DONE BY: _____
SERVICE PERFORMED: _____

DATE OF SERVICE: ____/____/____
WORK DONE BY: _____
SERVICE PERFORMED: _____

DATE OF SERVICE: ____/____/____
WORK DONE BY: _____
SERVICE PERFORMED: _____

DATE OF SERVICE: ____/____/____
WORK DONE BY: _____
SERVICE PERFORMED: _____

DATE OF SERVICE: ____/____/____
WORK DONE BY: _____
SERVICE PERFORMED: _____

