

Ergonomic Solutions

OWNERS MANUAL

ELECTRIC HYDRAULIC SCISSOR TABLE MODEL BEHLT

Contents

Warning and Safety Instructions	1-2	Hydraulic Operation & Schematic	8-9
Receiving Instructions	1	Exploded Parts Drawing	10
Loading Instructions	3	Parts List	11
Operating Instructions	3	Trouble Shooting Guide	12-13
Installation Instructions	4	Limited Warranty	13
Electric Schematic	5	Power Unit Specifications	14
Primary Wiring	6	Periodic Maintenance Instructions	15
Power Conversion	7	Warning Label Identification	16

WARNINGS & SAFETY INSTRUCTIONS

Read owner's manual completely before operating unit!

- Not a personnel lift. Keep clear when operating
- Never go under platform if there is weight on unit.
- Remove weight before working on unit.
- Use only maintenance parts supplied or approved by the manufacturer.
- Do not change pressure relief valve setting.
- Do not clamp cylinder in vise as you may distort barrel.
- Never operate lift unless you are watching it.
- Load lift as uniformly as possible.
- Consult factory for uneven loading.
- Do not continue to hold down the UP control if unit is not raising.
- Relieve system pressure by holding DOWN button after unit has come to rest.
- Consult factory if adding conveyor top or performing any modification to the original equipment.
- Do not use hydraulic oils, brake fluids or jack oils. Use AW-32 Hydraulic Oil.
- Make sure all operator safety labels are in place.

THE CARRIER IMMEDIATELY! Also, check the unit size, type of power unit, etc., to ensure the unit is correct for the intended application.

MODEL NUMBER AND CAPACITY

The model number, serial number and capacities are inscribed on the nameplate. Please remember to include these numbers in any correspondence with you dealer or the factory.

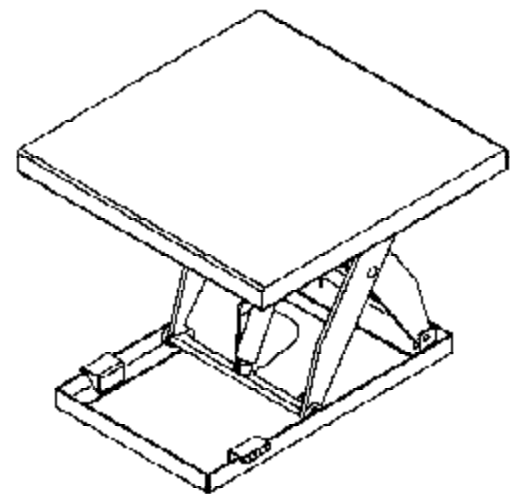

RECEIVING INSTRUCTIONS

Every unit is thoroughly tested and inspected prior to shipment. However, it is possible that the unit may incur damage during transit. If you see damage when unloading make a note of it on the BILL OF LADING.

Remove all packing and strapping material, inspect for damage. IF DAMAGE IS EVIDENT, FILE A CLAIM WITH

ELECTRIC HYDRAULIC SCISSOR TABLE SERIES BEHLT

WARNINGS AND SAFETY INSTRUCTIONS

for Electric Hydraulic Scissor Table

*** Make copies of this page and post in a highly visible location where the lift is being operated and on the company bulletin board.

- Never go under platform if there is weight on the lift.
- Be sure all safety labels are in place (see Owner's Manual)
- Do not go near leaks - high pressure oil easily punctures skin causing injury, gangrene, and death.
- Remove weight, disconnect power, install maintenance stops before working on unit.
- Do not operate lift unless it is securely anchored to the floor.
- Read Owner's Manual completely before operating or servicing this equipment.
- Never use a damaged lift or one that is making unusual noises.
- Do not change pressure relief valve setting on pump.
- Do not clamp hydraulic cylinder in a vise as you may distort the barrel.
- Never operate the lift unless you are watching it.
- Load the lift as uniformly as possible. Consult the factory for uneven loading capacities.
- Do not continue to operate the UP control if unit is not raising.
- Relieve system pressure by operating the DOWN control after unit has come to rest.
- Do not perform any modification to the original equipment without written manufacturer's approval.
- Do not use brake fluids or jack oils. Use AW-32 or H015 Hydraulic fluid, Dexron II or III transmission fluid, or equivalent.
- Maintenance and repairs are to be done only by personnel qualified to perform the required work.
- Use only maintenance parts supplied or approved by the manufacturer.

LOADING INSTRUCTIONS

The load capacity rating as inscribed on the nameplate of your unit designates the net capacity, assuming the load is centered. This capacity must never be exceeded, as permanent damage or injury may result.

OPERATING INSTRUCTIONS

This unit is furnished with a constant pressure ("deadman" type) push button control. Depressing the "UP" (or RAISE) button operates the power unit to raise the platform. The platform will rise as long as the "UP" button is pressed.

On releasing the control, the unit will cease to rise and will remain at that particular elevation.

On depressing the "DOWN" (or LOWER) button, the lowering valve is energized. The cylinders retract as the oil returns to the reservoir and, upon releasing the control, the unit will cease to lower, remaining at that particular elevation. Be certain no person or object is in the way when the unit is descending.

In the event the unit is overloaded, it will not raise because the relief valve will open due to excessive pressure build up in the hydraulic system.

Always remember that the motor runs only when the "UP" button is depressed and the Down Solenoid Valve is energized only when the "DOWN" button is depressed.

SAFETY INSTRUCTIONS TO THE OPERATOR

- 1.) Always load the unit properly.
- 2.) Never use the lift if it is in need of repairs or in the case of malfunction.
- 3.) Notify your maintenance personnel in case you notice anything out of the ordinary, such as binding, odd pump noises, etc.
- 4.) Do not continue to depress the "UP" control if the unit is not raising. You can permanently damage the motor or pump by doing so.
- 5.) Stand to the side when operating. Stay clear of moving parts.

ORDERING REPLACEMENT OR EXTRA PARTS

Our company takes pride in using the finest available parts for our equipment. We are not responsible for equipment failure resulting from the use of unapproved replacement parts. To order replacement or extra parts for your equipment contact Customer Service at the factory. In any correspondence with the factory please include the **Serial Number** which is inscribed on the nameplate of the piece of equipment. Use only the part numbers provided in this Owner's Manual. When ordering parts for AC power units please indicate the motor phase and voltage that the equipment is operating on.

INSTALLATION INSTRUCTIONS

Review Complete Owner's Manual Before Commencing Installation.

For installation you will need the following:

- 1.) A fork truck or hoisting means.
- 2.) Lag bolts, masonry drill, masonry bit, wrench for lag bolt, grout, and steel shims.
- 3.) A power circuit with the specified voltage, including fuses and circuit breakers. (See Electrical Section.)
- 4.) Minimize voltage drop by using adequate wire size.

Move the lift with straps or forks under the frame.

Read all the warning labels on the lift and be sure all of the labels are on the lift.

Check local codes pertaining to your application.

Be sure maintenance prop is in place before getting under platform.

After anchoring to the floor, shim or grout under the full length of the frame sides. The entire length of the frame sides must be supported.

Connect power source as indicated in electrical section. Use only qualified personnel.

Operate the lift through a few cycles. Check and add oil if necessary. See oil specification elsewhere in this manual.

Clean up any debris or spilled oil.

ELECTRIC SCHEMATIC

OVERCURRENT PROTECTION AND DISCONNECTING MEANS ARE TO BE PROVIDED BY OTHERS.

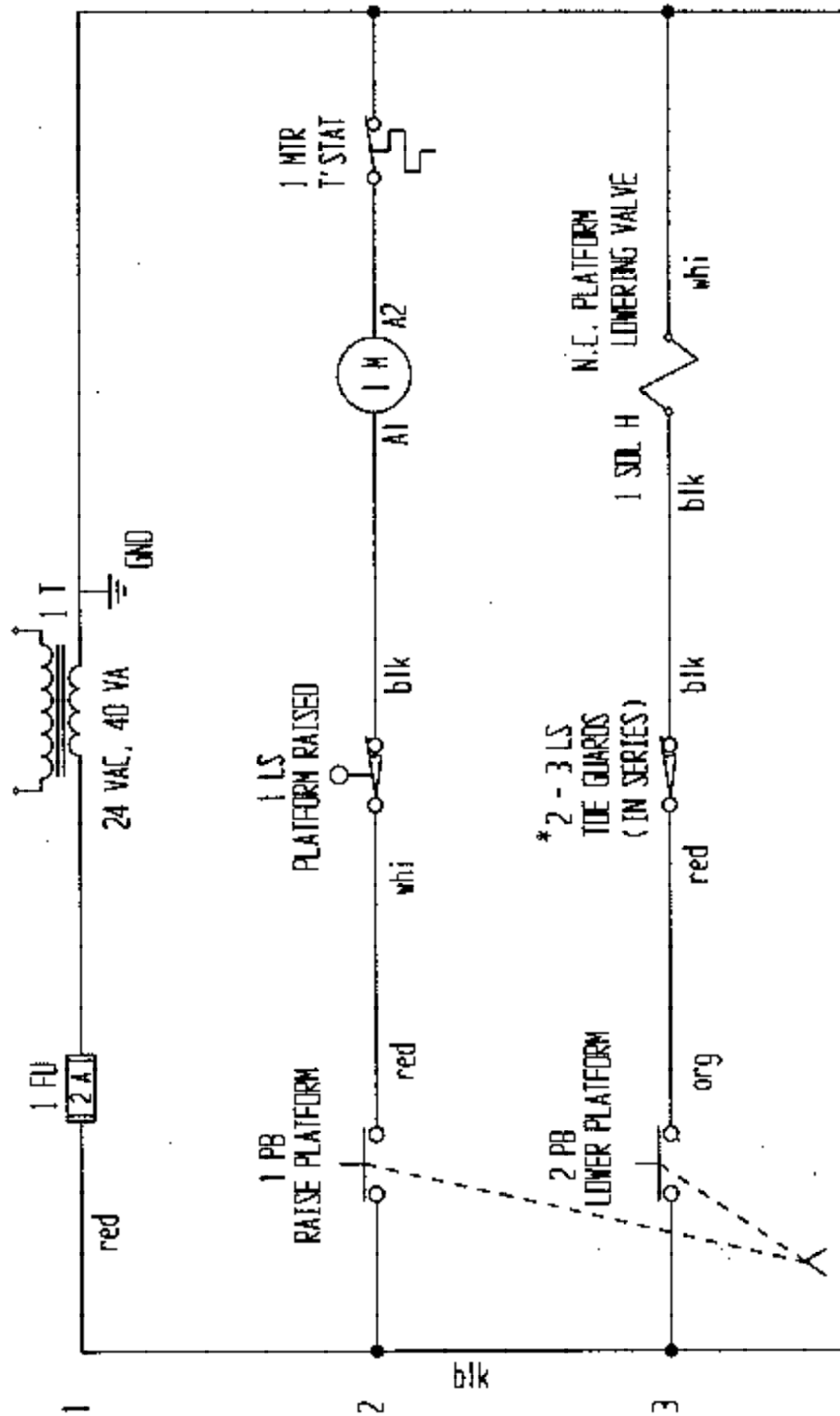

NUMBER OF TOE GUARD SWITCHES CAN VARY ACCORDING TO PLATFORM SIZE.

BE SURE ALL POWER IS OFF BEFORE ATTEMPTING TO WORK ON THIS EQUIPMENT!

CAUTION: SERVICE WORK SHOULD BE PERFORMED ONLY BY TRAINED AND QUALIFIED PERSONNEL.

PRIMARY WIRING FOR CONTROL TRANSFORMER

208V, 3-PHASE
FUSING AND
DISCONNECT
TO BE PROVIDED
BY OTHERS

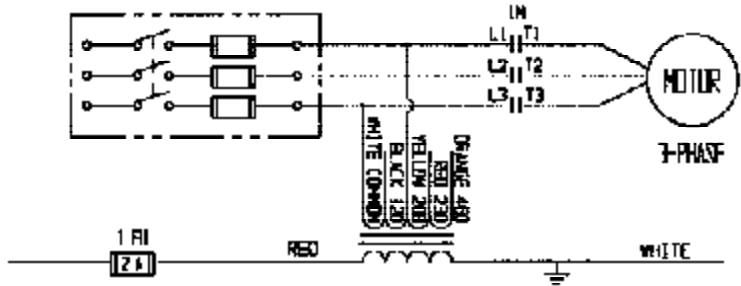

230V, 3-PHASE
FUSING AND
DISCONNECT
TO BE PROVIDED
BY OTHERS

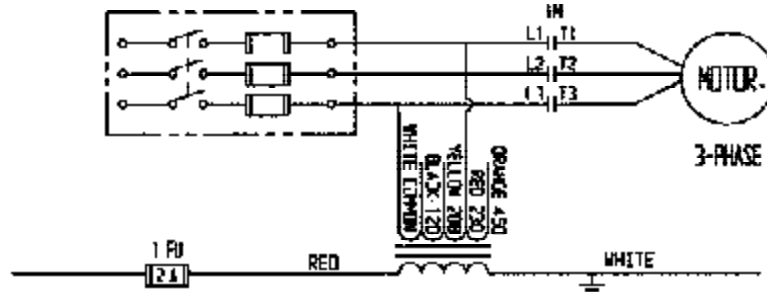

460V, 3-PHASE
FUSING AND
DISCONNECT
TO BE PROVIDED
BY OTHERS

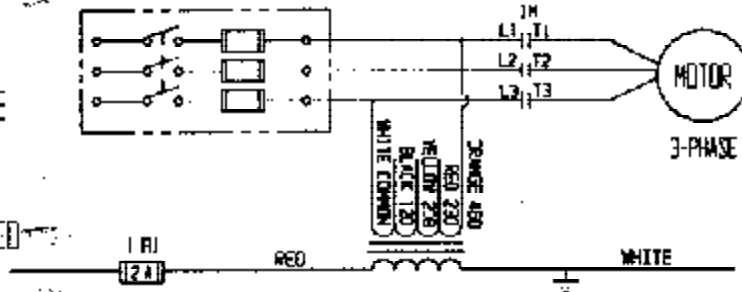

120V, 1-PHASE
FUSING AND
DISCONNECT
TO BE PROVIDED
BY OTHERS

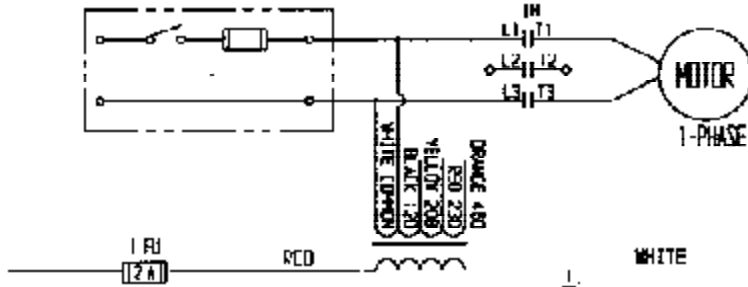

208V, 1-PHASE
FUSING AND
DISCONNECT
TO BE PROVIDED
BY OTHERS

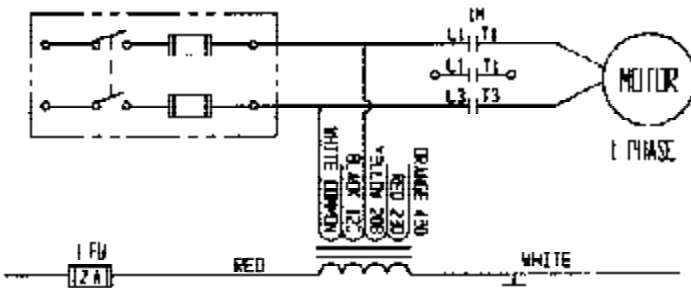

POWER CONVERSION

MOTOR LEAD CONNECTION DIAGRAM FOR ALL
 .5HP, .75HP AND 3HP SINGLE-PHASE MOTORS AND FOR
 ALL 2HP, 5.5HP, AND 6.5HP THREE-PHASE MOTORS

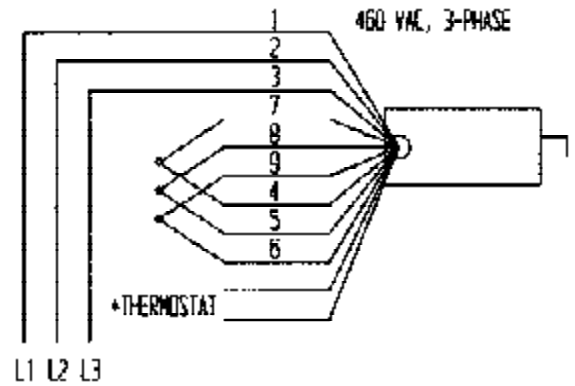
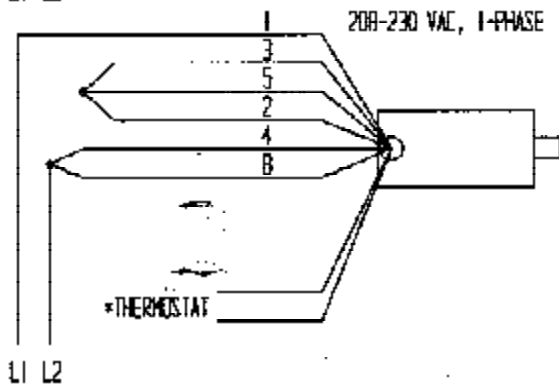
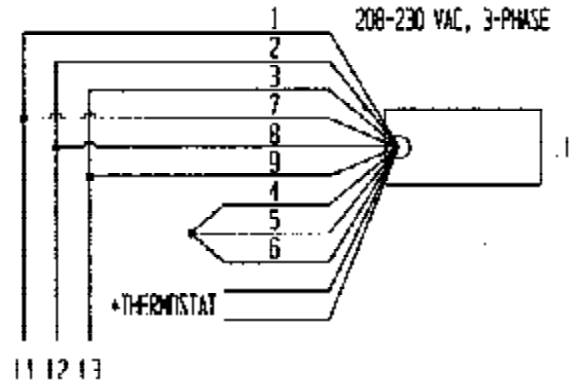
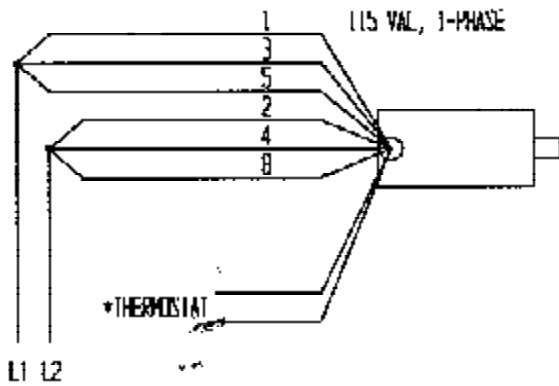

* The two thermostat leads go to: 1) the grounded side of the transformer secondary, and; 2) the motor relay coil, in either order.



BE SURE ALL POWER IS OFF BEFORE ATTEMPTING TO WORK ON THIS EQUIPMENT!

CAUTION: SERVICE WORK SHOULD BE PERFORMED ONLY BY TRAINED & QUALIFIED PERSONNEL

HYDRAULIC OPERATION

When the operator wants to raise the unit, he/she depresses the UP button. This starts the electric motor (item 3) which turns the hydraulic pump (item 4). Oil from the reservoir (item 1) is drawn in through the suction filter (item 2) and into the pump. The pump delivers the pressurized oil through the check valve (item 6) before entering the cylinders.

The function of the check valve is to allow the oil to flow in one direction, i.e. towards the cylinders. It also prevents the flow of oil back into the pump circuit when the pump stops running. This holds the oil in the cylinders and maintains the desired elevation.

If the load is excessive, and the UP button is still depressed, pressure will build up in the circuit between the pump and the cylinders. This forces the "ball" or "poppet" in the relief valve (item 5) to unseat allowing the pump out to put returns into the reservoir through the return pipe.

When the operator desires to lower the unit, he depresses the DN button. This energizes the down solenoid valve (item 8). The poppet in the solenoid valve is unseated and oil now returns from the cylinders through the flow control valve (item 9), return filter (item 13), the solenoid valve, oil return pipe, and in the reservoir.

The flow control valve (item 9) controls the down speed of the table. It is preset and cannot be changed. Releasing the DN control will de-energize the solenoid, closing the valve poppet. This prevents the oil from returning to the reservoir and the cylinders will stop retracting. The unit is now maintained at the particular elevation.

Cartridge Valves

The lowering valve, as discussed above, is of cartridge construction and is virtually maintenance free. If there is a faulty operator, check Trouble Shooting Section. To clean the cartridge valve, follow this procedure:

- 1) Use a sharp object and push poppet in from the bottom to open the valve.
- 2) Repeat several times while valve is immersed in kerosene or mineral spirits. Blow dry.
- 3) Inspect "O" rings and the teflon extrusion washer.
- 4) Reinstall. The valve should be tightened to approximately 30 ft./lbs.

Velocity Fuse

There is a brass velocity fuse with stainless steel spring in the base of each cylinder (item 10). In the event of a hydraulic pump failure, the platform starts to lower at a fast rate. As soon as the descent speed exceeds the preset speed, the velocity fuse will shut off the oil flow and the platform will remain stationary until pressure is reapplied. This safety feature reduces the possibility of accidental personal injury or damage to the table or contents. To reset the velocity fuse just activate pump by depressing the UP button.

If your table descends very slowly or will not descend at all, air is likely trapped in the hydraulic circuit and must be "bled" from the system. The Scissor Tables utilize a "bleeder" screw at the top of the cylinder near the cross tube. If you experience the above, follow these directions.

- 1.) Remove the load from the table top.
- 2.) Raise the table and install the maintenance prop.
- 3.) If available, place a 1/4" plastic hose over the cylinder "bleeder" screw and run opposite end into container.
- 4.) Loosen the bleeder screw approximately 1/4 to 1/2 turn which will allow trapped air to escape.
- 5.) When "clear" fluid runs from the plastic hose, tighten the bleeder screw and remove the plastic hose.

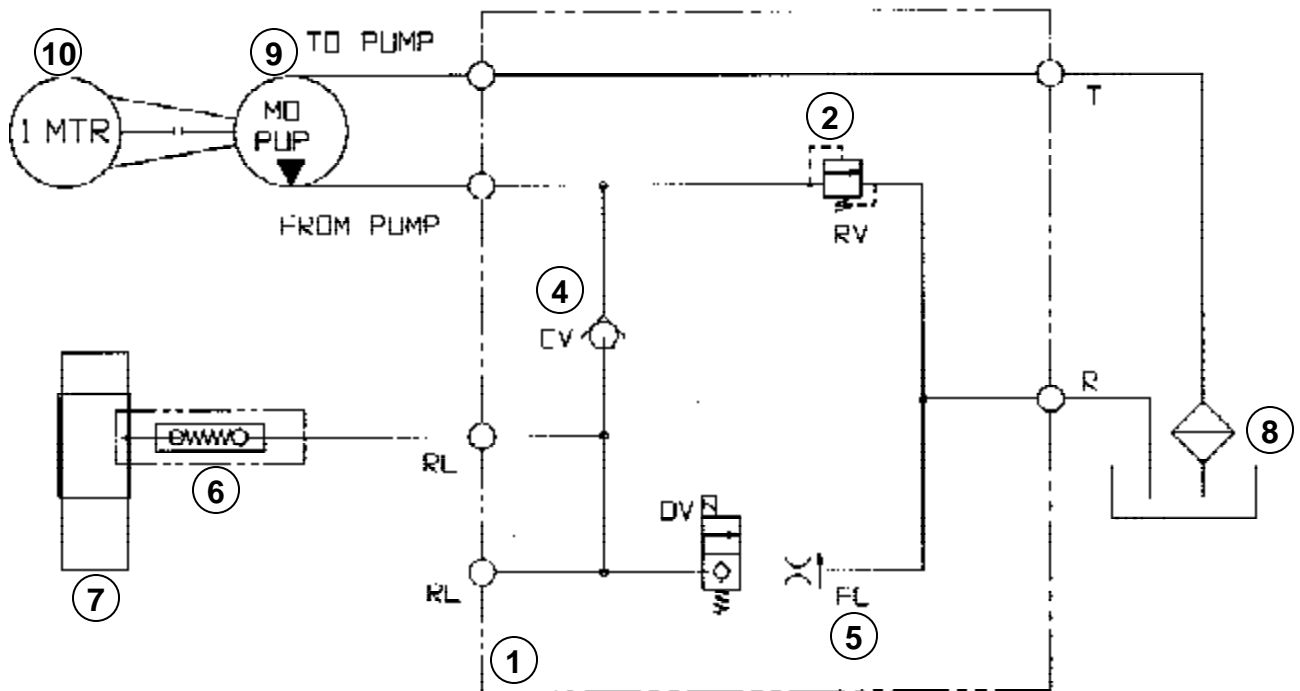

HYDRAULIC SCHEMATIC DIAGRAM

- | | |
|-----------------------|--------------------|
| 1) Hydraulic Manifold | 6) Velocity Fuse |
| 2) Relief Valve | 7) Cylinder |
| 3) Lowering Valve | 8) Suction Filter |
| 4) Check Valve | 9) Pump |
| 5) Flow Control | 10) Electric Motor |

EXPLODED PARTS DRAWING

Scissor Table - Model BEHLT

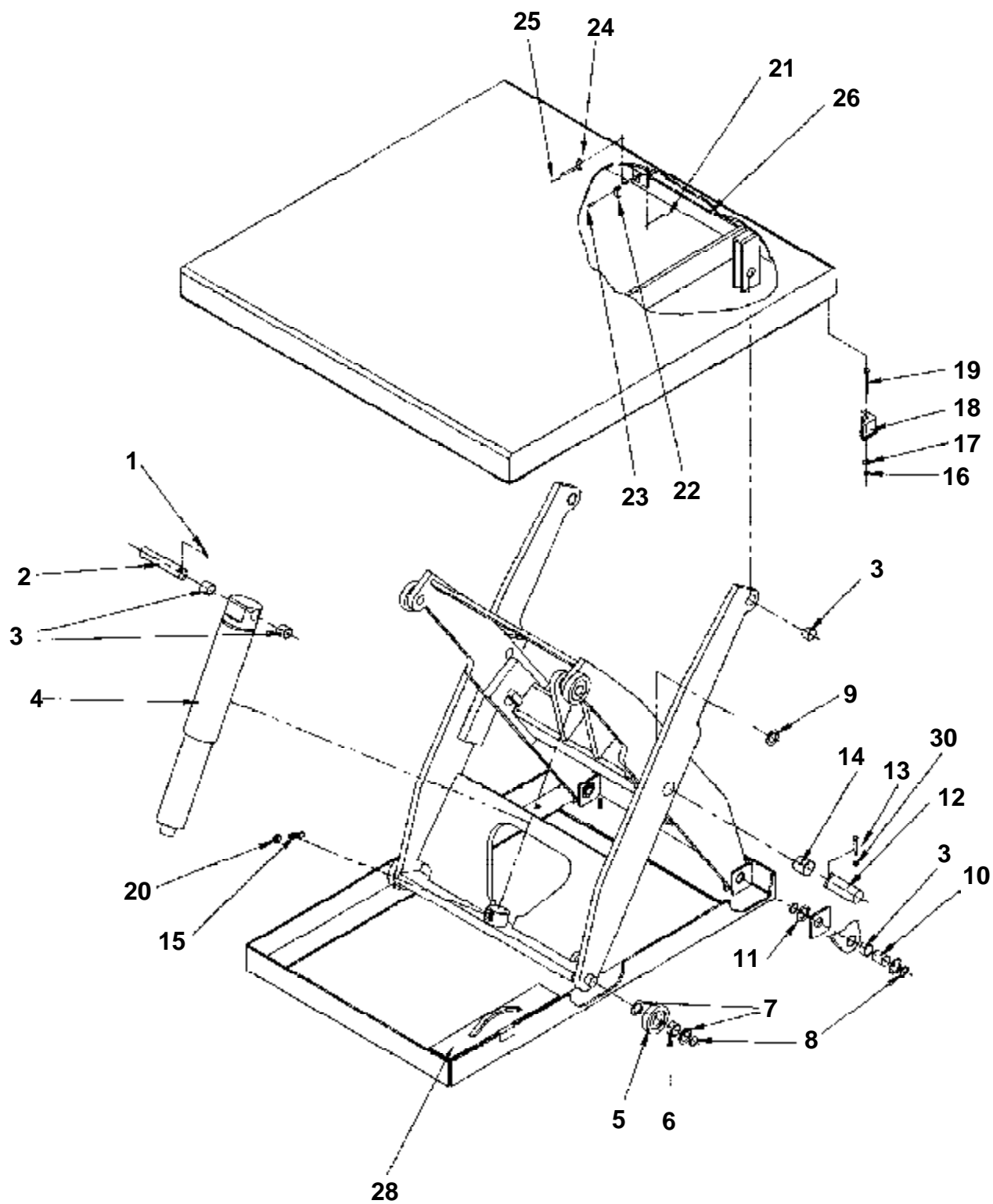

PARTS IDENTIFICATION - Scissor Table - Model BEHLT

ITEM NUMBER	DESCRIPTION	ENGINEER NUMBER	PART NUMBER	QTY
1	Pin, Roller 3/16" dia. x 1-1/8" lg.	a/l	a/l	1
2	Pin, Cylinder Pivot 1-1/8" dia.	B24-112-02	BST-CYLPIN	1
3	Bearing, Sleeve 1-1/8" dia. x 3/4" lg.	B01-111-002	BST-CYLBORG	6
4	Cylinder, Hydraulic 3" dia x 10" stk	B99-021-901	BST-CYL	1
5	Roller, 3-1/4" dia. x 3/4"w	B01-027-001	BST-RLR	4
6	Bearing, Sleeve 1-1/8" dia. x 5/8" lg.	B01-111-001	BST-RLRBRG	4
7	Washer, Thrust Bearing 1-1/8" dia. x .06 thk.	B01-115-001	BST-TRBRG	8
8	Retainer Snap Ring 1-1/8" dia. External	a/l	a/l	12
9	Washer, Thrust Bearing 1-1/2ID x .06 thk.	B01-115-003	a/l	4
10	Pin, Hinge 1-1/8 dia.	B01-112-004	BST-HP	4
11	Shim, Machinery Bushing 1-1/8" ID x .06 thk.	a/l	a/l	4
12	Pin, Scissors Pivot 1-1/2" dia.	B01-112-019	BST-SPP	2
13	Bolt, Shoulder 3/8" dia. x 1-1/2" lg.	a/l	a/l	2
14	Bearing, Sleeve 1-1/2" dia x 1-1/2" lg.	B01-111-003	BST-BRG	2
15	Bolt, Cylinder Retainer	B01-118-001	BST-CRB	1
16	Nut, Hex Nylock 1/4-20 unc	a/l	a/l	4
17	Washer, Flat 1/4 nom ID	a/l	a/l	4
18	Toe Guard Support	B01-015-009	BST-TGCNR	4
19	Screw, Hex HD 1/4-20 unc x 2-1/2" long	a/l	a/l	4
20	Nut, Hex Jam 1/2-13 unc	a/l	a/l	1
21	Screw, #8-32 x 1/2 lg Flat HD Socket Cap	a/l	a/l	2
22	Toe Guard Actuator	B01-015-008	BST-TGA	2
23	Specialty Hardware, Toeguard	B01-145-010	BST-HDW	2
24	Switch, Electrical Limit N.C.	B01-022-022	BST-LS	2
25	Screw, #4-40 x 1/2 lg. Button Head Sock Cap	a/l	a/l	4
26	Toe Guard End L-Shaped	B01-015-912	BST-TGAE	2
27	Toe Guard Side L-Shaped	B01-015-912	BST-TGAE	2
29	Shim, Machinery Bushings 1-1/2" dia. x .06 thk	a/l	a/l	2
30	Nut, Hex Nylock 5/16-18 unc	a/l	a/l	2

****PLEASE SUPPLY SERIAL NUMBER AT TIME OF ORDER****

HYDRAULIC EQUIPMENT

Trouble Shooting Quick Reference Guide
(For further information contact the factory)

****BEFORE PREFORMING ANY MAINTENANCE WORK ALWAYS INSTALL MAINTENANCE SAFETY BLOCKS****

Observation	Possible Cause	Remedy
1.) Table does not raise but pump is running or humming.	<p>a. Motor may be single phasing (humming) if three phase unit.</p> <p>b. Voltage at motor terminals may be too low to run pump at existing load.</p> <p>c. Hose or hydraulic line is leaking.</p> <p>d. Fluid level in reservoir is low.</p> <p>e. Load exceeds capacity requirements. Relief Valve is bypassing the fluid back into the reservoir.</p> <p>f. Suction filter is clogged, starving pump.</p> <p>g. Suction line may be leaking air, due to loose fittings.</p> <p>h. Filler/Breather cap on tank may be clogged.</p> <p>i. Down Valve may be energized by faulty wiring or stuck open.</p> <p>j. Hydraulic pump may be inoperative.</p>	<p>a. Check wiring and overloads, fuses, etc. As certain that all 3 phase lines are present at the motor.</p> <p>b. Measure voltage at motor terminals or as near as possible, while pump is running under load. If voltage is sufficient, check for inadequate or incorrect wiring as this can starve the motor. (Refer to chart in Owner's Manual for recommendations.) Correct as necessary.</p> <p>c. Correct as necessary.</p> <p>d. Add fluid. Refer to Owner's Manual for proper fluid levels.</p> <p>e. DO NOT CHANGE RELIEF VALVE SETTING. Instead, reduce the load to rated capacity.</p> <p>f. Remove and clean.</p> <p>g. Inspect all fittings for proper fit.</p> <p>h. Remove and clean.</p> <p>i. Remove Solenoid Valve. Check and clean. (Refer to Hydraulic Section of Owner's Manual).</p> <p>j. Disconnect hydraulic line at power unit. Put pressure line in a large container and cycle pump. If no output, check the pump motor coupline, which may be defective, and correct as necessary. If pump is worn, consult factory for replacement parts service.</p>
2.) Table raises too slowly.	<p>a. Foreign material stuck in Down Solenoid, causing some fluid to bypass back into tank.</p> <p>b. Foreign material clogging suction filter, breather cap, or a pinched hose.</p> <p>c. Low motor voltage.</p> <p>d. Table overloaded.</p> <p>e. Pump is inoperative.</p>	<p>a. Lower the platform. Remove the Solenoid Valve and clean. (Refer to Hydraulic Section of Owner's Manual).</p> <p>b. Correct as necessary. (See also, 1 (f), (h)).</p> <p>c. See 1 (b).</p> <p>d. See 1 (e).</p> <p>e. See 1 (j).</p>
3.) Motor labors, or is excessively hot.	<p>a. Voltage may be low.</p> <p>b. Incorrect wiring.</p> <p>c. Oil starvation causes pump to bind. High internal heat is developed. If this occurs, pump may be permanently damaged.</p> <p>d. Binding cylinders.</p>	<p>a. See 1 (b).</p> <p>b. Check that one leg of the motor lines is not connected to ground.</p> <p>c. See 1 (d), (f), (g), (h), (j).</p> <p>d. Align cylinders correctly.</p>
4.) "Spongy" or "Jerky" table operation. Do not confuse spongy operation with small surges caused by foreign material on table wheel roller plate.	<p>a. Fluid starvation.</p> <p>b. Air in system.</p>	<p>a. See 1 (d), (f), (g), (j).</p> <p>b. See air bleed procedure p.9.</p>
5.) Table lowers to slowly when loaded.	<p>a. Down Valve filter clogged.</p> <p>b. Pinched tube or hose.</p> <p>c. Foreign material in Flow Control Valve.</p> <p>d. Binding cylinders</p> <p>e. Foreign material in Velocity Fuse.</p>	<p>a. Remove Solenoid Valve and clean filter.</p> <p>b. Correct as necessary. (In case of pipe, check for obstruction in line.)</p> <p>c. Remove and clean Flow Control Valve. (Refer to Hydraulic Section of Owner's Manual).</p> <p>d. Align cylinders correctly.</p> <p>e. Remove and clean Velocity Fuse. (Refer to Hydraulic Section of Owner's Manual.)</p>

Observation	Possible Cause	Remedy
6.) Table lowers too quickly.	a. Leaking hoses and/or cracked fittings.	a. Correct as necessary.
	b. Check valve is stuck open. (The combination of a stuck Check Valve and open Solenoid Valve will cause excessive speeds.)	b. Remove and clean Check Valve. (Refer to Hydraulic Section of Owner's Manual).
	c. Foreign material stuck in Flow Control Valve. (In this case, table lowers initially at a normal rate then speeds up as the platform descends.)	c. Remove Flow Control Valve from the Valve Block and clean. (Refer to Hydraulic Section of Owner's Manual).
7.) Table raises then lowers slowly.	a. Down Solenoid Valve may be incorrectly wired or is stuck open due to dirt.	a. See 2(a).
	b. Check Valve may be stuck open.	b. Remove and clean Check Valve. (Refer to Hydraulic Section of Owner's Manual).
	c. Check for leaking hoses, fittings, pipes.	c. Correct as necessary.
	d. Cylinder packings may be worn or damaged.	d. Replace packings. (Consult Factory for replacement parts.)
8.) Table has raised, but does not lower.	a. Blown electrical fuse.	a. Check and replace.
	b. Incorrect Down Solenoid Valve wiring.	b. Correct as necessary. (Refer to Electrical Section of Owner's Manual.)
	c. Down Solenoid Valve is stuck.	c. Lightly tap down the Solenoid Coil body to seat it properly. (DO NOT hit coil hard as it will permanently damage the internal stem). DO NOT remove the Solenoid Valve from the Block as the unit will come down at a dangerous speed.
	d. Faulty Down Solenoid Coil.	d. Remove and replace. (Refer to Electrical Section of Owner's Manual.)
	e. Maintenance safety props, or some other object blocking down travel.	e. Raise table and remove the safety props, or whatever object is blocking the down travel, then press the down button.
	f. Binding cylinders.	f. See 2(e).
	g. In case of excessive down speeds, the Velocity Fuse will become operative and shut off the oil flow from the cylinders, thus the platform will remain stationary.	g. To unlock, re-pressurize the hydraulic system. Refer to velocity fuse section.
	h. The perimeter pinch point guard switch(es) could be engaged.	h. Remove obstacle from under tables edge; adjust guard height at corners of platform if necessary.

LIMITED WARRANTY

ONE YEAR LIMITED WARRANTY. The manufacturer warrants for the original purchaser against defects in materials and workmanship under normal use one year after date of purchase. (Not to exceed 15 months after date of manufacture.) Any part which is determined by the manufacturer to be defective in material or workmanship and returned to the factory, shipping costs prepaid, will be, as the exclusive remedy, repaired or replaced at our option. Labor costs for warranty repairs and/or modifications are not covered unless done at manufacturer's facilities. Any modifications performed without written approval of the manufacturer may void warranty. This limited warranty gives purchaser specific legal rights which vary from state to state.

LIMITATION OF LIABILITY. To the extent allowable under applicable law, the manufacturer's liability for consequential and incidental damages is expressly disclaimed. The manufacturer's liability in any event is limited to, and shall not exceed, the purchase price paid. Misuse or modification may void warranty.

WARRANTY DISCLAIMER. Our company has made a diligent effort to illustrate and describe the products shown accurately; however, such illustrations and descriptions are for the sole purpose of identification, and do not express or imply a warranty that the products are merchantable, or fit for a particular purpose, or that the products will necessarily conform to the illustrations or descriptions.

The provisions of the warranty shall be construed and enforced in accordance with the UNIFORM COMMERCIAL CODE and laws as enacted in the State of Indiana.

DISPOSITION. Our company will make a good faith effort for prompt correction or other adjustment with respect to any product which proves to be defective within the Limited Warranty. Warranty claims must be made in writing within said year.

POWER UNIT SPECIFICATIONS

Electric Motor:

- 2 Hp intermittent duty, 1 Hp continuous duty
- 230/460V 3-phase or 110/220V 1-phase, 60 Hz
- 56 Frame

Voltage	Amp Draw
110 1-phase	22
220 1-phase	11
230 3-phase	7.6
460 3-phase	3.8

Pump:

- Cast iron construction
- Integrated valve circuit
- 1 G.P.M. flow rate @ 1725 rpm

- 1) 56 Frame, 2 Hp Motor
- 2) Hydraulic Pump with Integrated Circuit
- 3) Down Solenoid Coil
- 4) Solenoid Cartridge Valve
- 5) Fused Step Down Transformer
- 6) Motor Contactor

Safety Yellow Electrical wire

- 8) Upper Travel Limit Switch

Item No.	Part No.	Description
1	ST-M	MOTOR
2	ST-PMP	PUMP
3	ST-SC	SOLENOID COIL
4	ST-SV	SOLENOID CARTRIDGE VALVE
5	ST-TF	TRANSFORMER
6	ST-MC	MOTOR CONTACTOR
7	ST-JB	JUNCTION BOX
8	ST-LS	LIMIT SWITCH
9	ST-PMPSK	PUMP SEAL KIT
10	ST-SVSK	VALVE SEAL KIT

Routine Maintenance & Safety

Raise the table and install the Maintenance Safety Prop before beginning any inspection or work on the unit.

(A) Before Each Use Check For The Following:

- 1.) Frayed wires
- 2.) Oil leaks
- 3.) Pinched or chafed hoses
- 4.) Structural deformation of arms, frame, and platform
- 5.) Unusual noise or binding
- 6.) Proper functioning of all limit switches

Do not use if there are any of the above!

(B) Monthly Inspections

- 1.) Check oil level. Oil should be 1" below the tank's fill hole with the lift in the fully raised position. Add as necessary.
- 2.) Check for oil leaks. See trouble shooting section and correct as necessary.
- 3.) Check roller bushings, axle pin, clevis and pivot points for wear.
- 4.) Check for worn or damaged hydraulic hoses, electrical wires, and cords. Repair as necessary.
- 5.) Check rollers for looseness and wear. See trouble shooting.
- 6.) Check retaining rings at all axles, pivot points and clevis.
- 7.) Check for unusual noise. See trouble shooting.
- 8.) Make sure all warning labels are in place and in good condition.
- 9.) Clean off dirt and debris.

(C) Yearly

Oil reservoir should be changed at least once a year, or sooner if the oil darkens or becomes gritty. Presence of water is indicated if the oil turns milky. Recommended oil: AW-32 or Ho150 hydraulic fluid Dextron II or III transmission fluid, or equal.

All maintenance work must be preformed by qualified personnel with training in the repair of electrical and hydraulic components.

WARNING LABEL IDENTIFICATION

MAKE SURE ALL WARNING LABELS ARE IN PLACE!

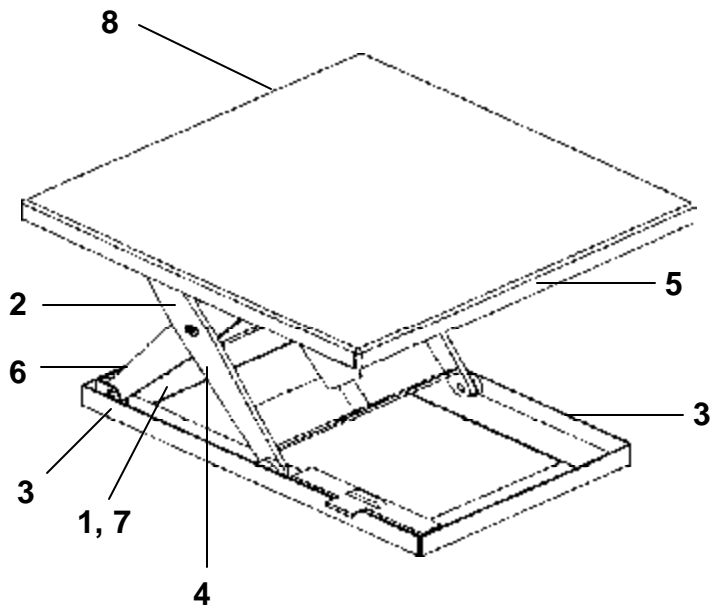

NOTE:

Labels 1 & 7 are located on junction box cover

①

NOTICE	NOTA	AVIS
POWER SUPPLY: 115 Volt/1 Phase/60 HZ		
CONTROL VOLTAGE: 24 VOLT AC		
CORRIENTE: 115 Volt/1 Fase/60 HZ		
VOLTAJE DE CONTROL: 24 VOLT CA		
ALIMENTATION ÉLECTRIQUE: 115 Volt/1 Phase/ 60 HZ		
VOLTAGE DE CONTRÔLE: 24 VOLT AC		

248

②

ON HYDRAULIC TANK (NOT SHOWN)

ISO AW-32
HYDRAULIC OIL OR EQUIVALENT
ACEITE HIDRÁULICO O EQUIVALENTE
HYDRAULIQUE OU ÉQUIVALENT

206

*Product safety signs or labels should be periodically inspected and cleaned by the product users as necessary to maintain good legibility for safe viewing distance . . . ANSI 535.4 (10.21)
Contact manufacturer for replacement labels if needed.

③

⚠ WARNING	⚠ AVISO	⚠ AVERTISSEMENT
SECURE FRAME TO FLOOR	ASEGURE EL BASTIDOR AL PISO	FIXER SOLIDEMENT LE CADRE AU PLANCHER

204

④

⚠ WARNING	⚠ AVISO	⚠ AVERTISSEMENT
KEEP CLEAR WHEN IN USE	MANTENGASE ALEJADO CUANDO SE ESTA OPERANDO	SE TENIR À DISTANCE LORS DU FONCTIONNEMENT

220

⑦

DANGER ⚠	SHUT POWER OFF AND CONSULT OWNERS MANUAL BEFORE WORKING ON THIS EQUIPMENT
PELIGRO ⚠	CORTE LA CORRIENTE Y CONSULTE EL MANUAL DEL PROPIETARIO ANTES DE TRABAJAR EN ESTE EQUIPO
DANGER ⚠	COUPER LE COURANT ET CONSULTER LE MANUEL D'UTILISATION AVANT DE TRAVAILLER SUR CET ÉQUIPEMENT.

221

⑤

BOTH SIDES & FRONT END		
⚠ WARNING	⚠ AVISO	⚠ AVERTISSEMENT
KEEP CLEAR OF PINCH POINT	MANTENGASE ALEJADO DE PUNTO DE CORTE	SE TENIR À DISTANCE DU POINT DE PINCEMENT

208

⑥

FOR USER INSTRUCTIONS OR QUESTIONS CONTACT
PARA INSTRUCCIONES DE USO Ó CONSULTAS CONTACTAR
POUR INSTRUCTIONS OU QUESTIONS SUPPLÉMENTAIRES CONTACTER

205

⑧

DANGER ⚠	TO AVOID PERSONAL INJURY READ OWNER'S MANUAL BEFORE OPERATING OR REPAIRING SCISSOR LIFT		DO NOT PUT HANDS, FEET OR OBJECTS UNDER TOP. LOWER PLATFORM SLOWLY.		DO NOT WORK UNDER LIFT WITHOUT SAFETY BLOCK OR WHILE LOADED. KEEP CLEAR OF MOVING SCISSOR LEG MECHANISM.		DO NOT STAND, SIT OR RIDE ON LIFT
PELIGRO ⚠	PARA EVITAR DAÑOS PERSONALES LEA EL MANUAL DEL PROPIETARIO ANTES DE OPERAR O REPARAR EL ELEVADOR DE TIJERAS		NO PONGA MANOS, PIES U OBJETOS DEBAJO DEL BORDE. DESCENDA LA PLATAFORMA LENTAMENTE.		NO TRABAJE DEBAJO DEL ELEVADOR SIN LOS FRENOS DE SEGURIDAD O CUANDO ESTE CARGADO. MANTENGASE ALEJADO DEL MECANISMO DE TIJERA EN MOVIMIENTO.		NO SE SIENTE, SE PARE, O VIAJE EN EL ELEVADOR
ATTENTION ⚠	POUR ÉVITER TOUTE BLESSURE PERSONNELLE LIRE LE MANUEL D'UTILISATION AVANT DE METTRE EN MARCHÉ OU AVANT DE RÉPARER L'ÉLEVATEUR CISEAU		NE PAS METTRE LES MAINS, LES PIEDS OU TOUT OBJET SOUS LE PLATEAU SUPÉRIEUR. DESCENDRE LA PLAT-FORM LENTEMENT		NE PAS TRAVAILLER SOUS L'ÉLEVATEUR SANS BLOCS DE SÉCURITÉ OU LORSQU'IL EST CHARGÉ. RESTER À L'ÉCART DU MÉCANISME CISEAU LORSQUE L'ÉLEVATEUR EST EN FONCTIONNEMENT.		NE PAS SE TENIR DEBOUT, S'ASSEOIR OU MONTER SUR L'ÉLEVATEUR

207