

Ergonomic Solutions

OWNER'S MANUAL

MECHANICAL POST TABLE • MODEL BMT

Contents

Warning & Safety Instructions	1	Mechanical Post Table Parts List	3-4
Receiving Instructions	1	DC Powered Post Table Parts List	5-6
Warranty	1	Trouble Shooting Guide	7
Ordering Replacement or Extra Parts	2	Electrical Diagram	7
Installation Instructions	2	Battery Charger Operating Instructions	8
Operating Instructions	2		

WARNINGS & SAFETY INSTRUCTIONS

Read owner's manual completely before operating unit!

- Not a personnel lift.
- Remove weight & disconnect power before working on unit.
- Use only maintenance parts supplied or approved by the manufacturer.
- Never operate the lift unless you are watching it.
- Transport loads in the lowered position only.
- Don't continue to operate the control if unit is not moving.
- Consult factory before adding or performing any modification to the original equipment.

RECEIVING INSTRUCTIONS

Every unit is thoroughly tested and inspected prior to shipment. However, it is possible that the unit may incur damage during transit. If you see damage when unloading make a note of it on the SHIPPER RECEIVER.

Remove all packing and strapping material, inspect for damage. IF DAMAGE IS EVIDENT, FILE A CLAIM WITH THE CARRIER IMMEDIATELY! Also, check the unit size, type of power unit, etc., to ensure the unit is correct for the intended application.

WARRANTY

This product is warranted for 1 YEAR from date of purchase to be free of manufacturing defects in material and workmanship. The manufacturer's obligation hereunder is limited to either providing replacement parts or repairing the product, provided the product is sent prepaid back to the factory.

This warranty does not cover normal wear of parts or damage resulting from any of the following: negligent use or misuse of the product, use or application contrary to installation

instructions, or disassembly, repair or alteration by any person prior to authorization from a factory representative.

ORDERING REPLACEMENT OR EXTRA PARTS

Our company takes pride in using the finest available parts for our equipment. We are not responsible for equipment failure resulting from the use of unapproved replacement parts. To order replacement or extra parts for your equipment contact Customer Service at the factory. In any correspondence with the factory please include the **Serial Number** which is inscribed on the nameplate of the piece of equipment. Use only the part numbers provided in this Owner's Manual. When ordering parts for AC power units please indicate the motor phase and voltage that the equipment is operating on.

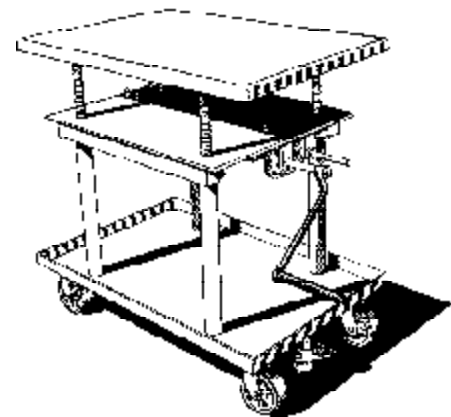

**MECHANICAL POST TABLE
MODEL BMT**

INSTALLATION INSTRUCTIONS

INSTALLING CASTERS (fig. 1)

- 1.) Two 5" dia. swivel casters are installed on one end of base frame (handle end of platform) and 5" dia. rigid casters are installed on other end.
- 2.) Place the caster base plate into the caster pad bracket (located on the bottom of frame).
- 3.) Insert 3/8" x 16 UNC x 5" long carriage bolt through the square hole in the caster pad to hold the caster in place.
- 4.) Place 3/8"-16 UNC lock nut on each bolt and tighten securely.

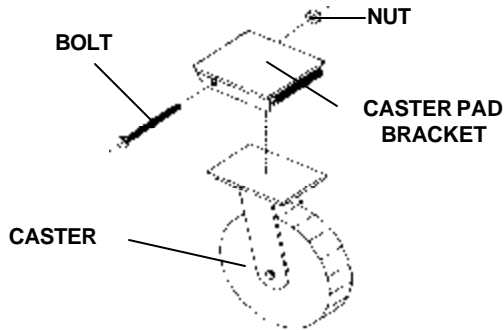

Figure 1

INSTALLING FLOOR LOCK - (fig. 2)

- 1.) Align mounting plate of floor lock with predrilled holes on bottom of frame.
- 2.) Install floor lock with foot pedal bracket facing out.
- 3.) Insert four 3/8"-16 x 1" long hex head cap screws through top of frame.
- 4.) Place four 3/8" - 16 lock nuts on each bolt and tighten securely.

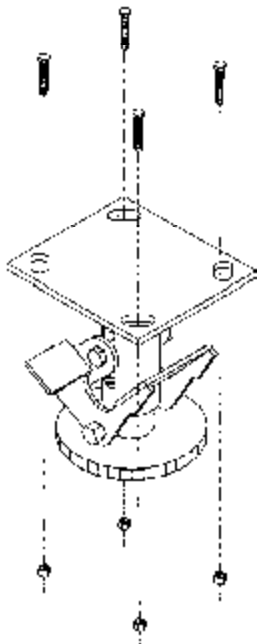

Figure 2

OPERATING INSTRUCTIONS

MANUAL HAND CRANK

Attach hand crank. Turn clockwise to raise unit and counter clockwise to lower unit.

DC POWERED

Position of the deck is controlled by the hand-held pendant control. The arrows display direction of travel of deck.

In order to operate the unit, pressure must be maintained in the UP or DOWN position to raise or lower deck. On releasing either button, the deck will remain at that particular position until the button is depressed again.

RESPONSIBILITIES OF OWNERS/USERS

It is the responsibility of the owner/user for the following:

- 1.) The lift must be inspected and maintained in accordance with the guidelines in this manual.
- 2.) Any lift not in safe operating condition must be removed from service until it is returned to proper operating condition.

Unsafe condition may include, but is not limited to the following: missing rollers, pins, or fasteners, any cracked or deformed structural members, cut or frayed electric lines, and damaged controls or safety devices.

All repairs and maintenance must be performed by qualified personnel.

- 3.) Lift may only be used by authorized personnel. All lift operators must have read and understood all operating procedures and safety guidelines in this Owner's Manual.
- 4.) Lift must never be overloaded.
- 5.) Operator must ensure that all safety features of the lift are functioning properly before each use.
- 6.) Any modifications to the lift must be approved in writing by the manufacturer.

PARTS IDENTIFICATION MECHANICAL POST TABLE • MODEL BMT

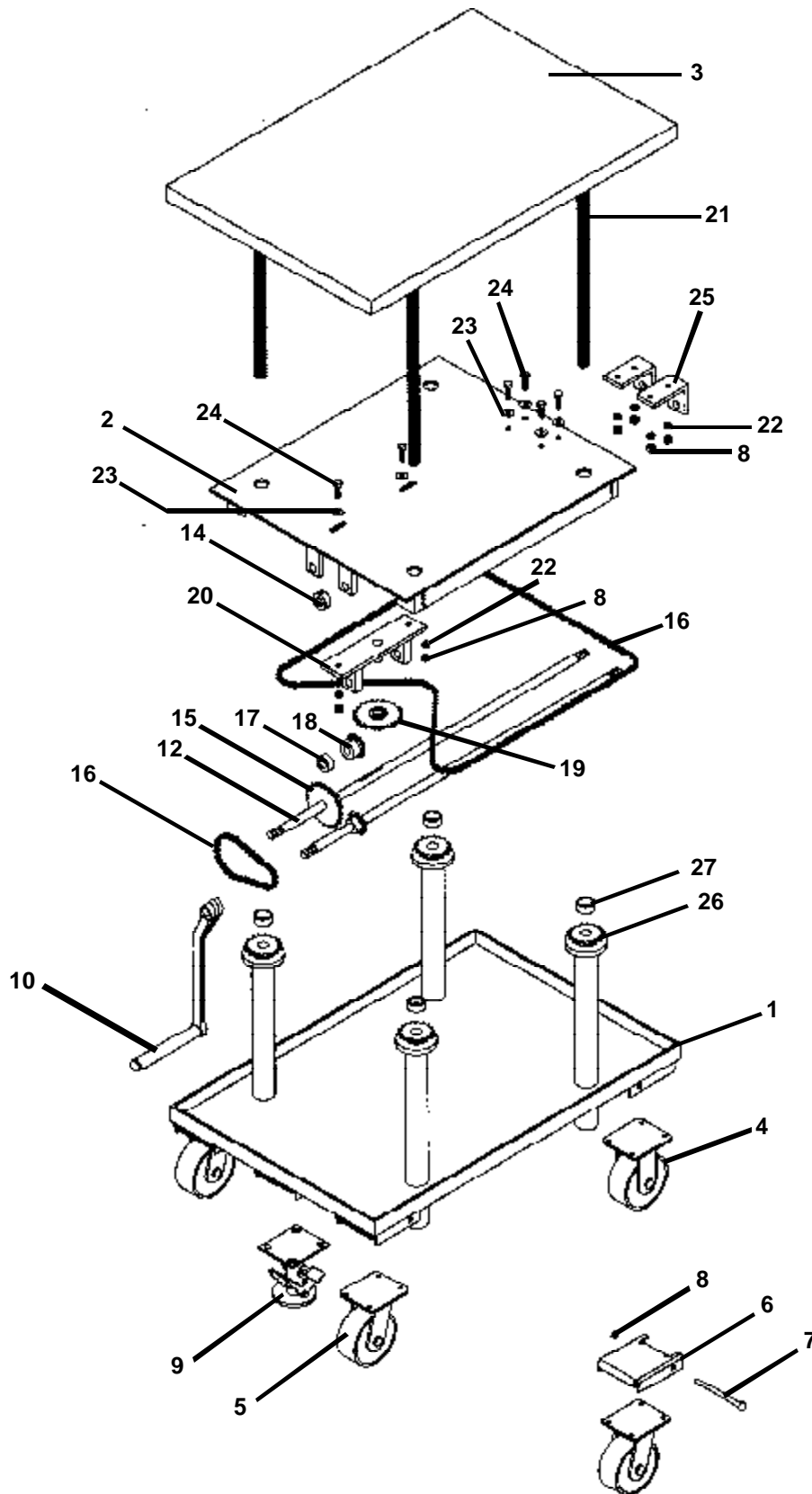

**PARTS IDENTIFICATION
MECHANICAL POST TABLE • MODEL BMT**

ITEM NO.	DESCRIPTION	ENGINEER NO.	QTY.
1	Frame, Base Sub-Assy, MT	B21-514-023/030	1
2	Deck, Center Plate (weldment), MT	B21-513-009	1
3	Deck, Table Top, MT	B21-013-024/027	1
4	Caster, Rigid, 5 x 2 poly on steel	B16-132-022	2
5	Caster, Swivel, 5 x 2 poly on steel	B16-132-021	2
6	Bracket, Caster Mount (bulldog)	B16-132-076	4
7	Bolt, Carriage, 3/8 - 16 UNC x 5 Lg.	n/a	4
8	Nut, Hex, 3/8 - 16 UNC	n/a	10
9	Foot Lock	B16-132-080	1
10	Crank Handle	B14-025-001	1
11	Shaft, Slow Speed Gear, MT	B14-026-004/006	1
12	Shaft, High Speed Gear, MT	B14-026-007/009	1
13	Sprocket, #41 Chain (12 teeth)	B21-042-007	1
14	Shaft collar, Split Shaft, with set screw 3/4"	n/a	1
15	Sprocket #41 Chain (24 teeth)	B21-042-006	1
16	Chain, Roller	B21-042-011	2
17	Spacer, High Speed Shaft	B21-113-024	1
18	Gear, Bevel	B21-042-005	1
19	Gear Ass'y, Bevel and Sprocket	B21-542-001	1
20	Bracket, Sub-Ass'y, Tension Adjust, MT	B21-516-001	1
21	Specialty Hardware, Lifting Thread	B14-145-006	4
22	Washer, Lock, 3/8 Diameter	n/a	6
23	Washer, Flat, 7/16 Diamter	n/a	6
24	Bolt, HHCS, 2/8 - 16 UNC x 1-1/4 Lg.	n/a	6
25	Bracket, Removable Shaft Mtg.	B21-016-026	2
26	Sprocket, Lifting, Post Crank	B14-042-003	4
27	Spacer, Diameter 1-1/2 x 5/32 Wall x 5/8 Lg.	B21-113-023	4

n/a - Not Available

PARTS IDENTIFICATION
MECHANICAL POST TABLE DC POWER • MODEL BMT-DC

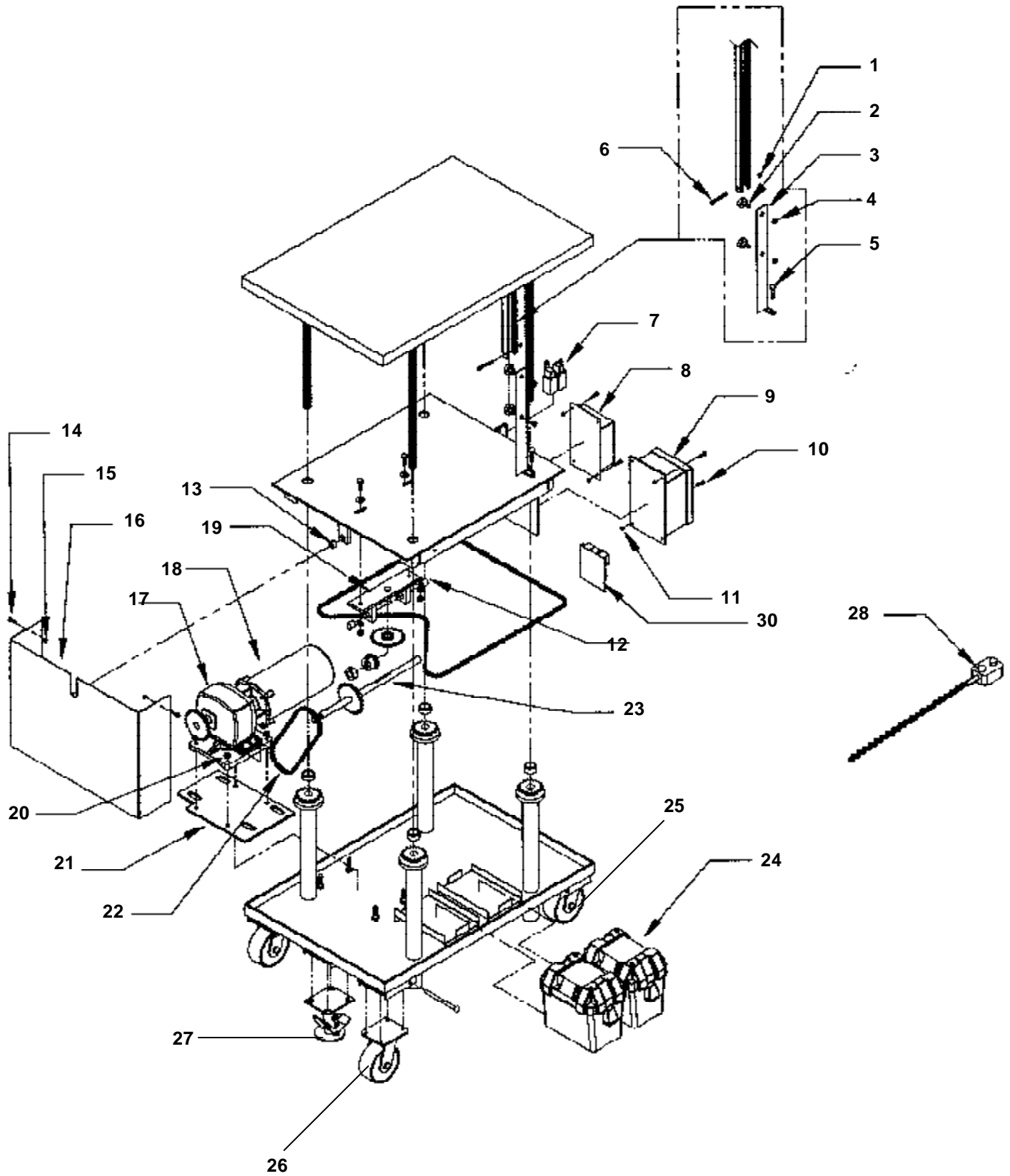

PARTS IDENTIFICATION
MECHANICAL POST TABLE DC POWER • MODEL BMT-DC

ITEM NO.	DESCRIPTION	ENGINEER NO.	PART NO.	QTY.
1	1/4 - 20 UNC Hex Nut	B36102	BMTDC-HXNT	1
2	Bearing, Roller (SWA-48 PMO)	B20-110-008	BMTDC-BRLR	2
3	Travel Bar Locator Weldment	B21-516-004	BMTDC-TBLW	1
4	5/16 - 18 UNC Lock Nut	B37021	BMTDC-LN516	2
5	Elevator Bolt 1/4 x 20 x 1-3/4 lg.	B22805 (Fastenal)	BMTDC-EVBLT	1
6	HHCS 1/4-20 UNC x 2-1/2 lg.	B11013	BMTDC-11013	1
7	Roller Arm Limit Switch	B01-022-001	BMTDC-RALS	2
8	Guest Battery Charger	B21-034-001	BMTDC-GBC	1
9	6 x 8 Control Box	B01-029-007	BMTDC-CB68	1
10	1/4 - 20 UNC x 1 lg.	B11005	BMTDC-11005	4
11	1/4 - 20 UNC Hex Nut	B36102	BMTDC-HXNT	4
12	Bushing Sleeve 3/4 x 3/4 lg.	B01-111-009	BMTDC-BS34	2
13	Bushing Sleeve 3/4 x 1/2 lg.	B01-111-008	BMTDC-BS12	1
14	1/4 - 20 UNC x 1 lg.	B11005	BMTDC-11005	2
15	1/4 - 20 UNC Hex Nut	B36102	BMTDC-HXNT	2
16	Safety Shroud, Chain Cover	B21-024-020	BMTDC-SSCC	1
17	Reducer, Hub city (SWA-48)	B20-141-002	BMTDC-HCR	1
18	DC Motor (1 hp) (PEL-400)	B21-641-001	BMTDC-DCMTR	1
19	Brkt. Weldment, Tension Adj.	B21-516-005	BMTDC-TAWB	1
20	1/2 x 13 UNC Hex Nut	B36109	BMTDC-36109	4
21	Brkt. Motor Base	B21-016-064	BMTDC-MTRBS	1
22	Chain RC-41 (MT-2436)	B21-042-001	BMTDC-CHAIN	1
23	ShaftGear	B21-026-005	BMTDC-SFTGR	1
24	Battery (w/case) (PEL-400)	B21-139-002	BMTDC-BAT	2
25	Rigid Caster 5" x 2"	B16-132-022	BMTDC-5X2PRC	2
26	Swivel Caster 5" x 2"	B16-132-021	BMTDC-5X2PSC	2
27	Floor Lock	B16-132-080	BMTDC-FL	1
28	Hand Control with Coil Cord	B01-022-015	BMTDC-HNDCNT	1
29	Circuit Breaker (not shown)	B21-146-001	BMTDC-CB	1
30	Motor Controller	B21-156-003	BMTDC-MTRCONT	1

Troubleshooting Quick Reference Guide for DC Powered Mechanical Post Table

(For further information contact the factory)

WARNING! BEFORE PERFORMING ANY MAINTENANCE WORK ALWAYS UNLOAD UNIT AND INSTALL MAINTENANCE SAFETY BAR(S)

Observation	Possible Cause	Remedy
1.) Power unit does not run when hand control is operated.	a. Battery voltage low. b. Bad wiring connection / broken wire in circuit. c. Problem with motor / control.	a. Charge battery. b. Visually inspect wires, do continuity checks with meter. Refer to electrical diagram. c. Consult factory.
2.) Motor hums, platform would not move.	a. Chain / master link broken. b. Obstruction / jamed chain.	a. Inspect and replace if necessary. b. Inspect chain, rollers, roller track and pully assembly.
3.) Unit turns off before reaching the fully raised or lowered height.	a. Battery voltage low. b. Platform roller bearing obstructed or is binding. c. The "platform raised" limit switch engaging too soon, or is bad (where applicable). d. Wire inside control cable broken. e. Platform overloaded.	a. Charge battery. b. Inspect roller track for interference or damage. c. Adjust the limit switch pully spring's tension: test switch with meter. d. Rotate control around while pressing button(s). If the unit operates intermittently, change the control. e. Check load; reduce if necessary.

ELECTRICAL DIAGRAM WITH 24 VDC POWER OPTION

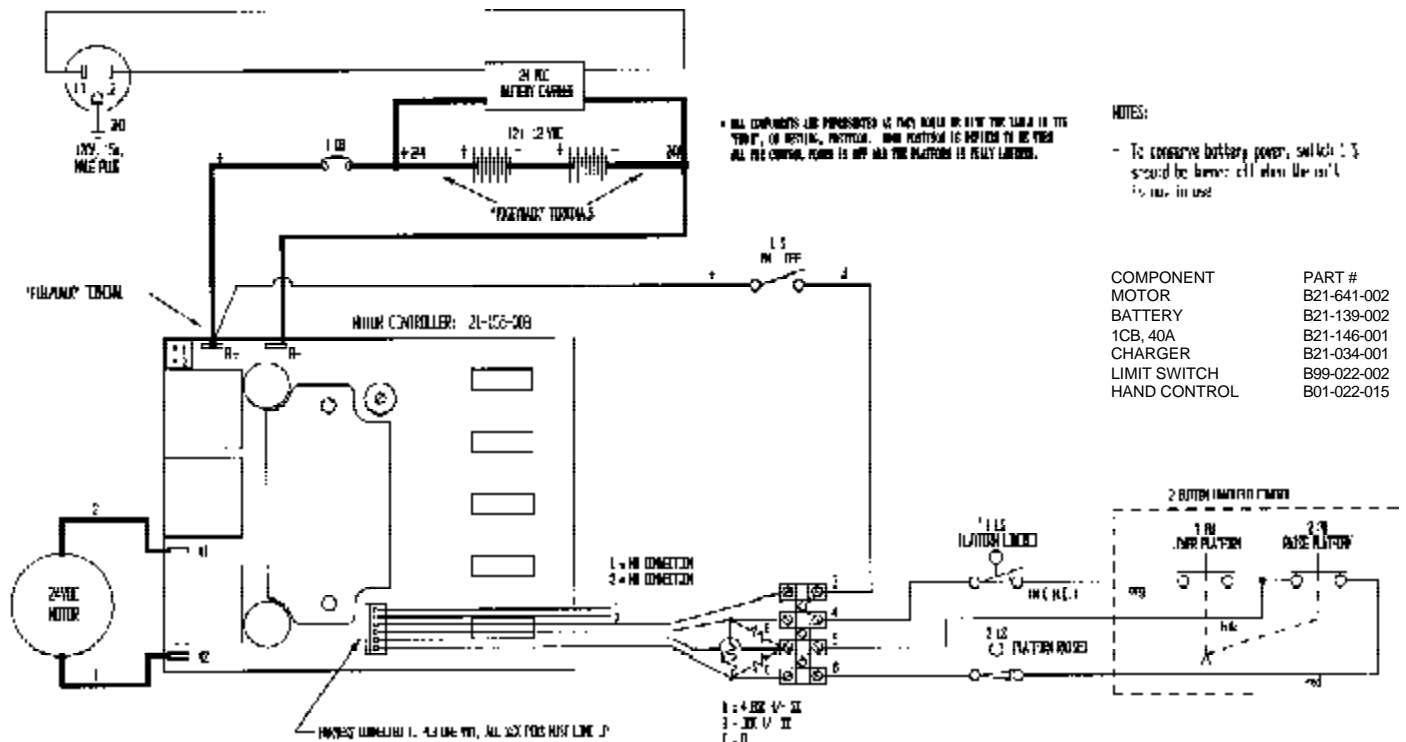

OPERATING INSTRUCTIONS FOR ON-BOARD STYLE BATTERY CHARGER

WARNING!

Working with or near lead acid batteries is dangerous. Batteries contain sulfuric acid and produce explosive gases. A battery explosion could result in loss of eyesight or serious burns.

Do not smoke or allow a spark or flame near batteries. Charge batteries in locations which are clean, dry and well ventilated. Do not lay tools or anything metallic on top of any battery. All repairs to a battery must be made by experienced and qualified personnel.

When working with batteries, remove personal items such as rings, bracelets, necklaces, and watches. A battery can produce enough voltage to weld jewelry to metal causing a severe burn.

Always have plenty of fresh water and soap nearby in case battery acid contacts skin, clothing, or eyes.

OPERATING INSTRUCTIONS

- 1.) Connect the machine to 115V circuit by plugging an extension cord into wall receptacle and the flanged inlet on top of the shroud. Keep the extension cord as short and as large as possible. A small cord will decrease the output of the charger due to the voltage drop in the line. this will increase the charging time.
- 2.) When properly connected, the charge LED will indicate that charge current is flowing to the battery.
- 3.) As the battery becomes charged, the charger is designed to electronically taper off. When the battery comes to its full potential, the green LED will indicating the battery is completely charged and ready for use. Failure of the LED to turn on after sufficient charging time indicates the possibility of one or more dead battery cells. If this condition exists, replace the battery.
- 4.) Remember to unplug the charger before moving equipment. Failure to do so could cause damage to cords, receptacle and other equipment. The motor will not operate while plugged into a 115V circuit.

ADDITIONAL INFORMATION

The On-Board charger is current limited and will not exceed its rated output, even if loads are placed on the battery while the battery is charging.

TROUBLESHOOTING

- 1.) Make sure battery connections are electrically and mechanically sound and batteries are fully charged.
- 2.) Check circuit breaker. Reset if necessary.
- 3.) Check battery condition. A highly sulfated battery may take some time before current begins to flow through it.

DO'S AND DON'TS

- DO NOT** leave charger connected for an indefinite length of time, unless, its supplied by T&S.
- DO NOT** smoke, strike a match or cause a spark in the vicinity of battery during charging.
- DO** make sure all battery connections are tight and clean.
- DO NOT** expose to rain or adverse conditions.
- DO** replace defective cords and wires immediately.