

Ergonomic Solutions

OWNER'S MANUAL

**STEEL GANTRY CRANES • MODEL BAHS
 ALUMINUM GANTRY CRANES • MODEL BAHA**

Contents	
Safety Precautions	1
Receiving Instructions	1
Warranty	1
Assembly Instructions	2
Height Adjustment	3
Inspection Instructions	4
Testing Instructions	5
Parts List/Drawing (FHS series)	6
Parts List/Drawing (FHA series)	7
Warning Label Identification	8

SAFETY PRECAUTIONS

Read owner's manual completely before operating unit!

- Never exceed the maximum capacity printed on top beam.
 ! This capacity includes the weight of hoist and trolley too.
- Check for damage and be sure all hardware is tight before each use.
- Never move or load unless both height adjustment pins are fully inserted.
- Lock all wheels in perpendicular position to one another before loading.
- Stand clear of load while loading and unloading.
- Never cantilever loads off of one end.
- If moving load, be sure load center is as low to ground as possible. If not lowered, tipping can occur.
- Never adjust height when loaded.
- When moving is not required, always lock the casters in perpendicular position to one another.
- Keep clear of electrical wires or any other electrical equipment.
- Make sure all operator safety labels are in place (p.8).

RECEIVING INSTRUCTIONS

Every unit is thoroughly inspected prior to shipment. However, it is possible that the unit may incur damage during transit. If damage is noticed when unloading, make a note of it on the **BILL OF LADING**. Remove all packing and strapping material, then inspect the unit again for damage. **IF DAMAGE IS EVIDENT, FILE A CLAIM WITH THE CARRIER IMMEDIATELY!**

WARRANTY

This product is warranted for 90 DAYS from date of purchase to be free of manufacturing defects in material and workmanship. The manufacturer's obligation hereunder is limited to repairing such products during the warranty period, provided the product is sent prepaid back to the factory.

This warranty does not cover normal wear of parts or damage resulting from any of the following: negligent use or misuse of the product, use or application contrary to installation instructions, or disassembly, repair or alteration by any person prior to authorization from a factory representative.

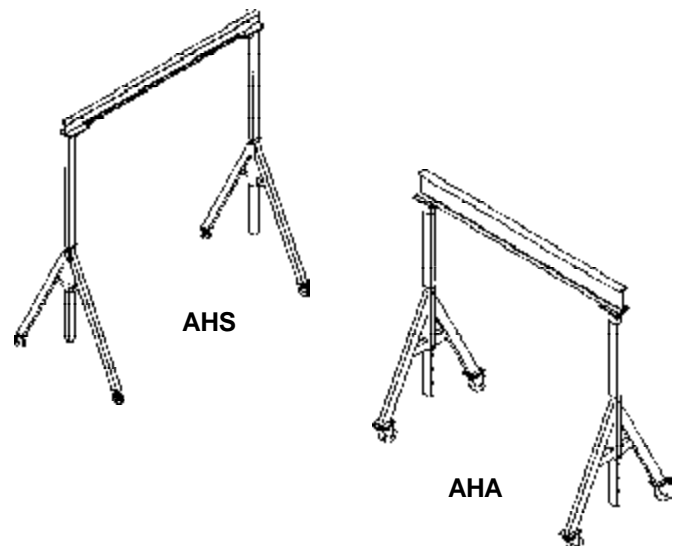

**STEEL & ALUMINUM GANTRY CRANES
 BAHS & BAHA SERIES**

ASSEMBLY INSTRUCTIONS

To assemble the gantry crane, you will need the following:

1. Forktruck or overhead crane
2. Socket or wrench for a 1/2" dia. nut

There are two different ways to assemble the gantry crane using either the help of a forktruck or an overhead crane.

STEP 1 - INSTALLING CRANE TOP BEAM AND LEG ASSEMBLIES

- 1.) Layout the crane top beam and the two leg assemblies on a clear floor area.
- 2.) Attach the beam clamp to the top plate on both leg assemblies using the provided 1/2"-13 structural bolts and nuts.

Note: Torque specs. for bolts is 50 to 52 foot pounds.

For adjustable heights models:

After the beam clamp are attached to the top plate, the side frame (where the top plate is situated) has to be inserted into the leg assemblies, and secured with the height adjustment pins and pin clips.

- 3.) Slide in the top beam between the space of the beam clamp and top plate on both leg assemblies until the desired width is achieved.
- 4.) Tighten all the nuts tightly.
- 5.) Tip the assembly upright into a standing position with the help of a forktruck or overhead crane.
- 6.) Lift the assembly up slowly to a height that is just high enough for the casters to be installed.

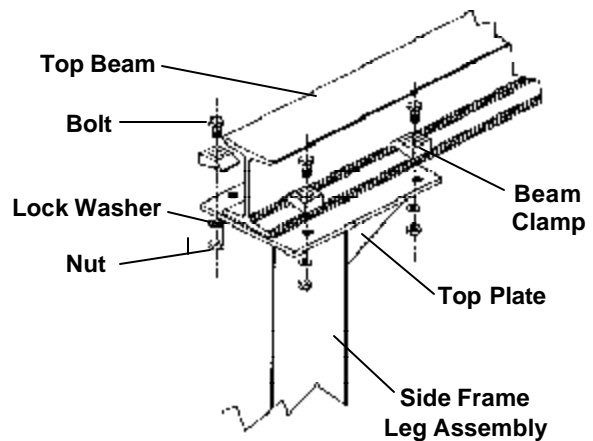

Figure 1

!!! Make sure the fork or the overhead crane is centered at the center of the crane top beam before the assembly is lifted.

STEP 2 - INSTALLING CASTERS (6K and 8K Models)

- 1.) Two 8" dia. (4-way swivel lock) casters are to be installed to each end of the leg assemblies.
- 2.) Insert 1/2"-13 UNC x 1-1/2" long hexhead bolt through the hole in the caster pad to hold the caster in place.
- 3.) Place 1/2"-13 UNC lock nut on each bolt and tighten securely.
- 4.) Lower the assembly slowly.

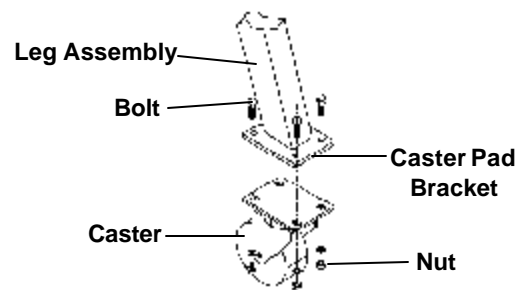

Figure 2

****For all models except the 6,000 lb. and 8,000 lb. units, casters are bolted up to the leg assemblies, holes are threaded so no nuts are needed**

!!! Make sure all the casters are locked in perpendicular position to one another before the assembly is lowered.

HEIGHT ADJUSTMENT

For adjustable height models, the height of the top beam can be adjusted by the following ways:
Never attempt to adjust while loaded.

A.) Using a forklift or an overhead crane

- 1.) Lock all the casters in perpendicular position to one another.
- 2.) A forklift or an overhead crane is used to support the top beam.
- 3.) Release the pin clips from the height adjustment pins on both sides of the frame, and pull out the pins.
- 4.) The top beam can now be lowered or raised to the desired height with the help of the forklift or overhead crane.
- 5.) Insert the height adjustment pins and secure them with the pin clips.

B.) Using the ratchet cable puller (*customer supplied*)

- 1.) Lock all the casters in perpendicular position to one another.
- 2.) Attach one end (hook) of the ratchet cable puller to the bracket (position A) on the leg assembly, and the other end to the end of the side frame (position B). **Please refer to figure below: Figure 3**
- 3.) Tighten the cable to hold the side frame in place.
- 4.) Release the pin clip from the height adjustment pin, and pull out the pin.
- 5.) The top beam can now be lowered or raised to the desired height by extending the cable, or shortening the cable.
- 6.) Insert the height adjustment pin and secure it with the pin clip.
- 7.) Repeat the above procedures for the other side.

CAUTION: NEVER STAND BELOW THE TOP BEAM WHILE TRYING TO ADJUST THE HEIGHT !

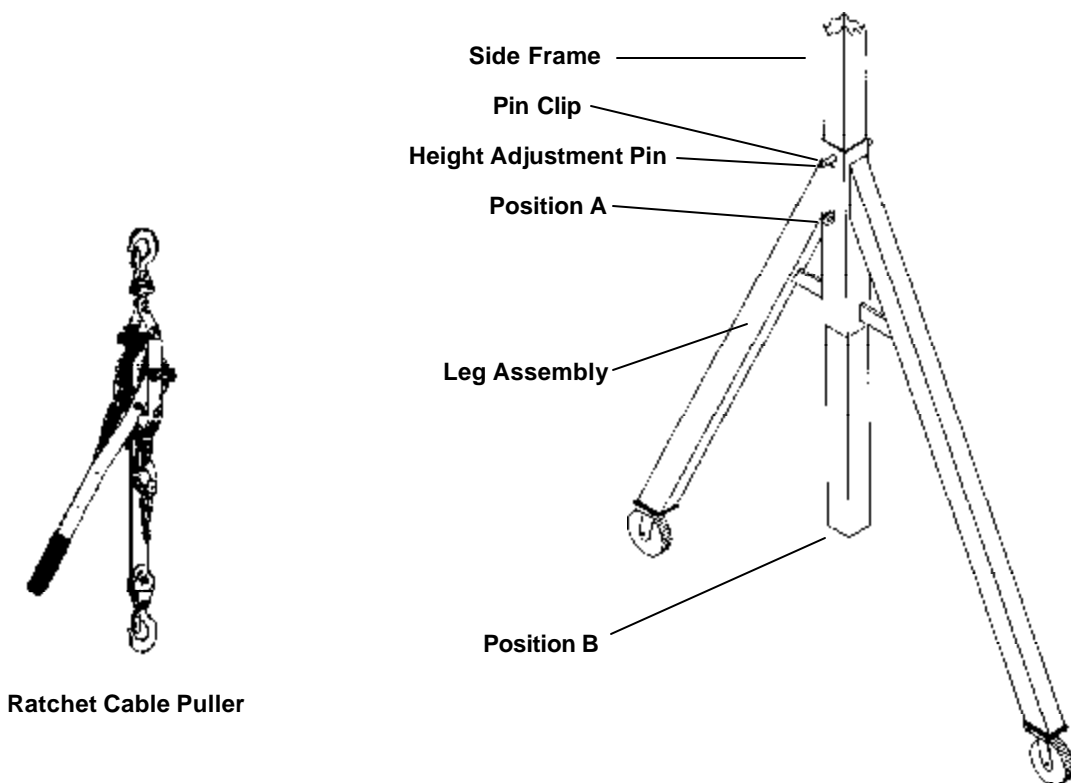

Figure 3

INSPECTION INSTRUCTIONS

Per OSHA Regulations **1910.179** and American Society of Mechanical Engineers (A.S.M.E.) **B30.20 "Overhead Lifting Devices."**, all gantry cranes should have an:

1910.179(j)(1)(i) Initial inspection - Prior to initial use all new and altered cranes shall be inspected to insure compliance.

Besides that, for gantry cranes in regular service, there are two general classifications of inspections based upon the intervals at which the inspection should be performed. The intervals in turn are dependent upon the nature of the critical components of the crane and the degree of their exposure to wear, deterioration, or malfunction. The two general classifications are herein designated as "frequent" and "periodic" with respective intervals between inspections as defined below:

1910.179(j)(1)(ii)(a) Frequent inspection - Daily to monthly intervals.

1910.179(j)(1)(ii)(b) Periodic inspection - 1 to 12 month intervals.

1910.179(j)(2) Frequent Inspection

The following items shall be inspected for defects at intervals as defined above or as specifically indicated, including observation during operation for any defects which might appear between regular inspections. All deficiencies such as listed shall be carefully examined and determination made as to whether they constitute a safety hazard:

- All functional operating mechanisms for maladjustment interfering with proper operation. Daily.
- Hooks with deformation or cracks. Visual inspection daily; monthly inspection with a certification record which includes the date of inspection, the signature of the person who performed the inspection and the serial number, or other identifier, of the hook inspected.
- Hoist chains, including end connections, for excessive wear, twist, distorted links interfering with proper function, or stretch beyond manufacturer's recommendations. Visual inspection daily; monthly inspection with a certification record which includes the date of inspection, the signature of the person who performed the inspection and an identifier of the chain which was inspected.
- All functional operating mechanisms for excessive wear of components.
- Rope reeving for noncompliance with manufacturer's recommendation.

1910.179(j)(3) Periodic Inspection

Complete inspections of the crane shall be performed at intervals as generally defined above, depending upon its activity, severity of service, and environment, or as specifically indicated below. These inspections shall include the requirements of the frequent inspection stated above and in addition, the following items. All deficiencies such as listed shall be carefully examined and determination made as to whether they constitute a safety hazard:

- Deformed, cracked, or corroded members.
- Loose bolts or fasteners.
- Cracked or worn hoist.
- Worn, cracked or distorted parts such as pins, bearings, shafts, gears, rollers, locking and clamping devices.
- Load, wind, and other indicators over their full range, for any significant inaccuracies.
- Gasoline, diesel, electric, or other powerplants for improper performance or noncompliance with applicable safety requirements. (IF APPLICABLE)
- Excessive wear of chain drive sprockets and excessive chain stretch.

TESTING INSTRUCTIONS

OSHA also requires two classifications of testing to be performed [per OSHA Regulations **1910.179(k)**]. These two testings are:

1910.179(k)(1) Operational tests

1910.179(k)(2) Rated load test

1910.179(k)(1) Operational Tests

- (i) Prior to initial use all new and altered cranes shall be tested to insure compliance with this section including the following functions:
 - (a) Hoisting and lowering.
 - (b) Trolley travel.
 - (c) Bridge travel.
 - (d) Limit switches, locking and safety devices.
- (ii) The trip setting of hoist limit switches shall be determined by tests with an empty hook traveling in increasing speeds up to the maximum speed. The actuating mechanism of the limit switch shall be located so that it will trip the switch, under all conditions, in sufficient time to prevent contact of the hook or hook block with any part of the trolley.

1910.179(k)(2) Rated Load Test

Test loads shall not be more than 125 percent of the rated load unless otherwise recommended by the manufacturer. The test reports shall be placed on file where readily available to appointed personnel.

**REFER TO OSHA'S STANDARD 1910.179 FOR COMPLETE INFORMATION ON
OVERHEAD & GANTRY CRANE DEFINITIONS, GENERAL REQUIREMENTS,
HOISTING EQUIPMENT, MAINTENANCE, ROPE INSPECTION,
HANDLING OF THE LOAD, AND
OTHER REQUIREMENTS.**

For OSHA publications, including informational materials
on standards and regulations, please contact:

OSHA's Publications Office
200 Constitution Avenue, N.W., Room N3101
Washington, DC 20210
Ph.: (202)219-4667 Fax: (202)219-9266

**ALSO REFER TO AMERICAN SOCIETY OF MECHANICAL ENGINEERS (A.S.M.E.)
B30.20 "OVERHEAD LIFTING DEVICES."**

For copies of A.S.M.E. B30.20
please contact:

American Society of Mechanical Engineers
Order Department 1-800-THE-ASME

BAHS SERIES STEEL GANTRY CRANES

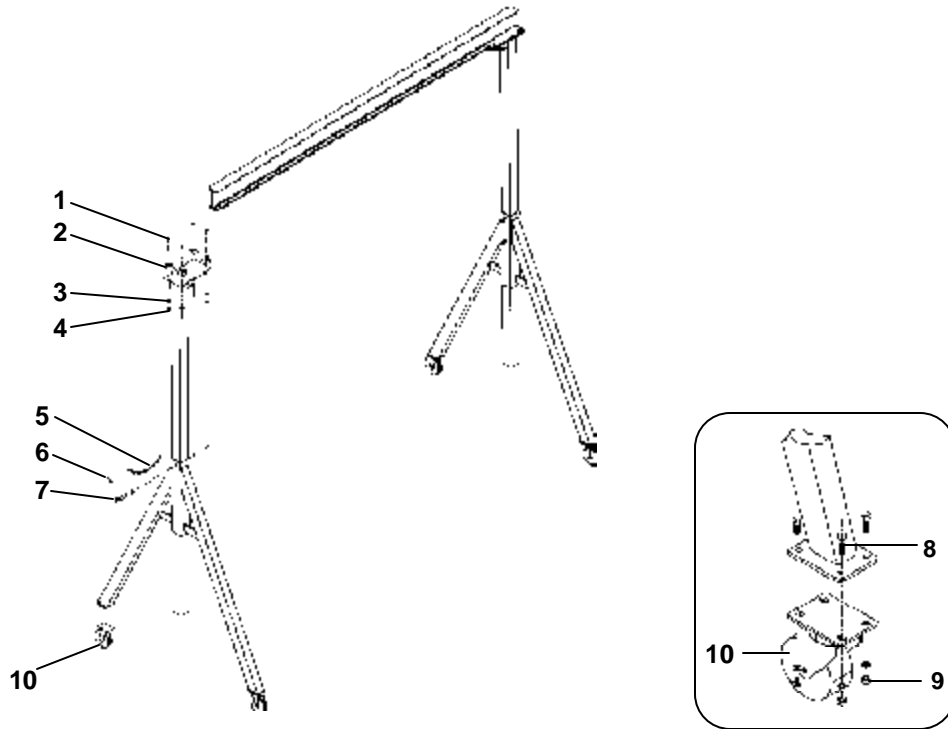

PARTS IDENTIFICATION BAHS SERIES STEEL GANTRY CRANES

KIT NO.	ITEM NO.	DESCRIPTION	ENGINEER NO.	PART NO.	QTY.
A	1	Bolt, 1/2"-13 x 2" (HHCS)	B11211	BAHS-BLT1	8
	2	Beam Clamp	B28-145-002	BAHS-IBCMPL	8
A	3	Lock washer, 1/2"	B33625	BAHS-LW	8
A	4	Nut, 1/2"-13	B36109	BAHS-NUT1	8
	5	Chain, 3/16" dia. x 16"	B08-145-011	BAHS-CN	2
A	6	Hitch pin clip, # 8	B45284	BAHS-HPC	2
	7	Pin, 1" dia. x 5-3/4" overall (4.5" usable)	B08-112-002	BAHS-PIN	2
A,B	8	Bolt 3/8"-16 UNC x 5" lg.	B21373	BAHS-BLT2	16
A,B	9	Nut 3/8" x 16	B37024	BAHS-NUT2	16
B,C	10	Wheel, caster	B16-134-063	BAHS-WC	4
		Wheel, caster [6000 lbs capacity models only]	B16-132-064	BAHS-WC6	4
A,C	11	Bolt, 3/8"-16 x 1" [6000 lbs capacity models only]	B11105	BAHS-BLT3	16
A,C	12	Nut, 3/8"-16 [6000 lbs capacity models only]	B36106	BAHS-NUT3	16
A,C	13	Washer, 3/8" [6000 lbs capacity models only]	B33008	BAHS-WSR	16
	A	Hardware Kit (includes 1,3,4,6,8,9,11,12)	B28-154-001	BAHS-HK	1
	B	Wheel Kit (includes 8,9,10)	B28-154-002	BAHS-WK	1
	C	Wheel Kit 6,000 lb. Units (includes 10,11,12)	B28-154-003	BAHS-WK6	1

a/k Available only with purchase of kit

Note: Item # 11, # 12 and #13 are not shown. Used to attach the casters to the leg assemblies

BAHA SERIES ALUMINUM GANTRY CRANES

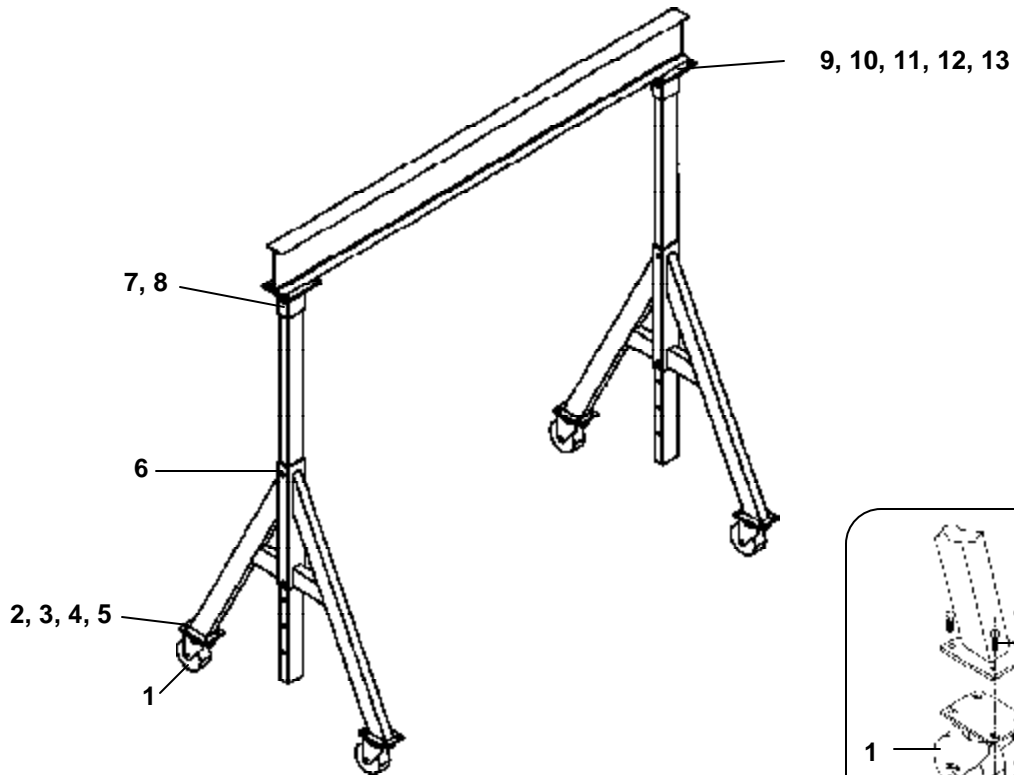

PARTS IDENTIFICATION BAHA SERIES ALUMINUM GANTRY CRANES

KIT NO.	ITEM NO.	DESCRIPTION	ENGINEER NO.	PART NO.	QTY.
A	1	Caster, 8 x 2 Phenolic	B16-132-034	BAHA-8X2PC	4
A,C	2	Bolt 1/2 - 13 unc x 1-1/2 lg.	a/k	a/k	16
A,C	3	Nut, 1/2 -13 unc Hex Head Nut	a/k	a/k	16
A,C	4	Washer, 1/2" Flat Washer	a/k	a/k	16
A,C	5	Lock Washer 1/2"	a/k	a/k	16
B	6	Retaining Pin & Clip	B28-145-001	BAHA-RPC	2
B	7	Retaining Pin, 1/2 x 5 lg.	B28-112-005	BAHA-RP1/2	2
B	8	Pin, 1/8" Cotter Pin	a/k	a/k	2
	9	Beam Clamp	B28-145-002	BAHA-IBCMP	8
C	10	Bolt 1/2" - 13 unc x 2-1/2 lg. Grade 5	a/k	a/k	8
C	11	Nut 1/2-13 unc Hex Head Nut Grade 5	a/k	a/k	8
C	12	Washer 1/2 Flat Washer	a/k	a/k	16
	13	Lock Washer, 1/2"	a/k	a/k	8
A		Caster Kit	B28-154-006	BAHA-KITA	16
B		Pin Kit	B28-154-007	BAHA-KITB	1
C		Hardware Kit	B28-154-008	BAHA-KITC	1

a/k Available only with purchase of kit

WARNING LABEL IDENTIFICATION

MAKE SURE ALL WARNING LABELS ARE IN PLACE!

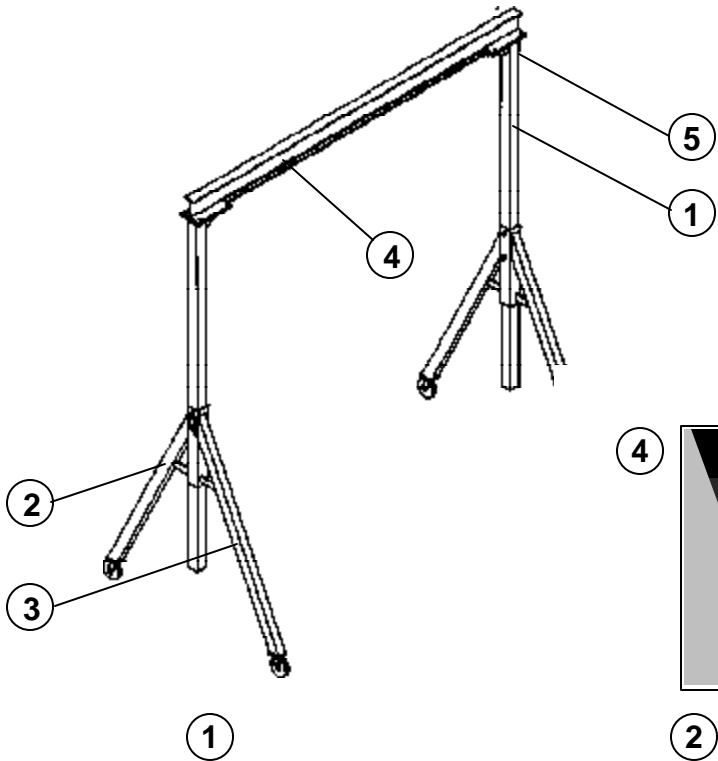

5

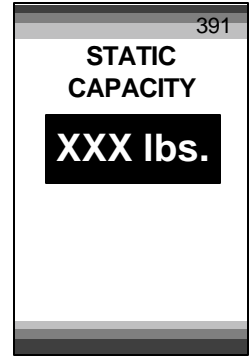

*Product safety signs or labels should be periodically inspected and cleaned by the product users as necessary to maintain good legibility for safe viewing distance .

ANSI 535.4 (10.21)
Contact manufacturer for replacement labels if needed.

4

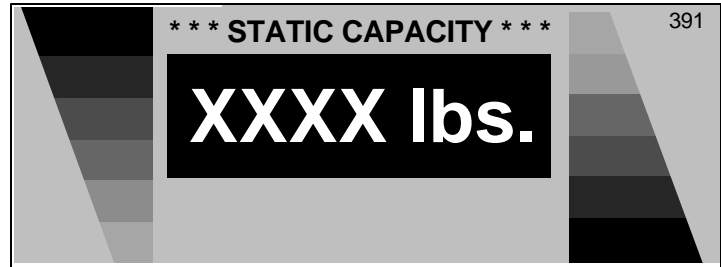

1

⚠ WARNING
CRANE INSPECTION
This lifter was built in accordance with our interpretations of A.S.M.E. B30.20 "Overhead Lifting Devices" and 49 CFR 1910.179 "Overhead & Gantry Cranes."
Prior to initial use, all new, modified or repaired lifters need to be load tested not more than 125% of the rated load. At least once per year, OSHA requires a complete inspection of this Gantry Crane. Refer to 49 CFR 1910.179 (J)(3). Visual inspection should be conducted periodically depending upon frequency of usage. If this lifter shows any deficiencies, corrections shall be made of the unit immediately or it shall be taken out of use.
Thoroughly read A.S.M.E. Code B30.20 "Overhead Lifting Devices" and 49 CFR 1910.179 "Overhead & Gantry Cranes" for complete information.
Copies of A.S.M.E. B30.20 can be obtained from American Society of Mechanical Engineers Order Department 1-800-THE-ASME
Copies of 49 CFR 1910.179 can be obtained from OSHA's Publications Office (202)219-4667

⚠ AVISO
INSPECCIÓN DE LA GRÚA
Este elevador ha sido construido en acuerdo con nuestra interpretación del A.S.M.E. B30.20 "Aparatos de elevación" y 49 CFR 1910.179 "Elevación de gruas."
Antes del uso inicial, todos los elevadores nuevos, modificados o reparados deben de ser probados con una carga que no exceda el 125% de la capacidad de carga. Como mínimo una vez al año, OSHA requiere una inspección completa de esta grúa. Referirse a 49 CFR 1910.179 (J)(3). Una inspección visual se debe de hacer periódicamente dependiendo de la frecuencia de uso. Si este elevador tiene alguna deficiencia, se debe de corregir inmediatamente o se debe de retirar del uso.
Lea completamente el Código A.S.M.E. Code B30.20 "Aparatos de elevación" y 49 CFR 1910.179 "Elevación y gruas" Para la información completa.
Copias de A.S.M.E. B30.20 Se pueden obtener en American Society of Mechanical Engineers Order Department 1-800-THE-ASME.
Copias de 49 CFR 1910.179 se pueden obtener en la oficina de publicaciones de OSHA (202)219-4667.

⚠ AVERTISSEMENT
INSPECTION DE GRUE
Cet élévateur a été construit en accord avec les interprétations d' A.S.M.E. B30.20. "Matériaux de sur-élévation" ainsi qu'avec les interprétations 49 CFR 1910.179 "Sur-élévation et grues portiques."
Avant l'utilisation initiale, tout élévateur nouveau, modifié, ou réparé doit être testé avec un chargement ne pouvant pas excéder 125% du taux de chargement dont il est capable. Au moins une fois par an, OSHA demande qu'une complète inspection de cette grue portique soit effectuée. Se rapporter à l'article 49 CFR 1910.179 (J) (3). Une inspection visuelle devrait être effectuée périodiquement selon la fréquence d'utilisation de l'unité. Si cet élévateur montre une quelconque déficience, des corrections devraient immédiatement être apportées ou celui-ci devrait être retiré du service.
Lire avec attention le code A.S.M.E. B30.20 concernant les "Matériaux de sur-élévation" ainsi que les code 49 CFR 1910.179 "Sur-élévation et grues portiques" pour toute information complète.
Des copies du code ASME B30.20 peuvent être obtenues au département de commande de l' "American Society of Mechanical Engineers". Au numéro 1-800-THE-ASME.
Des copies du code 49 CFR 1910.179 peuvent être obtenues au bureau des publications OSHA au numéro (202)219-4667.

2

⚠ DANGER
This unit conducts electricity
KEEP CLEAR OF POWER LINES!
Do not let unit make contact with wires or any other electrical equipment.
NEVER stand under load
NEVER push unit or adjust height when loaded.

⚠ PELIGRO
Esta unidad es conductora de electricidad
MANTENGA ALEJADO DE ALAMBRES ELÉCTRICOS!
No deje que la unidad haga contacto con alambres eléctricos u otro equipo eléctrico.
NUNCA se ponga de pie bajo la unidad.
NUNCA empuje la unidad cargada o ajuste la altura.

⚠ DANGER
Cette unité conduit de l'électricité
RESTER À L'ÉCART DES LIGNES ÉLECTRIQUES!
Ne pas mettre l'unité en contact avec des fils électriques ou tout autre équipement électrique.
NE JAMAIS se tenir sous le chargement.
NE JAMAIS pousser l'unité ou ajuster la hauteur lorsque l'unité est chargée.

3

⚠ DANGER
Use with Caution
• Lock All Wheels In Perpendicular Position To One Another Before Loading
• Check For Damage And Be Sure All Hardware Is Tight Before Each Use. Remove From Service And Repair Immediately If Necessary
• Never Exceed Capacity Printed On I-Beam
• Never Move Or Load Unless Both Height Adjustment Pins Are Fully Inserted
• Never Cantilever Loads Off Of One End
• Always Include Weight Of Hoist And Trolley When Calculating Load
• Use On Level Concrete Or Equal Surface

⚠ PELIGRO
Use con Precaución
• Asegure Todas Las Ruedas En La Posición Perpendicular Antes De Cargar La Unidad.
• Compruebe por daños y asegúrese que toda La Ferretería Está Sujeta Antes De Cada Uso. Retire Del Servicio Y Repare Inmediatamente Si Es Necesario.
• Nunca Exceda La Capacidad Impresa En La Viga I
• Nunca Mueva O Cargue La Unidad A No Ser Que Ambos Pasadores De Ajuste De Altura Esten Completamente Insertos.
• Nunca Deje Que La Carga Sobresalga En Un Solo Extremo.
• Siempre Incluya El Peso De La Grúa Y La Carretilla Cuando Se Calcule La Carga.
• Use En Cemento A Nivel O En Una Superficie Equivalente.

⚠ AVERTISSEMENT
Utiliser Avec Prudence
• Bloquer Chaque Roue En Position Perpendiculaire À Une Autre Avant De Charger.
• Contrôler Tout Dommage Et S'assurer Que Tout Le Matériel Soit Bien Serré Avant Chaque Utilisation. Retirer Du Service Et Réparer Immédiatement Si Nécessaire.
• Ne Jamais Excéder La Capacité Imprimée Sur La Poutre.
• Ne Jamais Déplacer Ou Charger Sans Que Les Deux Goupilles D'Ajustement De Hauteur Ne Soient Complètement Insérées.
• Ne Jamais Cantilever Les Charges D'une Des Extrémités,
• Toujours Inclure Le Poids De Levage Et De Chariage Pour Calculer La Charge.
• Utiliser Sur Un Ciment À Niveau Ou Sur Une Surface Équivalente.

255

256