

**Drum Handling Solutions**

# OWNER'S MANUAL

## DRUM CARRIER / ROTATOR SERIES BDCR-205

**Contents**

Warnings and Safety Instructions .....	1 & 2	Warning Label Identification .....	2
Receiving Instructions .....	1	Periodic Maintenance Instructions .....	2
Warranty .....	1	Parts List .....	3
Operating Instructions .....	2	Location of Center of Gravity .....	4

**WARNINGS & SAFETY INSTRUCTIONS**

*Read owner's manual completely before operating unit!*

- Never operate drum carrier/rotator unless you are watching it.
- Never use the drum carrier/rotator if the cradle is in need of repairs or in the case of a malfunction.
- Do not stand below any part of a raised drum carrier/rotator or drum.
- Never exceed the maximum loading capacity of the drum carrier/rotator as described below:  
 Model BDCR-205-8: 800 pounds for FULL drum, or 500 pounds for HALF-FULL drum.  
 Model BDCR-205-15: 1500 pounds for FULL drum, or 900 pounds for HALF-FULL drum.
- Always load drum at the center of the cradle.
- Consult factory for uneven loading.
- When elevation is not required, always transport the drum in the lowered position.
- Always transport drum only in vertical position when fork truck is moving.
- Do not allow drum to impact on floor, ground, or dumping station etc., or there may be damage to the unit.
- Remove drum before working on unit.
- Consult factory if adding or performing any modification to the original equipment.
- Use only maintenance parts supplied or approved by the manufacturer.
- Make sure all operator safety labels are in place (p.2).

**RECEIVING INSTRUCTIONS**

Every unit is thoroughly tested and inspected prior to shipment. However, it is possible that the unit may incur damage during transit. If damage is noticed when unloading, make a note of it on the **BILL OF LADING**. Remove all packing and strapping material, then inspect the unit again for damage. **IF DAMAGE IS EVIDENT, FILE A CLAIM WITH THE CARRIER IMMEDIATELY!**

**WARRANTY**

This product is warranted for 90 DAYS from date of purchase to be free of manufacturing defects in material and workmanship.

This warranty does not cover normal wear of parts or damage resulting from any of the following: negligent use or misuse of the product, use or application contrary to installation instructions, or disassembly, repair or alteration by any person prior to authorization from a factory representative.

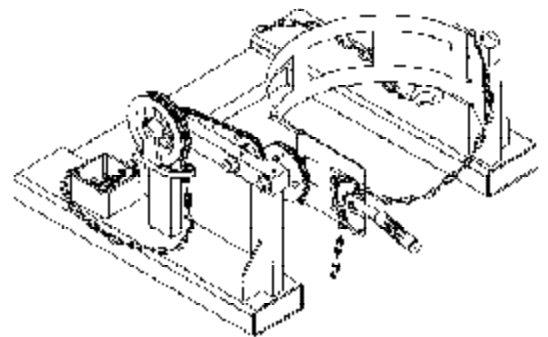

**DRUM CARRIER / ROTATOR  
BDCR-205 SERIES**

## Safety Instructions For The Operator

- 1.) Please read all instructions THOROUGHLY before attempting to operate your new Drum Carrier/Rotator.
- 2.) The Model BDCR-205-8 has a MAXIMUM CAPACITY RATING of 800 pounds for FULL drum, and 500 pounds for HALF-FULL drum. The Model BDCR-205-15 has a MAXIMUM CAPACITY RATING of 1500 pounds for FULL drum, and 900 pounds for HALF-FULL drum. Both models are intended for lifting, moving, and pouring drums of size and type noted above. DO NOT exceed these ratings as the unsafe condition that may result could cause damage or excessive wear, or make the unit awkward to handle.
- 3.) When operating, loading, unloading, or maintaining your drum carrier/rotator, always use care and good judgement, have good footing and a firm hold. Keep hands and loose clothing etc., away from all moving parts. Never allow anyone to be below any part of a raised Drum Carrier/Rotator or drum. Read operating instructions before operation.

## Operating Instructions

- 1.) Adjust the forks so that the inside width between the forks is 24 1/2" minimum. One fork must be locked to bed plate.
- 2.) Drive the truck forward to slip forks into fork sleeves. Attach safety chain to mast to secure drum carrier/ rotator to forks.
- 3.) Open carrier cradle full width and hook cradle chain on stud.
- 4.) Drive truck with forks near floor level to position carrier cradle around drum. Lock drum in place by clinching chain with ratchet tightener.
- 5.) Remove control chain from box and place end of loop near operator's seat.
- 6.) Raise forks and transport drum in VERTICAL position.
- 7.) TO POUR DRUM: Pull on chain, rotating drum to angle required for emptying. For best control of drum pouring angle, pay out one side of the loop while pulling in the other.
- 8.) After emptying, rotate drum back to vertical position and drive the truck to deliver drum.

## Periodic Maintenance Instructions

- 1.) Lubricate gear-train once a month with a good grade lube. There are three grease fittings on the gear block for Model DCR-205-8 and four grease fittings for Model DCR-205-15 and one grease fitting in the idler bearing block.
- 2.) Oil cradle hinges, ratchet, pawl, chain and other moving parts periodically.
- 3.) Periodically inspect all moving parts, framework, and contact areas for signs of wear, fatigue or loosening. Tighten, adjust or replace parts as necessary to prevent failure and maintain proper functions.

## WARNING LABEL IDENTIFICATION

MAKE SURE ALL WARNING LABELS ARE IN PLACE!

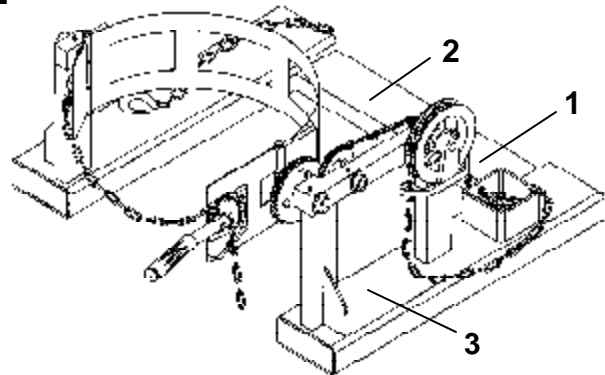

**1**

**CAUTION** 294

DRUM MUST BE IN A VERTICAL POSITION WHEN MOVING  
 MODEL: DCR-205-15  
 CAPACITY: 1,500 LBS.

T & S EQUIPMENT CO. ANGOLA, IN  
 Ph. (219)665-9521 Fax (219)665-1339

**CAUTION** 293

DRUM MUST BE IN A VERTICAL POSITION WHEN MOVING  
 MODEL: DCR-205-8  
 CAPACITY: 800 LBS.

T & S EQUIPMENT CO. ANGOLA, IN  
 Ph. (219)665-9521 Fax (219)665-1339

**2**

<b>CAUTION</b>	<b>PRECAUCION</b>	<b>PRUDENCE</b>
SAFETY CHAIN MUST BE FASTENED SECURELY TO FORKLIFT	LA CADENA DE SEGURIDAD DEBE DE SER AGARRADA CON SEGURIDAD A LA TRANSPALETA	LA CHAÎNE DE SÉCURITÉ DOIT ÊTRE BIEN ATTACHÉE AU MONTE-CHARGE <small>218</small>

\*Product safety signs or labels should be periodically inspected and cleaned by the product users as necessary to maintain good legibility for safe viewing distance ... ANSI 535.4 (10.21)  
 Contact manufacturer for replacement labels.

**3**

<b>CAUTION</b>	<b>PRECAUCION</b>	<b>PRUDENCE</b>
DRUM MUST BE IN VERTICAL POSITION WHEN MOVING	EL TAMBOR DEBE DE ESTAR EN LA POSICIÓN VERTICAL CUANDO EN MOVIMIENTO	LE BIDON DOIT ÊTRE EN POSITION VERTICALE LORS D'UN DÉPLACEMENT <small>232</small>

DRUM CARRIER / ROTATOR • BDCR-205-8 & BDCR-205-15 (Type T)

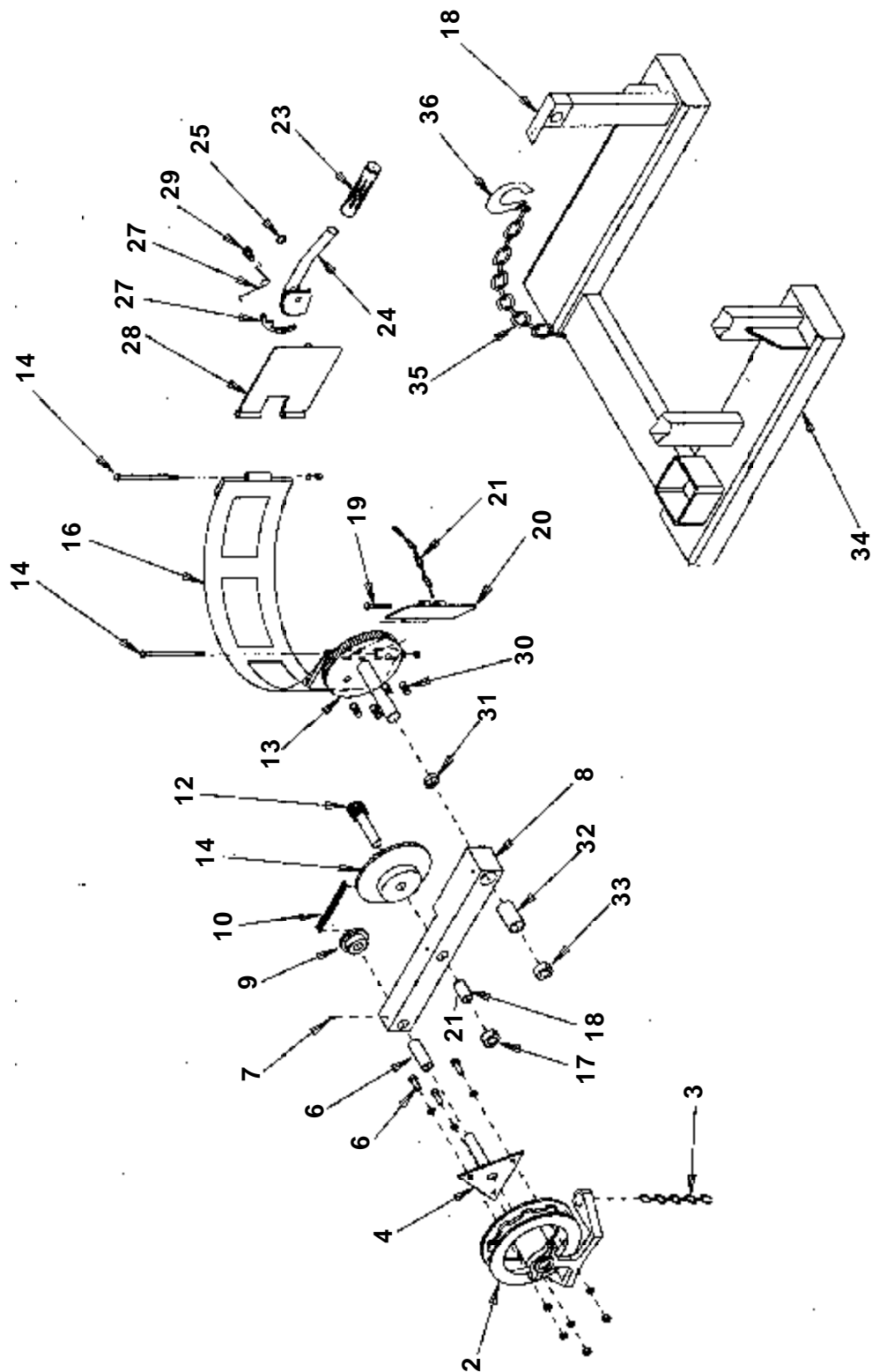

## DRUM CARRIER / ROTATOR • BDCR-205-8 & BDCR-205-15 (Type T)

ITEM NO.	DESCRIPTION	ENGINEER NO.
1	Hand Wheel (not shown)	B1A-P
2	Chain Wheel	B1-P
3	Bobbit Lock Link Chain 20 ft.	B2-P
4	Chain Wheel Shaft with Triangle End Bolts	B3-P
5	Bolt & Nut 5/16-18 x 1	B35-P
6	Bearing 3/4 ID x 2-1/2	B19-P
7	Grease Fitting Alemite	B33-P
8	Washer 3/4	B55-P
9	Sprocket (12T #35)	B11-P
10	Roller Chain (#35 - 3/8 pitch)	B12-P
11	Sprocket 36T #35	B13-P
12	Pinion Gear (7T x 1" ID)	B14-P
13	Spur Gear (72T x 1" ID)	B23-P
14	Hinge Pin & Nuts	B157-P
15	Cradle Assy. for 55 Gallon Drum	B1048-P
16	Bearing (Randall SH 186)	B7-P
17	Collar (3/4" ID)	B15-P
18	Bearing Block	B53-P
19	Chain Bolt & But (3/8-16 x 2-1/2)	B155-P
20	Chain Hinge Plate	B150-P
21	Binder Chain	B180-P
23	Handle Grip	B136-P
24	Ratchet	B165-P
25	Snap Ring	B166-P
26	Pawl	B168-P
27	Pawl Spring	B169-P
28	Pawl & Ratchet Hinge Plate	B159-P
29	Pawl Shoulder Screws & Nut	B170-P
30	Spur Gear Screws (3/8-24)	B22-P
31	Spur Gear Spacer	B29-P
32	Bearing 1" ID x 2-1/2	B18-P
33	Collar (1" ID)	B16-P
34	Base Frame	BDCR-205-FB
35	Safety Chain	BDCR-205-SC
36	Safety Hook	BDCR-205-SH

DRUM CARRIER / ROTATOR • BDCR-205-8 & BDCR-205-15 (Type C)

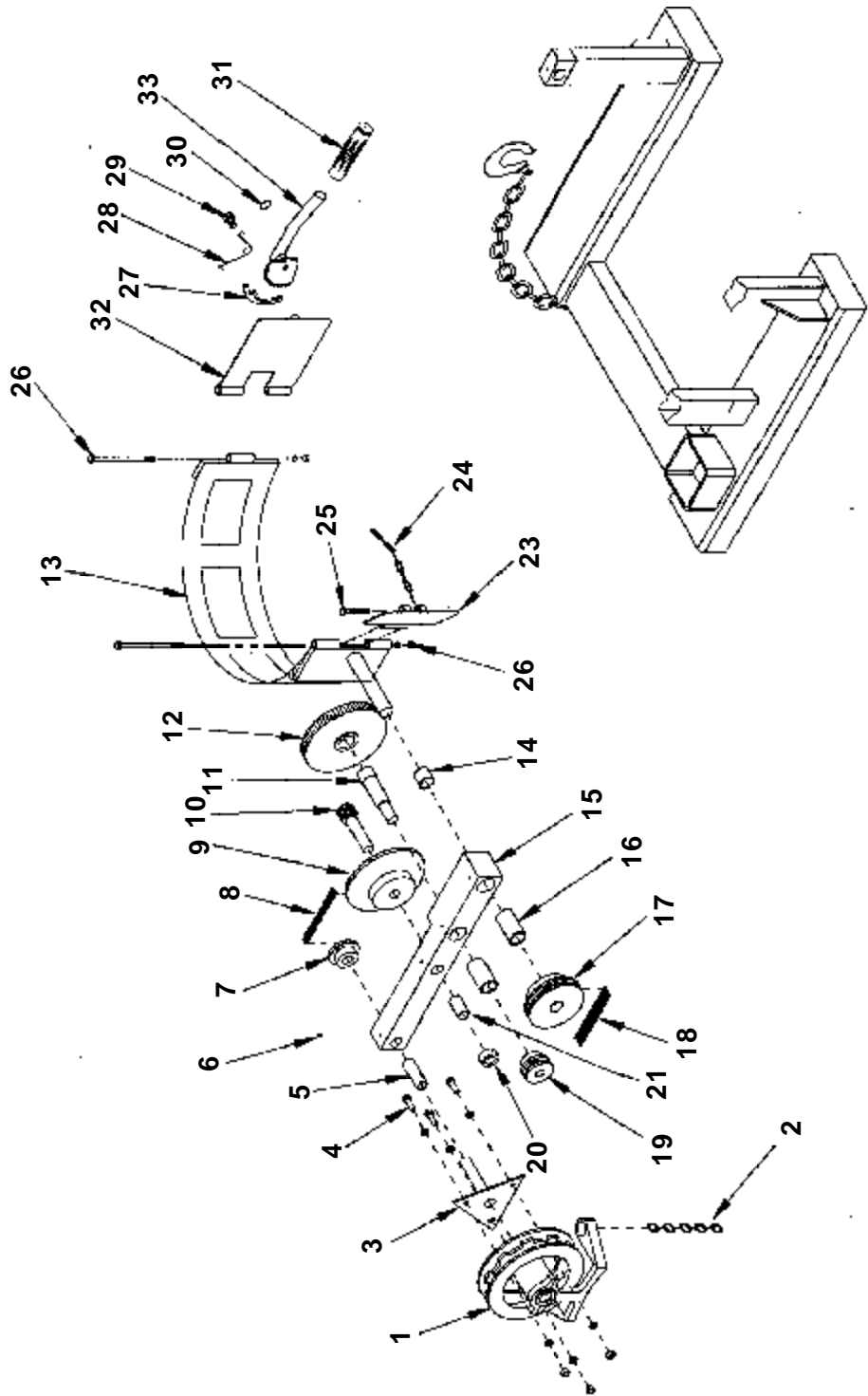

## DRUM CARRIER / ROTATOR • BDCR-205-8 & BDCR-205-15 (Type T)

ITEM NO.	DESCRIPTION	ENGINEER NO.
1	Chain Wheel	B09-042-011
2	#1/0 Bobbit Lock Link Chain 20 ft.	B09-145-007
3	Chain Wheel Shaft with Triangle	B09-516-059
4	Bolt & Nut 5/16 - 18 x 1	B35-P
5	Bearing 3/4 ID x 2-1/2 Lg.	B01-111-048
6	Grease Fitting Alemite	B33-P
7	Sprocket (12T #35)	B09-042-004
8	Roller Chain (#35 - 3/8 pitch)	B09-042-006
9	Sprocket (36T)	B09-042-003
10	Pinion Gear (11 Tooth with Key)	B09-042-007
11	Shaft, 4-5/8" Long	B09-112-013
12	Spur Gear (72 T x 1-1/8" Lg.)	B09-042-008
13	Cradle Assembly	B09-538-002
14	Spacer, 1.03 ID x 1-1/8" Lg.)	B09-113-003
15	Base Frame	B09-514-066
16	Bearing 1" ID x 2-1/4"	B01-111-047
17	Double Sprocket 24T	B09-042-001
18	Double Sprocket chain	B09-042-005
19	Double Sprocket 12T	B09-042-002
20	Bearing	B01-111-048
21	Collar	B09-145-001
23	Chain Hinge Plate	B09-516-007
24	Binder Chain	B09-145-008
25	Chain Bolt & Nut (3/8 - 16 x 2-1/2)	B155-P
26	Hinge Pin & Nuts	B157-P
27	Pawl	B09-042-012
28	Pawl Spring	B09-146-001
29	Pawl Shoulder Screws & Nut	B170-P
30	Snap Ring	B166-P
31	Handle Grip	B09-025-016
32	Ratchet Plate	B09-516-012
33	Ratchet Lever	B09-042-014

n/a Not Available

# LOCATION OF CENTER OF GRAVITY

## MODEL BDCR-205-8

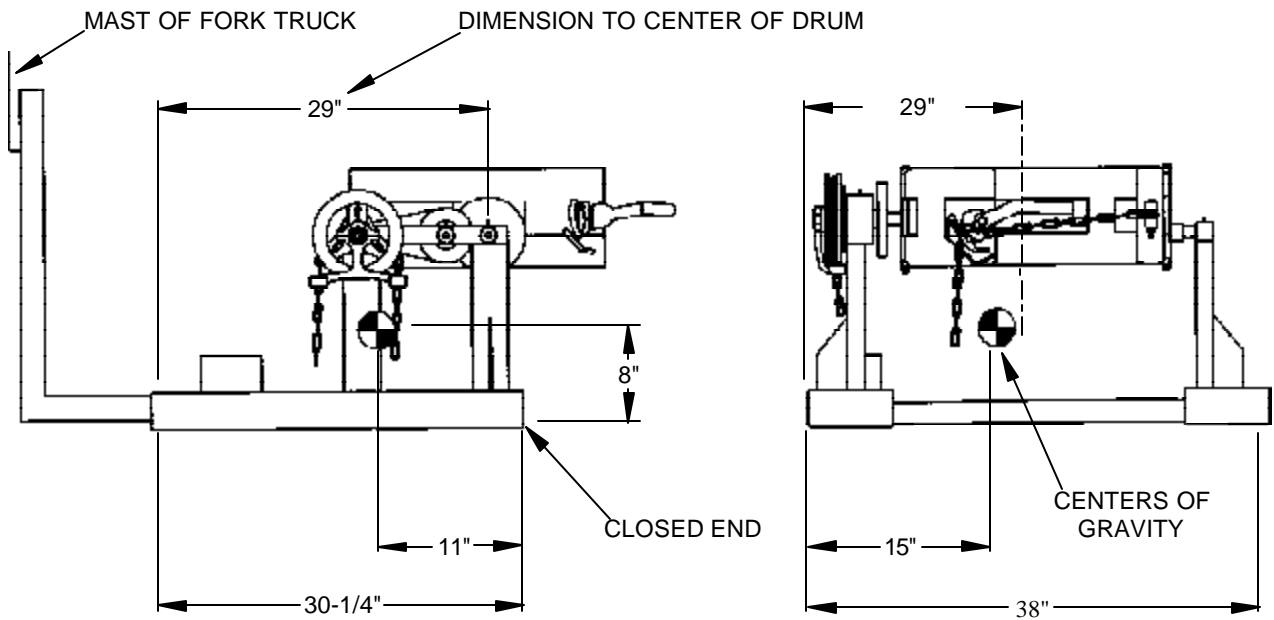

CAPACITY: 800 LBS.  
TOTAL 160 LBS. LOST LOAD  
FORK TUBES: 7-1/4" WIDE BY 2-1/4" HIGH

## MODEL BDCR-205-15

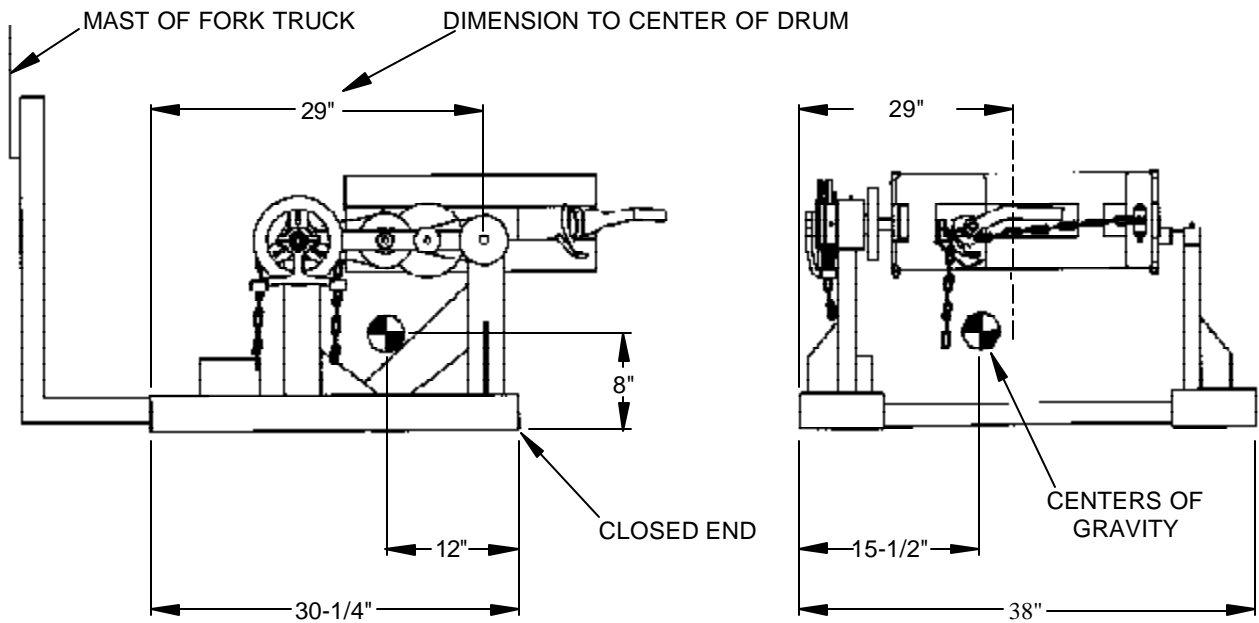

CAPACITY: 1500 LBS.  
TOTAL 225 LBS. LOST LOAD  
FORK TUBES: 7-1/4" WIDE BY 2-1/4" HIGH

# Material Handling Problem Solvers

Scissor Lift Table

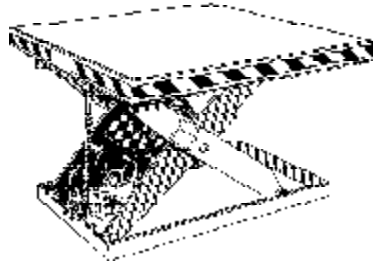

Pallet Server

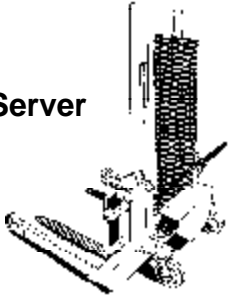

High Rise Lift

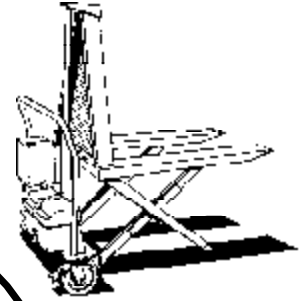

Time is money.  
Increased productivity  
equals greater profitability,  
cost minimization and worker  
compatibility. Ergonomic  
products will assist you  
with your production and  
safety goals.

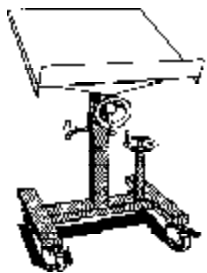

Mobile Lift &  
Tilt  
Work Stand

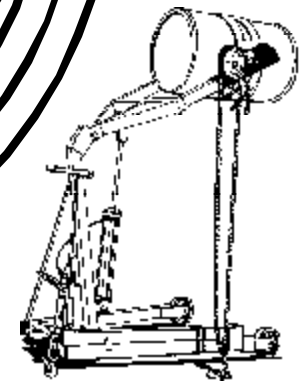

Drum Carrier/Rotator

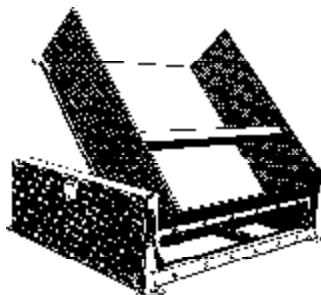

Ground Lift Tilter