

# BMVR Series

## Mechanical Truck Restraints

**BEACON** 

**Beacon Industries, Inc.**  
12300 Old Tesson Rd.  
St. Louis, MO 63128-2247 USA  
Phone: (314) 487-7600 Fax: (314) 487-0100  
[www.beacontechology.com](http://www.beacontechology.com)  
E-Mail: [sales@beacontechology.com](mailto:sales@beacontechology.com)

The **BMVR** is designed for grade mounting at dock face. Proper performance relies on adequate preparation and installation. Read the manual to fully familiarize yourself with the added value of this safety equipment. When properly installed and operated the BMVR will provide many years of optimal service.

Be sure adequate electrical service is offered (BMVR-103 and BMVR-105) to insure proper operation of all electrical circuits.

If any information provided herein is not fully understood, contact your local BEACON representative or BEACON direct.

# “IMPORTANT”

Visually inspect the unit each time it is used.

Make special note of proper caution light operation and correct hook movement.

Standard Lock Out / Tag Out procedures must be enforced in case of any of the following:

- *LED light failure*
- *Hook doesn't move because of debris or damage.*
- *Any type of electrical or mechanical malfunction.*

## **WARNING:**

Premature trailer departure could result in severe injury of even death. Always visually inspect the unit to make sure it is secured to the ICC bar.

# ARRANGEMENT OF THE DOCK AREA

This unit is designed for grade level location. If local conditions warrant, the Restraint Console may be located above grade. BEACON recommends limiting above grade mounting to less than 2" to maintain clearance for projected new standards allowing lower ICC frame sections.

The success and strength of any installed product relies heavily on the conditions of the material surrounding the installation site. This will include the dock face and adjoining drive area for the BMVR-100 (BMVR-103 & BMVR-105) Vehicle Restraint. Repair any structural defects to the dock face and/or drive prior to attempting equipment installation. If necessary, prepare alternate attachment methods to accommodate on-site conditions or contact your local representative or BEACON to assist in preparation of accessories needed to adequately secure this product.

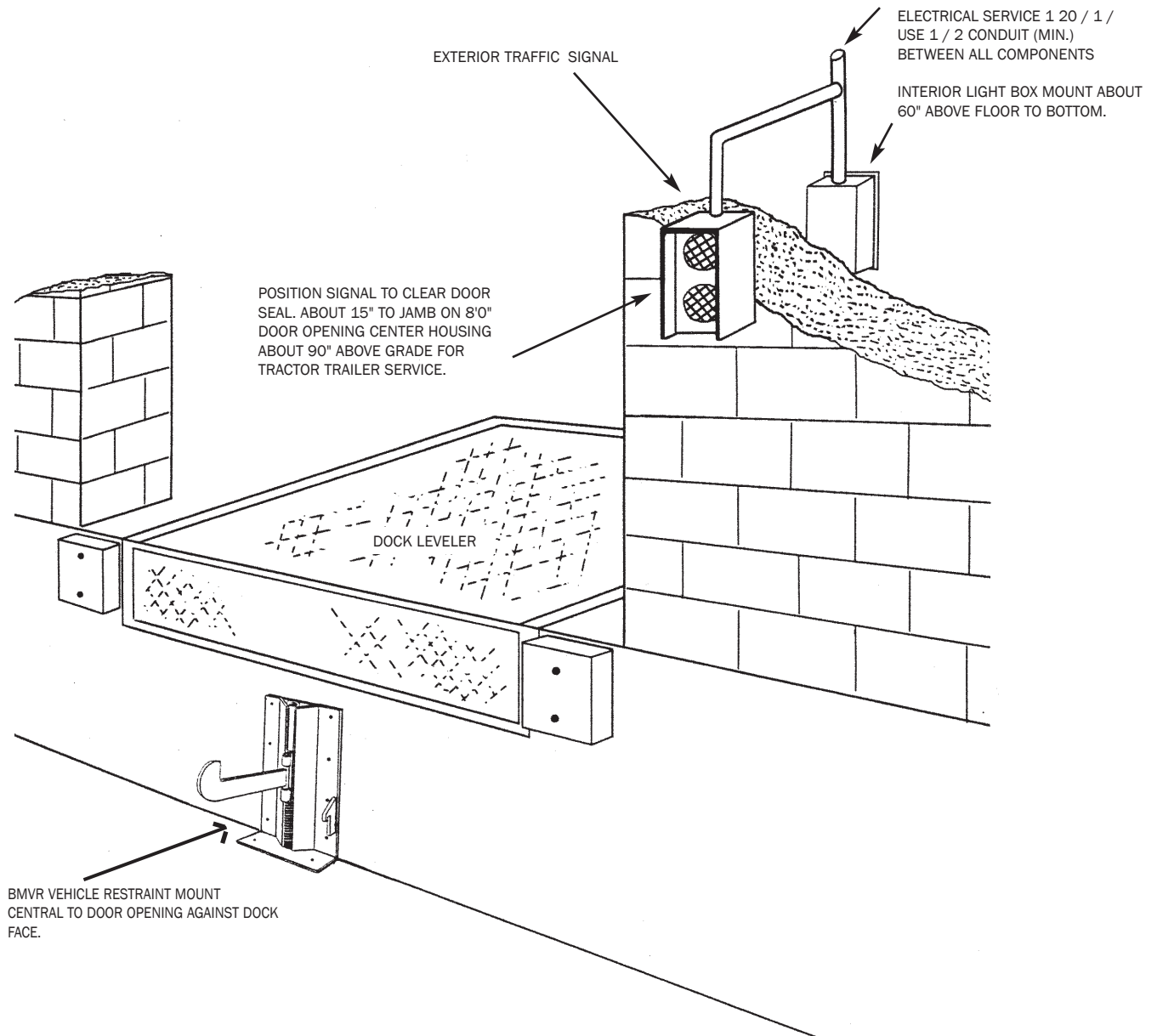

# "BMVR" Series Mechanical Truck Restraint Submittal Drawing

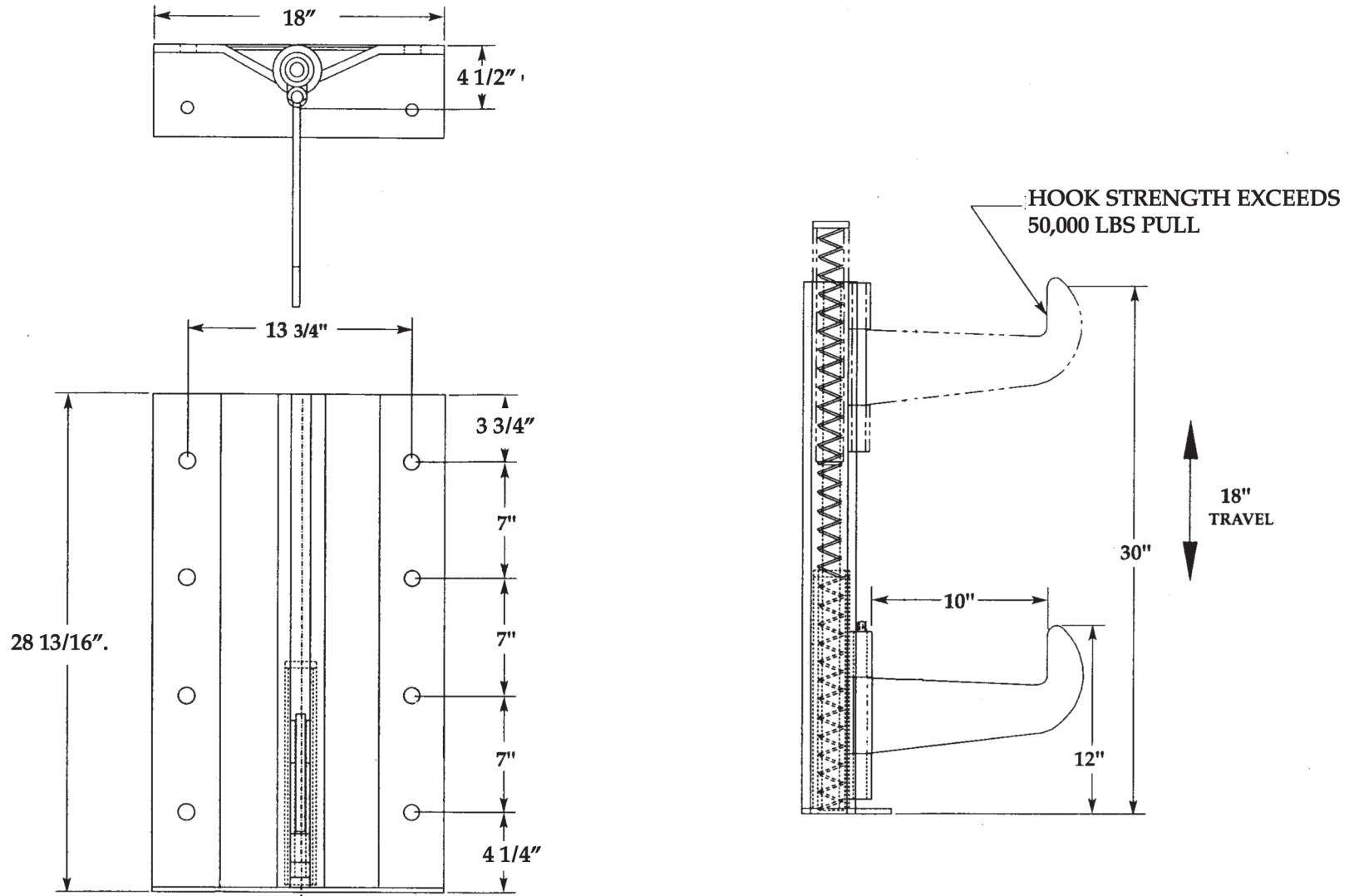

# ARRANGEMENT OF THE DOCK AREA

**NOTE:** Attachment of this unit places anchor components in shear and tension rather than direct tension for added strength. Your best results will be achieved when all mounting holes are used.

## OPTIONAL INSTALLATION NEEDS:

**New Construction:** Preplanned use of the BMVR will afford the opportunity to use a cast in place anchor plate offered by BEACON or prepared by others to become a fixed component of the dock face. These plates offer maximum strength and ease of installation. When imbedded in a new wall or during remodeling, the BMVR becomes a weld-on installation.

**Leveler Overhang:** Should building design offer a cantilevered dock shelf, extended bumpers or dock end mounted leveler (Edge-of-Dock product), the BMVR Restraint console must be mounted ahead of the dock wall a distance equal to the location of the dock bumper face from the foundation wall, less 4". The console size is designed to accommodate

industry standard 4" – 6" dock bumperring. Any bumper projection more than 6" from dock face necessitates console positioning ahead of dock wall. BEACON will prepare the BMVR per order to satisfy your dock conditions if known in advance. BEACON can also prepare field adapters for these mounting needs. Discuss with your representative or local fabricator as on-site conditions require.

**Cinder Block Wall:** Usually a block wall offers minimal longevity to face mounted equipment. It is, therefore, necessary to take added measures to assure improved anchoring. A face plate welded to pit slab curb steel and extending to grade level with extra anchoring will be beneficial, allowing for a weld-on installation of the BMVR. Additionally, firm foot anchoring is highly recommended. If a concrete approach is not available, a pad should be prepared 8" deep by 6' wide by 4", with two layers (separated) of reinforcement mesh not less than 4' by 4'. A cast-in anchor base is also recommended for weld-in place installation in these situations.

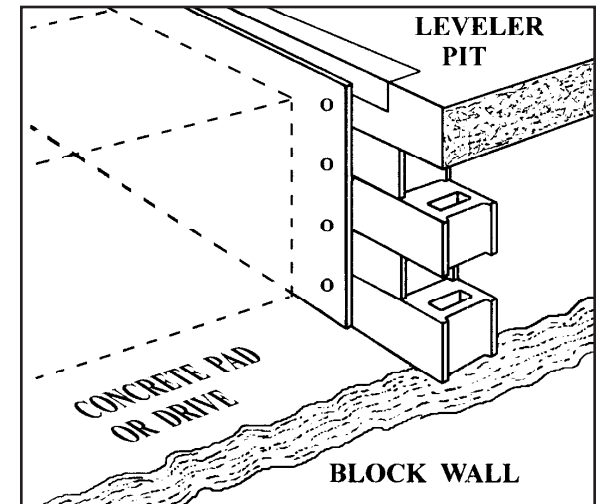
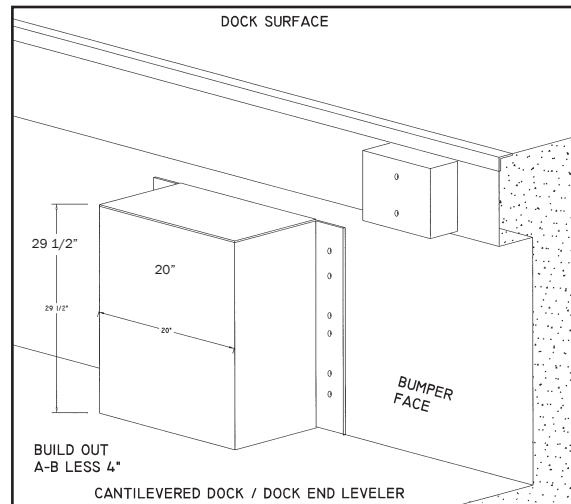
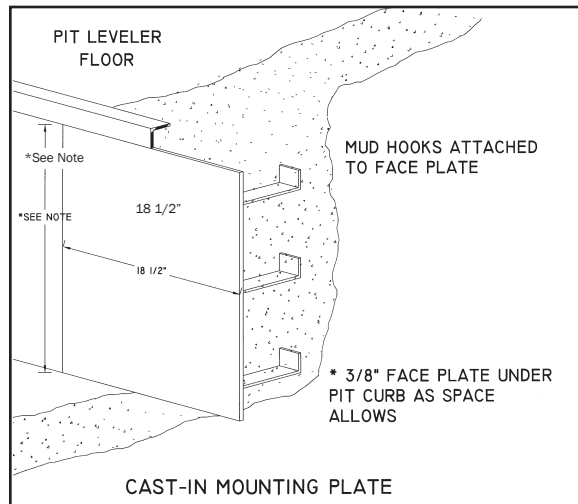

## SECTION 1 INSTALLATION PROCEDURE

Read and understand all instructions prior to installation or operation of this safety equipment.

The BMVR is shipped completely assembled and factory-tested. This product displayed proper operation under factory conditions prior to shipment and is ready to install. Inspect all materials received and review arrangement layout included to preview installation setup needs.

Review the dock face area directly beneath the location where truck docking occurs. Remove or relocate any obstacles which would prevent flush and secure mounting of this product. Repair any weakness observed in the mounting area. If conditions warrant, prepare a slab for base mounting of the BMVR.

**NOTE:** Base mounting in conjunction with wall mounting provides the ultimate opportunity to maximize the installed strength of this safety equipment and is highly recommended particularly when wall conditions may not be optimum. However, local conditions including floating yard slabs or poor drive construction may negate or minimize the value of this feature. Particular attention should be given other opportunities to offer a maximum installed strength of this product in the event a portion of the prescribed installation method requires deviation from that noted. (See list of optional mounting alternatives.)

Position Restraint console and mark dock face and grade for anchors. Unit should be positioned to sit plumb (vertical) and level (horizontal) and as firmly against dock face as possible. Shim beneath bottom mounting rails as needed to provide firm footing. Shims should be steel and welded into position to avoid creepage or accidental dislocation. This unit is prepared for 5/8" diameter anchors. Minimum length recommended is 5" for wedge type anchors. (See other instructions if dock is not poured concrete construction.) Eight (8) hole locations are provided for wall attachment and should all be prepared for anchors.

Grade attachment should be offered as allowed by conditions. Use same technique as wall mount if yard has concrete pad or drive. Compensate length of anchor for any shim addition under mounting plate. For black top or hard compacted drives provide anchor rods of 1/2" diameter by about 15" long.\* These should be prepared with a modestly pointed nose to be driven into the ground surface through the mounting holes offered. The top end should then be welded to secure rod to Restraint base.

The operating range of the BMVR offers engagement of most legally mounted ICC frame members. The unit performance will be limited to the position and strength of the ICC frame section which varies by manufacturer and design as well as its condition due to the extent of its maintenance, age and possible abuse. The BMVR will accept very high stress and pulling forces, however, this too can be limited by installation technique, anchors and materials and/or the condition of the dock wall and drive area. Conditions or equipment failure due to accident or inadequate preparations and/or reasonable maintenance of the dock area and its equipment could result in further property damage or personal injury.

\*Use 1/2" diameter rebar or similar for good grip characteristics.

**NOTE: Where possible, weld the back of the restraint to the embedded curb angle at the front/leading edge of the pit leveler.**

## **SECTION 2 INSTALLATION INSTRUCTIONS**

### **MOUNTING INSIDE AND OUTSIDE LIGHTS**

Mount Inside Light Package (BMVR 103 & BMVR 105) to convenient location which provides a good view for dock attendant of loading area. We recommend left side of opening looking “out” as shown in dock arrangements diagram as this simplifies installation. Right side of doorway mounting is fine if installation conditions warrant.

Mount exterior traffic light on truck driver’s side of exterior wall (left side facing out) in area clearly visible to driver. Be certain to offer clearance for future or current installations of seal/shelter products. Light housing should be 8 – 9' above grade as noted on arrangement diagram.

Route conduit (BMVR 103 & BMVR 105) and connectors (supplied by electrical installer) to join inside and outside light box (wire also to be supplied by installer). Make connections per diagram provided in light package.

Install trucker’s instruction signs above and below traffic light where clearly visible to incoming traffic.

Supply and connect incoming electrical power light boxes per enclosed diagram.

# BMVR 103

## AC 115V SG30 STOP & GO WIRING DIAGRAM

### SG20-115V CONTROL UNIT

NOTE: WIRING IS THE SAME FOR INCANDESCENT AND LED FIXTURES

4 WIRE CABLE FROM SG30 TO SG10

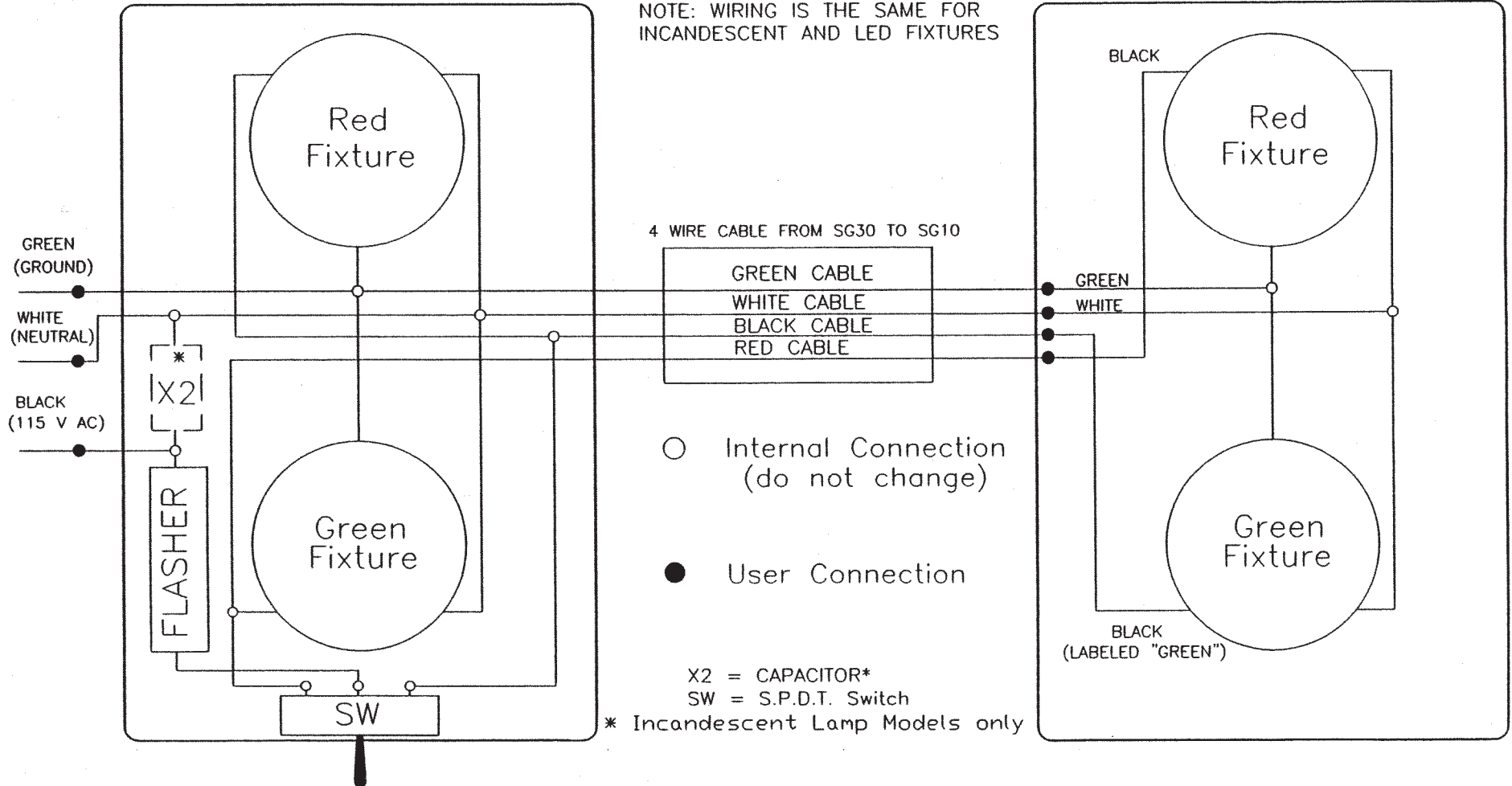

GREEN CABLE  
WHITE CABLE  
BLACK CABLE  
RED CABLE

○ Internal Connection  
(do not change)

● User Connection

X2 = CAPACITOR\*  
SW = S.P.D.T. Switch

\* Incandescent Lamp Models only

# BMVR 105

## AC 115V SG30 STOP & GO WIRING DIAGRAM (WITHOUT SWITCH—FOR EXTERNALLY CONTROLLED CIRCUITS)

SG20NS-115V CONTROL UNIT

SG10-115V DRONE UNIT

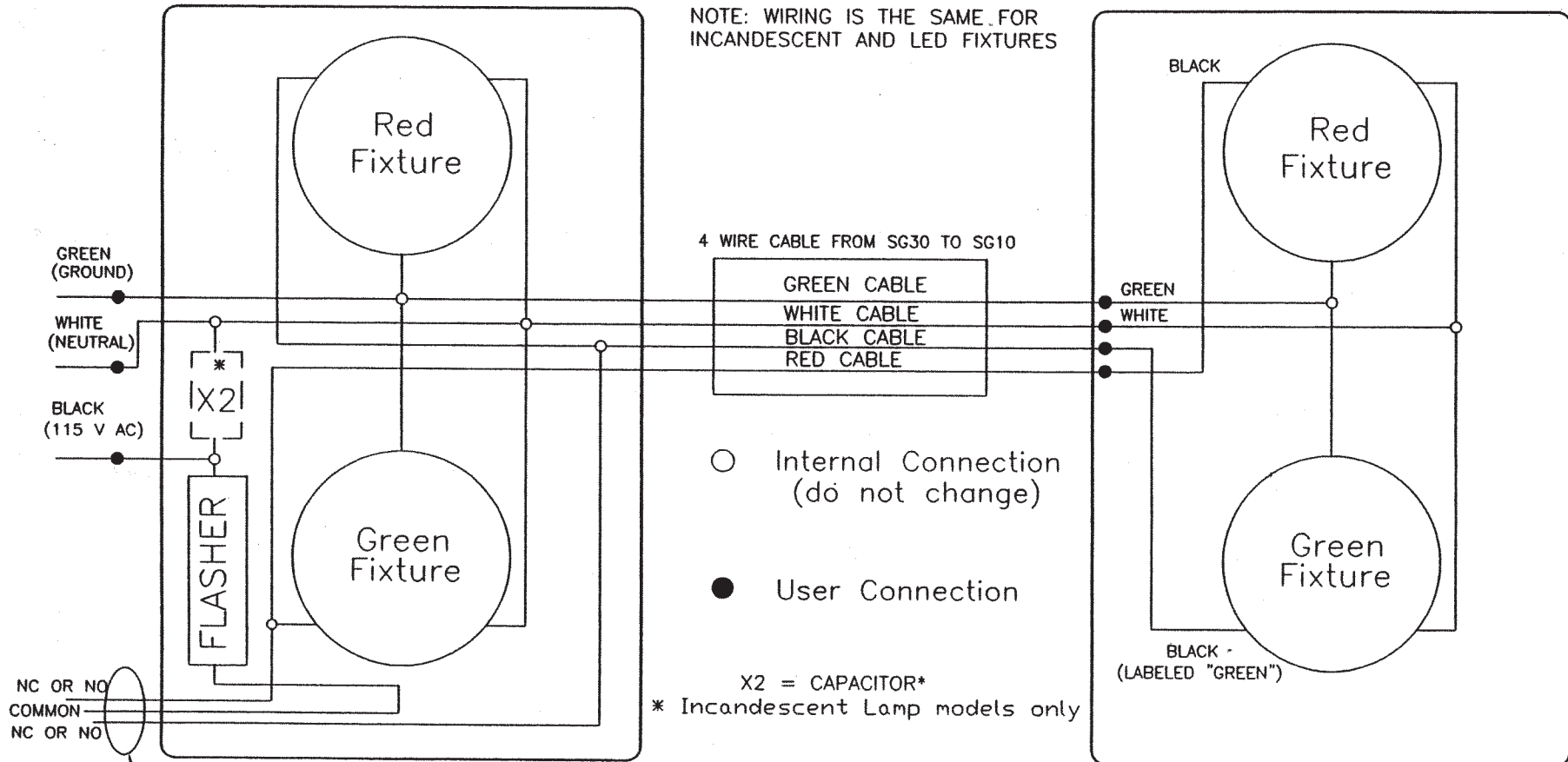

Three wires to external switch:  
Common connection is WHITE wire.  
GREEN lamp connection is BLACK wire with 'GREEN' tag.  
RED lamp connection is BLACK wire with no tag.

# BEACON LOADING DOCK EQUIPMENT

## BMVR105

### ELECTRIC SCHEMATIC

#### WITH FLASHER

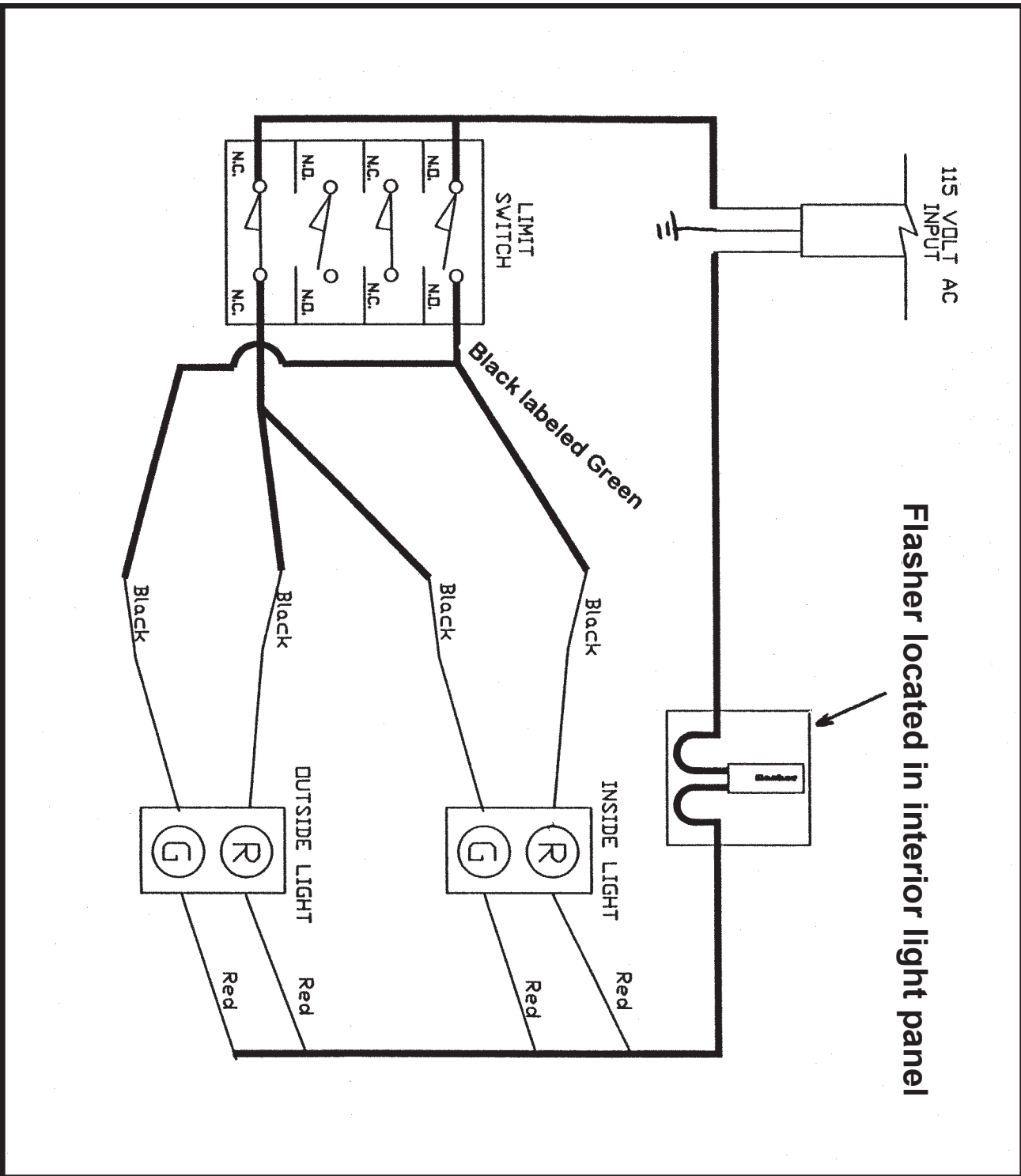

## **SECTION 3 ADJUSTMENTS**

Properly installed and serviced this Vehicle Restraint will greatly enhance safety during truck loading/unloading operations and should offer many years of service without a regular maintenance schedule. This product is designed for use in the outdoor environment. Regional and seasonal climate variables offer a wide range of maintenance possibilities for equipment exposed to the elements. The factory adjustment of this product offered proper operation prior to shipment. Although the factory attempts to offer equipment which will display normal operation for most installations, local conditions may require attention at installation to cope with specific site needs.

Please contact the factory to review any installation or equipment issue which is not covered by this manual or which is not fully understood.

Contact your authorized BEACON representative for required service or adjustments.

## SECTION 4

## OPERATION

The BEACON BMVR Vehicle Restraint uses a simple extension spring to engage and disengage the locking hook of this unit. This system eliminates the need for regular maintenance although an adjustment as previously noted may be in order. The Restraint hook is activated and retracted as follows:

With the truck docked firmly against the bumper face, the dock attendant simply engages the activation rod to push down and turn the hook so that it can rise and engage the ICC bar. He then flips the switch (BMVR 103) on the inside light box and the exterior traffic signal will switch from green to red (the BMVR 105 lights will change automatically via a limit switch) to advise the trucker not to attempt a departure. The inside light will switch to green to advise a good loading condition. A brief check of the engagement should show the ICC frame entrapped by the restraining hook of the BMVR. If the truck is noted to have a weak or missing ICC

frame the attendant should advise supervision of the noted problem and see that other measures are taken to secure the truck prior to loading or unloading. The BMVR should remain engaged to offer a secondary opportunity by controlling truck traffic with its exterior traffic light.

When the truck is ready to depart, the dock attendant engages the activation rod, pushes down on the hook and turns it to the left to secure it. He then flips the manual switch (BMVR 103) on the inside light box and the exterior traffic light will switch from red to green to release the docked truck; (the BMVR 105 lights will change automatically via a limit switch) and the interior visual display will switch to red to advise caution around the dock area because the BMVR is now deactivated and the truck may leave at any time.

## SECTION 5

## MAJOR COMPONENTS

**Restraint Console:** A heavy steel housing, to enclose the operating components of the BMVR, serves as the mounting framework for the unit installation. The console is offered for grade level mounting against the dock wall face. Alternate mounting options are available to satisfy unique local conditions.

**Restraint Hook:** Operates to engage the ICC frame section of the truck or trailer chassis. When engaged the Restraint hook offers resistance to truck movement. When disengaged the Restraint hook is stored flat against the housing to allow free passage of docking or departing vehicles.

**Extension Spring:** The BMVR is activated by an extension spring and stored to the side by pushing down, turning to the left and releasing hook to engage storage hook.

**Activation Bar:** Bar is stored away from unit and is uniquely constructed to act as neutral counterbalance to activation spring.

**Interior/Exterior Traffic Lights:** High impact polymer enclosures for housing red and green visual traffic control indicators to display docking or no-go conditions for trucker. To open light housing, screw clamps must be loosened to service lights or wiring.

## SECTION 6

## SPECIFICATIONS

**Electrical:** 120V AC, 20A.

**Wiring:** Refer to field arrangement drawing (Page 1) for conduit and wire needs. Wiring diagram included in light box.

**Limit Switches:** Industrial quality momentary contact type. Used to control traffic signals and stop cycle in motor control circuit. (BMVR 105)

**Interior/Exterior Lights:** (Red and Green) Sealed beam lamps, 120V.

**Red LED lens:** Part No. 9489

**Green LED lens:** Part No. 9488

## SECTION 7

## MAINTENANCE

**Maintenance Procedure:** Shut off electrical power before lamp replacement.

**Quick Check:** Are all lamps on when required in cycle?

**Visual Indicator:** Proper traffic signals are critical to this safety equipment. Review functions on Page 7. Verify correct lamps on/off during lock/unlock cycles. See specifications on this page for replacement bulbs. Shut power off before lamp replacement.

**Lubrication:** This product is designed to function without excessive lubrication. However, a squirt of white lithium grease or similar product on hook slide will help promote a smooth operation.

## **WARRANTY**

**BEACON INDUSTRIES, INC. guarantees its BMVR Series Truck Restraint to be free from defects in materials and workmanship for a period of one (1) full year from date of shipment.**

**A claim for breach of warranty will be honored if the product has been properly installed, maintained and operated and not damaged by abuse.**

**BEACON will exchange or repair any structural component found to be defective in nature.**

**BEACON INDUSTRIES, INC. SHALL NOT BE LIABLE FOR LOSS OF USE OF ANY EQUIPMENT OR INCIDENTAL DAMAGES.**

### **CAUTION:**

Contact your BEACON representative or the factory if a malfunction occurs which is not understood. DO NOT attempt to correct the situation without proper information and understanding, as this may damage components and void the warranty.

---

### **SERVICE AND MAINTENANCE**

BEACON recommends periodic inspection and servicing of the BMVR Truck Restraint to assure proper operation and maximum life span of the unit. Units should be inspected a minimum of every six months, and if needed, can be adjusted and lubricated. Contact your local BEACON dealer to secure a complete maintenance plan.