

# OWNER'S MANUAL

## HYDRAULIC BOX DUMPER series BHBD

### Contents

Warnings and Safety Instructions .....	1	Electrical Schematic (1-4K) .....	7
Receiving Instructions .....	1	Electrical Schematic (6K) .....	8
Installation Instructions .....	2	Hydraulic Schematic .....	9
Routine Maintenance Instructions .....	2	Exploded Parts Drawing .....	10
Operation Instructions .....	3	Parts List .....	11-12
Power Unit Operation .....	4-5	Troubleshooting Guide .....	13
Air Bleed Instructions .....	5	Warning Label Identification .....	14
Motor and Transformer Diagram .....	6	Limited Warranty .....	15

### WARNINGS & SAFETY INSTRUCTIONS

**Ensure that all employees understand and follow the following instructions!!!**

- Read and understand the owner's manual before using or servicing the dumper.
- The load must be removed from the chute and the chute fully lowered before any work is performed on the lift.
- Ensure that all safety and warning labels stay in place and are legible. See the label page in this manual.
- The dumper's frame must be securely anchored to the floor. See the installation instructions.
- Do not use the dumper if any damage or unusual noise is observed.
- Always watch the chute and the barrel carefully when the dumper in operation.
- Do not perform any modifications to the dumper without the manufacturer's approval. Failure to receive authorization for changes to the equipment could void the warranty.
- Maintenance and repairs are to be done only by personnel qualified to perform the required work.
- Do not use brake fluid or jack oils in the hydraulic system. If oil is needed, use an anti-wear hydraulic oil with a viscosity grade of 150 SUS at 100°F, (ISO 32 cSt @ 40°C), or Dexron transmission fluid.
- Use only replacement parts either supplied or approved by the manufacturer.

Remove all packing and strapping material. Inspect for damage. IF DAMAGE IS EVIDENT, FILE A CLAIM WITH THE CARRIER IMMEDIATELY! Also, check the unit size, type of power unit, etc., to ensure the dumper is correct for the intended application.

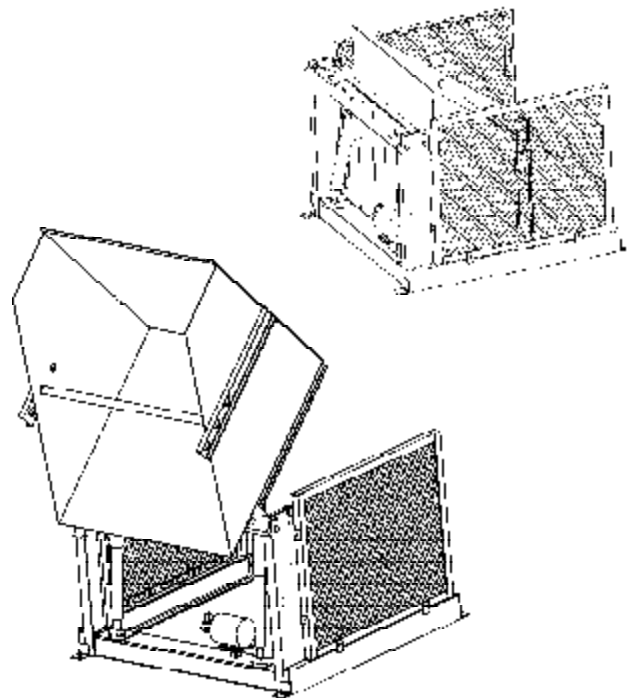

**HYDRAULIC BOX DUMPER  
SERIES BHBD**

### RECEIVING INSTRUCTIONS

Every unit is thoroughly tested and inspected prior to shipment. However, it is possible that the unit may incur damage during transit. If you see damage when unloading, make a note of it on the BILL OF LADING.

---

## INSTALLATION INSTRUCTIONS

*Review this entire page before installing the dumper.*

*Consult the factory in the event there are questions or problems at the time of installation.*

The installation must be made in compliance with all the regulations applicable to the machine and its location. The installer must verify that the equipment is installed so it will be suited to the environment in which it will be used.

Installation must be performed by suitably trained personnel with access to the proper equipment. The electrical aspects of the installation should be performed by an electrician.

### **For installation you will need the following:**

1. A forklift.
  2. Lag bolts, a masonry drill, a masonry bit a wrench to fit the lag bolt nuts, grout and steel shims. Consult the building's architect or facility engineer to determine the best size and type of hardware with which to anchor the machine to the floor.
  3. A power supply circuit matching the motor voltage and current requirements. Refer to the labels on the control enclosure and the electrical section in this manual for more information. The end-user is responsible for supplying the branch circuit's required overcurrent and short-circuit protection.
- 
1. Move the dumper into place with a forklift.
  2. Anchor the frame to the floor through the 5/8" holes in the tie-down brackets located near the corners of the frame.
  3. Shim and/or grout under the full length of the frame sides.
  4. Make the required power supply connection.
  5. Operate the dumper through several full up / down cycles. Verify that the upper travel limit switch and the lower travel limit switch (if applicable) function properly.
  6. Check the hydraulic oil level. It should be filled to within 1" to 1-1/2" of the reservoir's fill hole. Refer to the hydraulic section in this manual for more information.
  7. Clean up any debris or spilled oil, and verify that all of the warning and safety labels are intact.

---

## ROUTINE MAINTENANCE & SAFETY CHECKS

- Care should be taken to identify all potential hazards and comply with applicable safety procedures before beginning work.
- Fully lower the chute to the floor before beginning any inspection or work on the unit.
- Only qualified individuals trained to understand mechanical devices and their associated electrical and hydraulic circuits should be attempt troubleshooting and repair of this equipment.

### **(A) Before each use inspect for the following:**

1. Frayed wires
2. Oil leaks
3. Pinched or chafed hoses
4. Damaged or loose hold-down tube or socket.
5. Damage or structural deformation to the structural members, the cylinder brackets, etc.
6. Unusual noise or binding, or evidence thereof.
7. Proper functioning of all limit switches.

### **(B) Monthly Inspections:**

1. The oil level. Oil should be 1" to 1-1/2" below the reservoir's fill hole with the chute fully tilted.
2. Worn or damaged hydraulic hoses and electrical wires.
3. Proper operation of the barrel hold-down clamps.
4. Pivot point wear at the hinge pins and cylinder ends.
5. Intact pin and clevis retaining rings and/or fasteners.
6. Frame anchor bolts' tightness, and for cracks in the concrete around them. (Stationary units only.)
7. Looseness, wear, or damage to the casters' bearings, mounting hardware, or surface material. (Portable units only.)
8. Proper water level in the battery. (DC units only)
9. Unusual noises.
10. Information and warning labels being in place and in good condition.
11. The need to clean off dirt and debris.

### **(C) Yearly Inspections**

The oil should be changed if the oil darkens, becomes gritty, or turns a milky color (indicating the presence of water). Replace with an anti-wear hydraulic oil with a viscosity grade of 150 SUS at 100°F, (ISO 32 cSt @ 40°C). Ex: AW-32 or HO 150 hydraulic fluid, or Dexron transmission fluid.

---

## **OPERATION INSTRUCTIONS**

### **LOADING:**

The box dumper is designed for loads in open-topped box containers measuring at least 1/2 as wide and 3/4 as deep as the chute when loaded into the chute.

Insert the container so it is against the back of the chute. Insert the hold-down tube into the appropriate sockets in the sides of the chute to prevent the container from sliding when dumped. The container should never be more than 5" below the hold-down tube.

The load rating is shown on the machine dataplate located on the right-side upright frame channel (typically just above the push-button control hanger). It indicates the net capacity of the dumper. Permanent damage to the lift or injury to personnel could result from exceeding the listed capacity.

### **OPERATION:**

The lift is furnished with a constant pressure (dead-man style) push-button control.

Pressing the "UP" push-button will turn on the power unit to raise the chute. The chute will raise only while the control is pressed. Upon releasing the control, the chute will stop and hold its position. A limit switch will turn off the motor when the chute reaches its maximum rotation angle.

Pressing the "DOWN" push-button will energize the lowering valve (1-4 K) or turn on the power unit (6K) to allow the chute to descend. Again, releasing the control will stop the chute movement, and the unit will hold its position. On 6K units, a limit switch will turn off the motor when the chute has fully lowered. Be certain no part of any person or object is under any part of the chute before lowering it.

In the event that the load exceeds the dumping capacity, the hydraulic system's relief valve will open and not allow the unit to lift.

### **SAFETY:**

- Keep all personnel clear of the machine when it is in operation.
- Always load the unit properly.
- Regularly inspect the hold-down tubes and the sockets in the sides of the chutes.
- Never use the dumper if it is in need of repairs or if it seems to be malfunctioning.
- Notify your maintenance personnel if you notice anything out of the ordinary, such as odd noises, erratic motion, or damage to any part of the lift or its components.

### **ORDERING REPLACEMENT PARTS:**

- We take pride in using quality parts on the equipment we manufacture. We are not responsible for equipment problems resulting from the use of unapproved replacement parts.
- To order replacement or spare parts for this equipment, contact the factory.
- In any communication with the factory please be prepared to provide the machine's serial number, which is indicated on the machine dataplate.

---

## POWER UNIT'S OPERATION

The electric / hydraulic box dumper utilizes an electric motor directly coupled to gear-type hydraulic pump to produce the needed fluid pressure and flow to allow the cylinders to perform the work of dumping a box container.

A hydraulic manifold houses the hydraulic control components, and is bolted directly onto the gear pump.

The power unit's hydraulic components are all rated for 3,000 psi working pressure.

### IMPORTANT PARTS OF THE POWER UNIT INCLUDE:

- **The electric motor.** Motors are available for operation on single or three phase AC supplies (all are dual-voltage capable).
- **The gear pump.** Its shaft is coupled directly to the shaft of the electric motor. Several displacements are available, depending on the motor horsepower used.
- **The check valve (1-4K).** Its purpose is to prevent the backflow of fluid through the pump. In this way it allows the platform to be held at a given elevation indefinitely.
- **The pressure relief valve.** Its job is to open a path for fluid to flow back to the reservoir in the event that the fluid pressure built up by the pump exceeds 3,000 psi. Thus the system cannot see more than 3,000 psi.
- **The lowering solenoid valve.** This is an electrically-operated cartridge valve. It contains a screen to keep contaminants from entering the valve.
- **The counterbalance valves (6K).** These valves allow for smooth motion in double-acting hydraulic circuits.
- **The pressure-compensated flow control spool (1-4K).** This rests under the lowering valve, and regulates the fluid flow back to the reservoir when the valve opens. It allows the table to always lower at the same rate regardless of whether there is a load on the platform or not. Several sizes are available.
- **The hydraulic lift cylinder(s).** Displacement-style (1-4K), or double-acting (6K) cylinders. The displacement style have a bleeder valve located at their top end to allow air to be bled from the hydraulic system.
- **The safety velocity fuse.** This is a device that is installed in the cylinder's hose port. It closes quickly in the event of a claustrophobic hose failure to prevent the chute from collapsing down. The chute remains stationary until pressure is reapplied to the system.
- **The hydraulic fluid.** The system uses HO150 hydraulic fluid. Any anti-wear hydraulic fluid with a viscosity grade of 150 SUS at 100°F (ISO 32 @ 40°C) such as AW-32 or Dexron transmission fluid are acceptable.

WHEN THE CHUTE IS TO BE TILTED, PRESS THE "UP" PUSH-BUTTON. THE MOTOR TURNS, AND IN TURNING IT SPINS THE HYDRAULIC GEAR PUMP. OIL IS DRAWN FROM THE RESERVOIR THROUGH THE SUCTION FILTER AND INTO THE PUMP:

- **For 2K & 4K capacities.** The pump pushes the pressurized oil through the check valve and out to the lift cylinders.
- **For 6K capacity:** The pump pushes the pressurized oil through the energized directional valve RT and into the blind end of the lift cylinders. Oil is pushed out to the cylinders' rod end and through counterbalance valve 2CB, which prevents the chute from jumping when it nears the highest point of its rotation.

Releasing the push-button at any point will stop the rotation, and the chute will hold at that tilt angle.

An upper travel limit switch turns off the motor when the chute is at its full tilt angle.

WHEN THE CHUTE IS TO BE LOWERED, PRESS THE "DOWN" PUSH-BUTTON:

- **For 2K & 4K capacities.** The lowering valve opens, bypassing the check valve and allowing the oil in the cylinders to return back to the reservoir through the return hose. The rate at which the platform lowers is regulated by the internal pressure-compensated flow spool.
- **For 6K capacity:** The motor turns the pump pushes the pressurized oil through the energized directional valve LT and into the rod end of the lift cylinder. Oil is pushed out of the cylinders' blind end and through counterbalance valve 1CB, which regulates the speed and smoothness with which the chute lowers. A limit switch turns off the motor when the chute is fully lowered. Releasing the push-button at any point will stop the rotation, and the chute will hold at that tilt angle.

CONTINUED ON NEXT PAGE...

---

## POWER UNIT'S OPERATION - continued

IN THE EVENT THAT THE CHUTE CREEPS DOWN SLOWLY AFTER RELEASING THE "DOWN" CONTROL, IT WILL BE NECESSARY TO REMOVE THE LOWERING CARTRIDGE VALVE FOR INSPECTION AND CLEANING, AS FOLLOWS:

- Lower the chute until it is fully lowered.
- Remove any load from the chute.
- Remove the nut holding solenoid coil on the valve stem, then remove the coil, and then unscrew the valve from the manifold.
- Inspect the valve for contaminants, and the valve's o-rings and backup washers for cuts, tears, or other damage.
- With the valve immersed in mineral spirits or kerosene, use a thin tool such as a small screwdriver or a small hex wrench to push the poppet in and out several times from the bottom end of the valve. The valve should move freely, about 1/16" from closed to open position. If it sticks in, the valve stem could be bent and will need to be replaced if it doesn't free up after cleaning. Blow the valve off with a compressed-air gun while again pushing the poppet in and out.
- Inspect the bottom of the manifold's valve cavity for contaminants.
- Again with the thin tool, press on the middle of the flow control spool located in the bottom of the cavity. It should move down and back up freely.
- Reinstall the valve into the manifold, tightening the valve with approximately 20 lb.-ft. of torque.

IF THE PLATFORM LOWERS EXTREMELY SLOWLY, OR NOT AT ALL, THE CYLINDER'S VELOCITY FUSE COULD BE CLOSING. THIS CAN BE CAUSED BY AIR IN THE HYDRAULIC CYLINDERS. TO BLEED THE AIR FROM THE SYSTEM:

- Lower the chute until it is fully lowered.
- Remove any load from the chute.
- Hold a rag over the cylinder's bleeder valve (it looks like a grease zerk) and open the valve about 1/2 turn with a 1/4" or 5/16" wrench. Oil and air will sputter from the valve - once no air is observed, close the valve.

---

## AIR BLEED INSTRUCTIONS FOR DISPLACEMENT-STYLE HYDRAULIC CYLINDERS

When air enters the hydraulic cylinders of the lift, it can often cause undesirable effects.

Some symptoms of air in the cylinders include:

- jerkiness or bounciness when operating the unit;
- a delay before movement begins when the "UP" control (push-button or pedal) is pressed, and;
- locking of the safety velocity fuse(s) in the lift cylinder(s) when the "DOWN" control (push-button or pedal) is pressed, which prevents the unit from lowering.

To bleed the displacement-style cylinders:

If the cylinders are inaccessible with the unit lowered, as with our scissor lift tables, raise the platform and then lower the legs so that they rest on the unit's maintenance props. Otherwise, if the cylinders are accessible with the unit fully lowered, begin with the unit in the lowered position.

Locate the bleeder valve on the top end of the cylinder(s). It will look something like a grease zerk. Use a 5/16" or 3/8" wrench to open the bleeder valve about 1/2 turn and then place a rag over it to contain the oil that will come out with the air when it is bled. Jog the motor by pressing the "UP" control for just a second. If there is air in the cylinder, oil and air should spit and sputter out of the bleeder valve.

Jog the motor several times (wait at least five seconds in-between) until the sputtering stops and only clear oil streams from the bleeder valve. When you're certain all the air has escaped, close the valve(s).

Check the level of the hydraulic fluid in the reservoir. If the oil is not within 1-1/2" of the fill hole, add oil until it reaches that level. The operate the unit and verify that it raises and lowers smoothly.

## MOTOR & TRANSFORMER CONNECTION DIAGRAMS

**CAUTION!** *If the motor voltage is changed, the wire on the control transformer's primary wire has to be changed to match the new motor voltage also.*

MOTOR LEAD CONNECTION DIAGRAM FOR ALL  
.5HP, .75HP AND 1HP SINGLE-PHASE MOTORS AND FOR  
ALL 2HP, 5.5HP, AND 8.5HP THREE-PHASE MOTORS

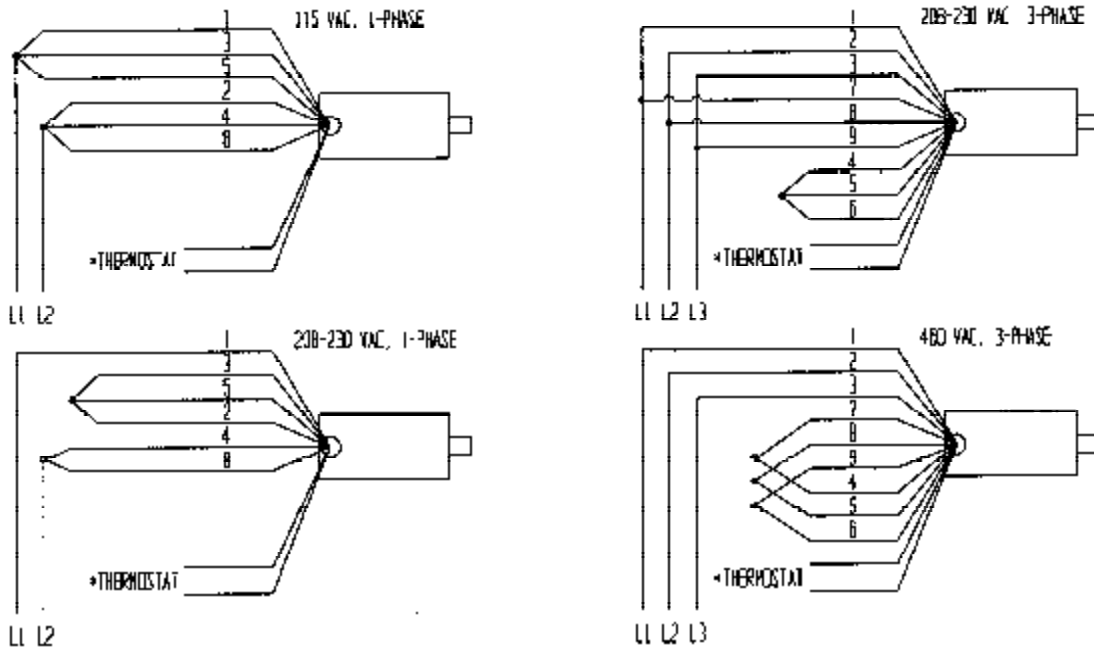

\* The two thermostat leads go to: 1) the grounded side of the transformer secondary, and: 2) the motor relay coil, in either order.



**BE SURE ALL POWER IS OFF BEFORE ATTEMPTING TO WORK ON THIS EQUIPMENT!**

**CAUTION: SERVICE WORK SHOULD BE PERFORMED ONLY BY TRAINED & QUALIFIED PERSONNEL.**

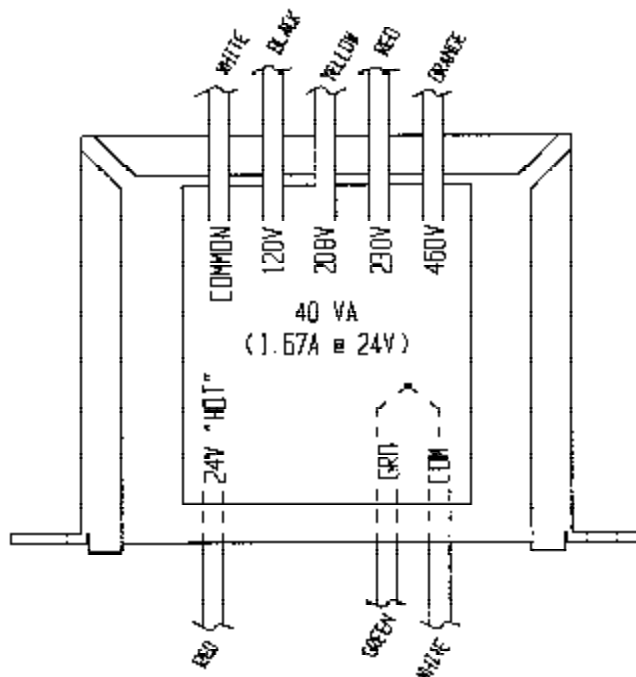

# ELECTRICAL SCHEMATIC for 2,000 & 4,000 lb. Capacity Units

OVERCURRENT & SHORT-CIRCUIT PROTECTION, AND DISCONNECT ARE TO BE PROVIDED BY THE END-USER PER THE NEC (NFPA 70) AND LOCAL CODES.

**NOTES:**

----- Indicates wire and/or components supplied by others

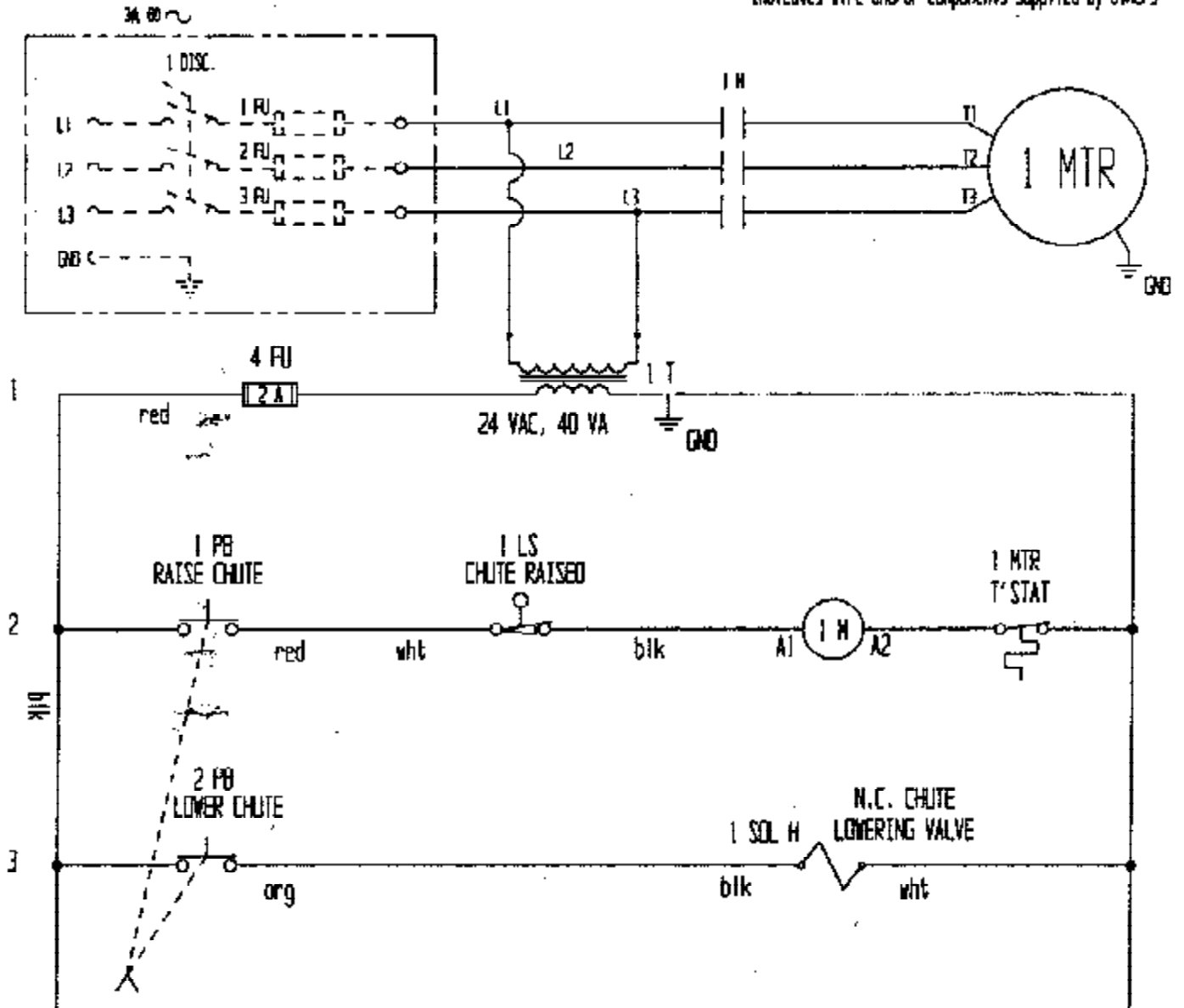

# ELECTRICAL SCHEMATIC for 6,000 lb. Capacity Units

OVERCURRENT & SHORT-CIRCUIT PROTECTION, AND DISCONNECT ARE TO BE PROVIDED BY THE END-USER PER THE NEC (NFPA 70) AND LOCAL CODES.

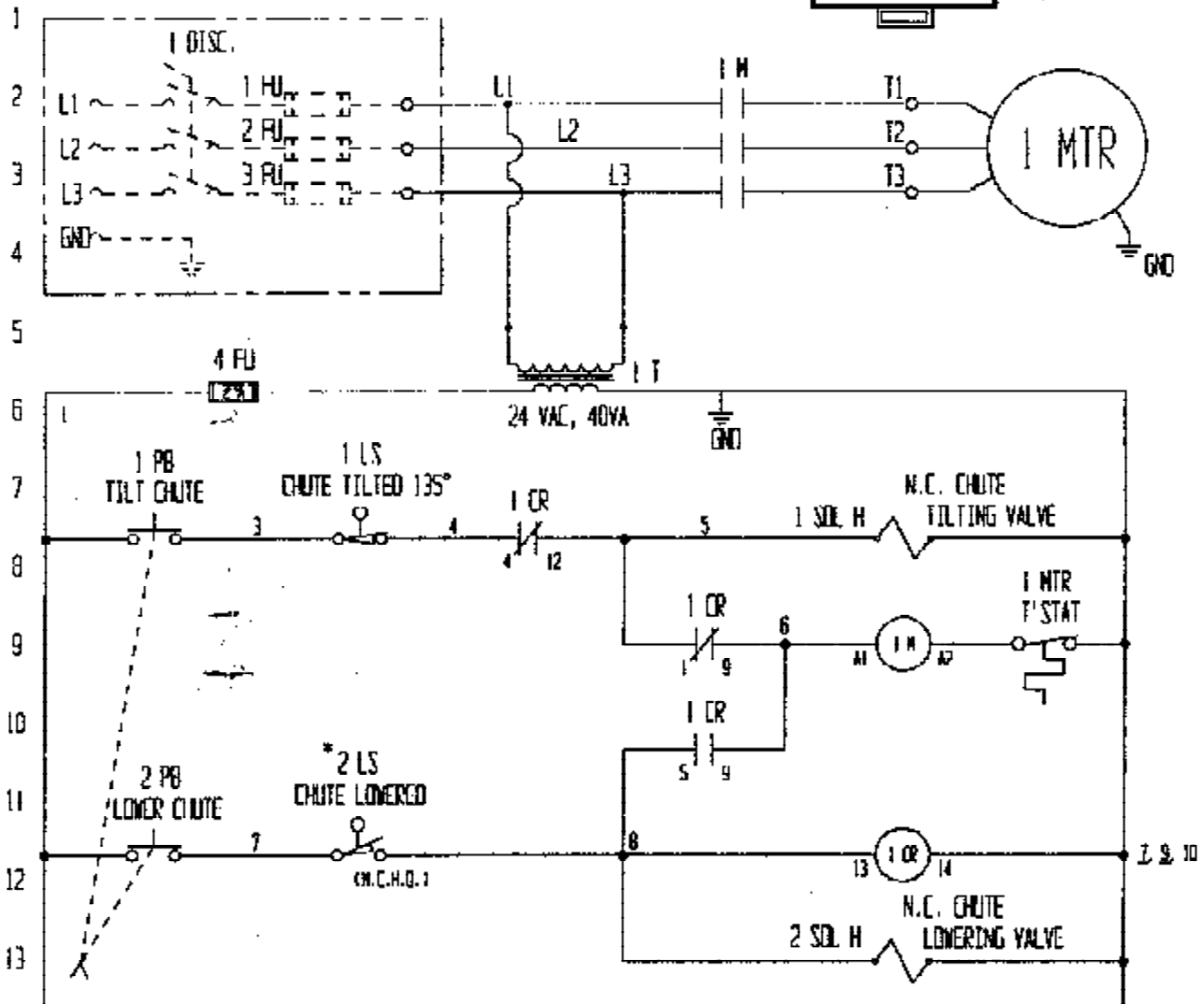
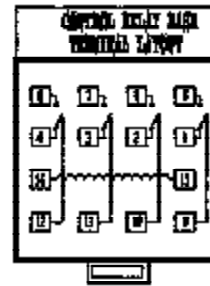

\* ALL COMPONENTS ARE REPRESENTED AS THEY WOULD BE WITH THE CHUTE IN ITS "DOWN", OR RESTING, POSITION. HOME POSITION IS DEFINED TO BE WHEN THE CHUTE IS COMPLETELY LOWERED TO THE FLOOR.

**NOTES:**

----- Indicates wire and/or components supplied by others



**BE SURE ALL POWER IS OFF BEFORE ATTEMPTING TO WORK ON THIS EQUIPMENT!**

**CAUTION: SERVICE WORK SHOULD BE PERFORMED ONLY BY TRAINED & QUALIFIED PERSONNEL**

# HYDRAULIC SCHEMATIC

**2,000 & 4,000 lb.  
Capacity Units**

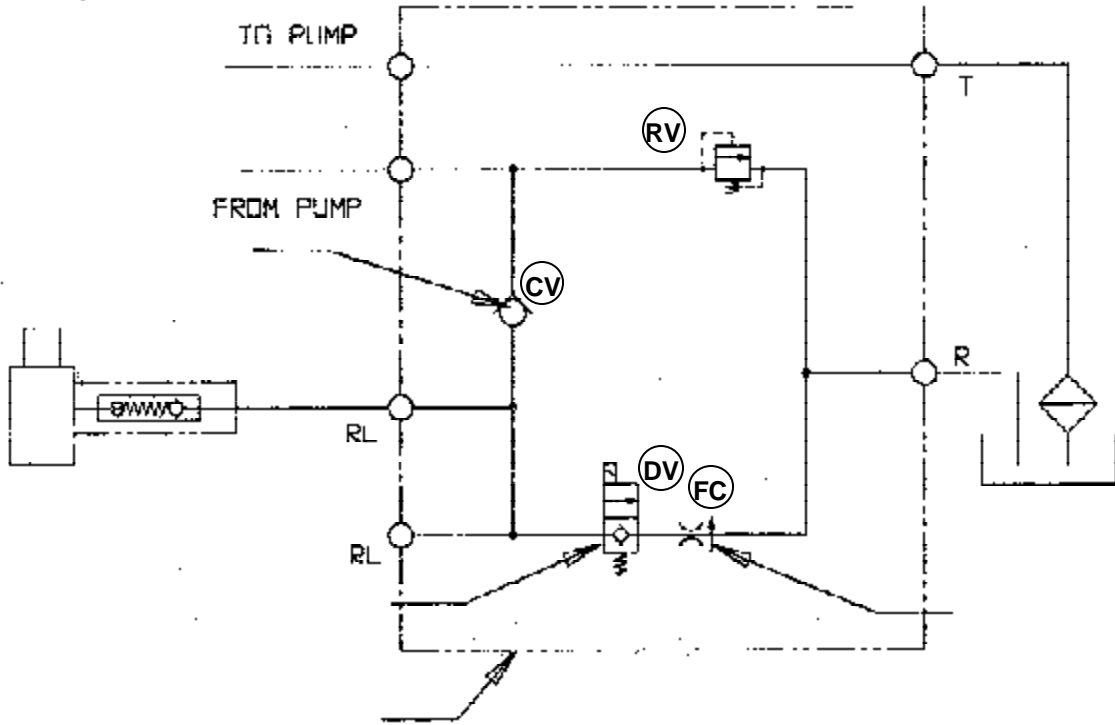

**6,000 lb.  
Capacity Units**

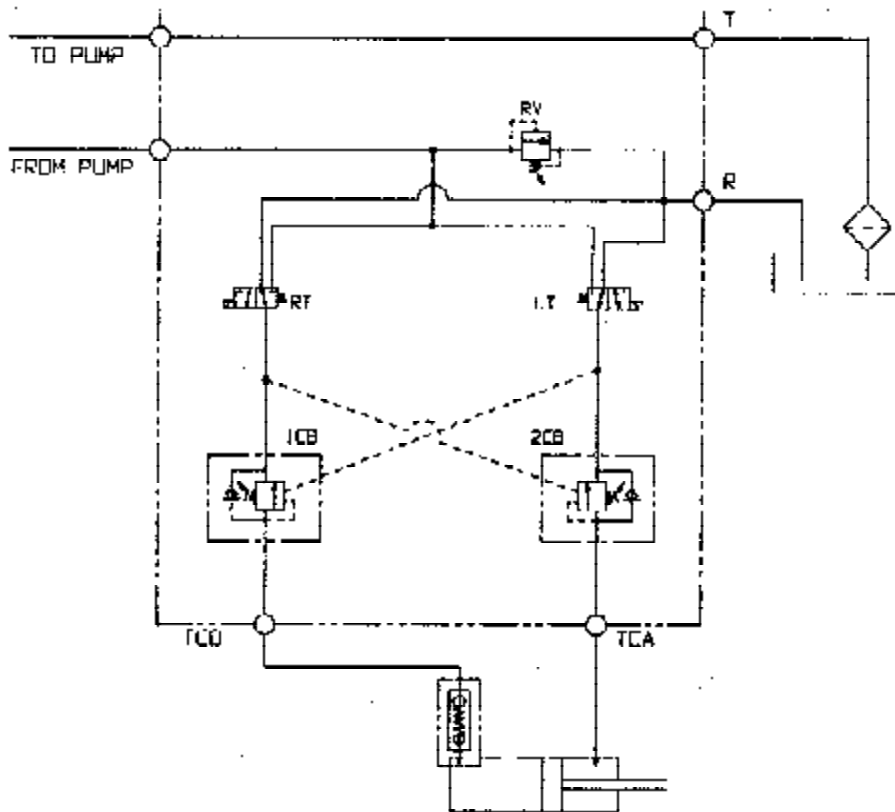

**EXPLODED PARTS DRAWING  
for 2,000 & 4,000 lb. units**

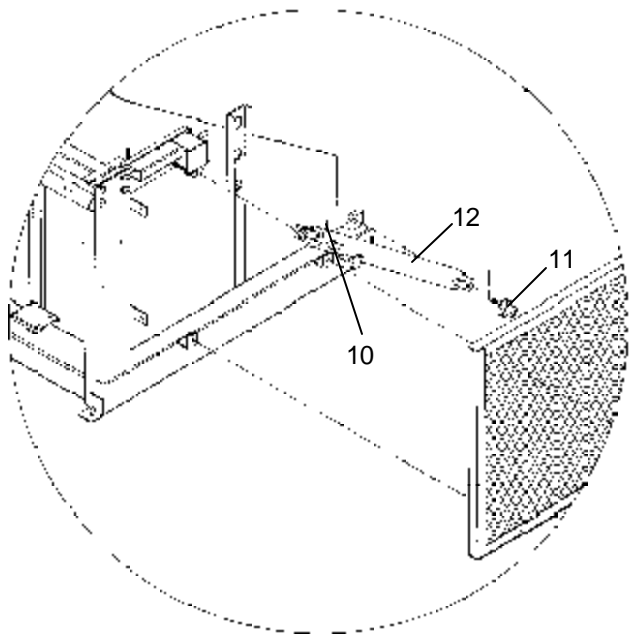
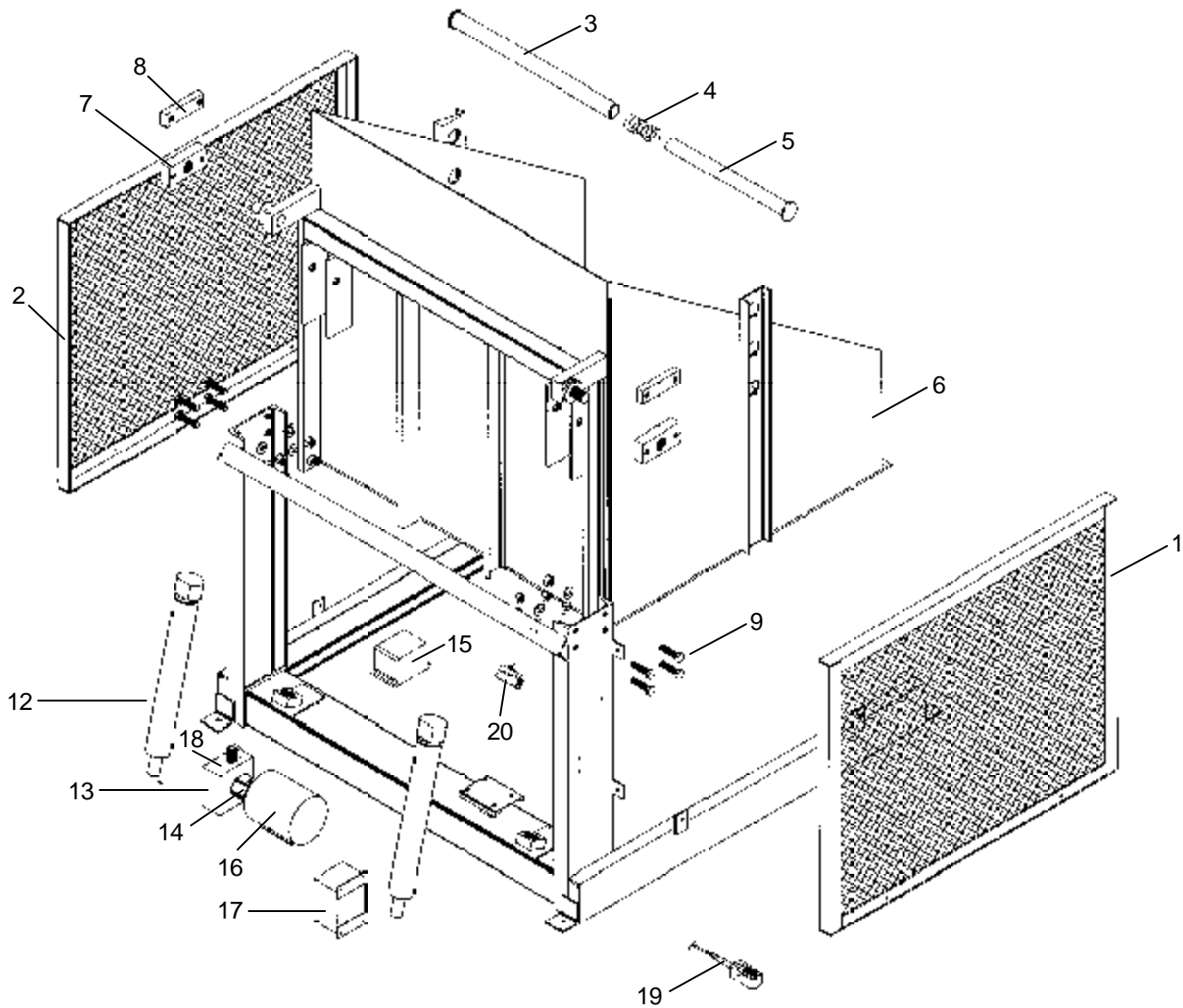

**EXPLODED PARTS DRAWING  
for 6,000 lb. units**

---

## PARTS LIST

*Valid for 1,000 lb. to 6,000 lb. capacities*

ITEM NO.	DESCRIPTION	2,000 & 4,000 lb. PART NO.	6,000 lb. PART NO.	QTY.
1	Guard, Left Side	BHBD-GL	BHBD-GL	1
2	Guard, Right Side	BHBD-GR	BHBD-GR	1
3	Hold-Down Tube, Outer	BHBD-TO	BHBD-TO	1
4	Hold-Down Spring	BHBD-SP	BHBD-SP	1
5	Hold-Down Tube, Inner	BHBD-TI	BHBD-TI	1
6	Chute Assembly	BHBD-CH	HBD-CH	1
7	Hinge Block	BHBD-HB	BHBD-HB	2
8	Stop Block	BHBD-SB	BHBD-SB	2
9	Mounting Hardware	BHBD-MH	BHBD-MH	8
10	Cylinder Split Pin, Upper	BHBD-CU	BHBD60-CU	2
N/S	Cylinder Screw, Lower	BHBD-CS	N/A	2
11	Cylinder Pin	BHBD-CP	BHBD60-CP	2

## ELECTRIC - 1-4K HBD

*Valid for 1-4,000 lb. capacities only. Contact the factory for 6,000 lb. capacity units.*

ITEM NO.	DESCRIPTION	PART NO.	QTY.
16	Motor; varies by customer spec; contact factory	B01-135-XXX	1
17	Control enclosure, 6"W x 6"L x 4"D	B01-029-006	1
17A	Motor contactor, 30A, w/24 VAC coil	BS11.310-24AC	1
17B	Transformer, control; w/24 VAC secondary	B01-129-001	1
17C	Fuse, for control circuit	BAGC 2	1
17D	Cord, power 14/3, 9' long, w/NEMA 5-15 plug (115V units only)	B01-033-015	1
17E	Multipole terminal strip	B159/D	1
18	Solenoid coil, 24 VAC	B99-034-008	1
18A	Connector cord, for solenoid coil	B01-033-017	1
19	Push-button control on 8' straight cord	B01-522-015	1
20	Limit switch, roller-arm (N.C.)	B01-022-001	1

## HYDRAULIC - 1-4K HBD

*Valid for 1-4,000 lb. capacities only. Contact the factory for 6,000 lb. capacity units.*

ITEM NO.	DESCRIPTION	PART NO.	QTY.
12	Cylinder, displacement, 2.5" x 18"	B99-021-909	2
13	Manifold, lift-hold-lower	B99-127-001	1
13A	Valve, relief, 210 bar	B99-153-005	1
13B	Valve, solenoid, N.C.	B99-153-015	1
13C	Valve, check	B99-153-011	1
13D	Flow control spool, 2 gpm	B99-153-024	1
14	Pump, hydraulic, varies by model; contact factory	B01-143-XXX	1
15	Reservoir, 6" x 6" x 16"	B04-023-001	1
15A	Breather plug	BDSP-40-N06	1
15B	Fitting, intake screen	B01-031-005	1
N/S	Hydraulic fluid (gallons)	BHO 150	2
12	Cylinder, double acting (for 6,000 lb. capacity unit)	B99-021-932	2

# TROUBLESHOOTING GUIDE - BHBD

Before performing any task, always lower the chute fully to the floor and disconnect the power supply.  
Consult factory for problems at time of installation, or for any problems not addressed below.

Problem	Possible Cause(s)	Action
1.) Power unit doesn't run when "UP" button is pressed.	<ul style="list-style-type: none"> <li>a. Transformer fuse is blown.</li> <li>b. No supply voltage.</li> <li>c. Upper-travel limit switch is engaged or bad.</li> <li>d. Bad connection in control circuit.</li> <li>e. Bad control transformer.</li> <li>f. Open motor relay coil.</li> <li>g. Battery voltage low (DC units)</li> </ul>	<ul style="list-style-type: none"> <li>a. Test with meter; replace if bad.</li> <li>b. Test with meter. Check fuses, breakers, and overloads to determine the cause.</li> <li>c. Inspect and test switch. Replace if bad.</li> <li>d. Test all parts of circuit with meter.</li> <li>e. Check for 24 VAC; replace if bad.</li> <li>f. Test with meter; replace if bad.</li> <li>g. Test with meter. Charge battery if low (is motor relay LED on?)</li> </ul>
2.) Motor runs properly, chute doesn't move. Motor and pump not noisy.	<ul style="list-style-type: none"> <li>a. Motor rotation is wrong.</li> <li>b. Pump has failed.</li> <li>c. Fluid level is low.</li> </ul>	<ul style="list-style-type: none"> <li>a. Verify motor shaft rotates CCW.</li> <li>b. Consult factory for replacement.</li> <li>c. Ensure reservoir is filled.</li> </ul>
3.) Motor or control enclosure hums, chatters, or buzzes, or some type or squeal can be heard; the chute does not move, or the chute moves only slowly.	<ul style="list-style-type: none"> <li>a. See (2b), for when chute doesn't raise.</li> <li>b. Excess voltage drop to motor, due to power wire size too small, wire run too long, or incoming voltage too low.</li> <li>c. Motor is "single-phasing".</li> <li>d. Pressure relief opening at full pressure.</li> <li>e. Contamination holding open the lowering valve or the check valve.</li> </ul>	<ul style="list-style-type: none"> <li>a. See section (2).</li> <li>b. Check power installation for adequacy. Check incoming voltage while motor is running. Correct problem if found.</li> <li>c. Determine cause of loss of voltage on one phase; correct.</li> <li>d. Check for structural damage or binding of the scissor legs, etc. Check for chute overload condition.</li> <li>e. Remove and inspect. Clean per instructions in this manual.</li> </ul>
4.) Chute raises, then drifts down.	<ul style="list-style-type: none"> <li>a. See section (3)</li> </ul>	<ul style="list-style-type: none"> <li>a. See section (3).</li> </ul>
5.) Chute lowers too quickly.	<ul style="list-style-type: none"> <li>a. See section (3)</li> <li>b. Flow control spool is stuck.</li> </ul>	<ul style="list-style-type: none"> <li>a. See section (3).</li> <li>b. See below.</li> </ul>
6.) Chute lowers too slowly.	<ul style="list-style-type: none"> <li>a. Flow control spool is stuck.</li> <li>b. Pinched hose.</li> <li>c. Velocity fuse locking (chute only slowly creeps down).</li> </ul>	<ul style="list-style-type: none"> <li>a. Remove plug from FC port; push on flow spool to ensure it is fully pressed into the cavity.</li> <li>b. Check pressure, supply, and return hose for kinks.</li> <li>c. Same as for jerky chute motion.</li> </ul>
7.) Chute won't lower.	<ul style="list-style-type: none"> <li>a. Velocity fuse locking.</li> <li>b. Control transformer fuse blown.</li> <li>c. No supply voltage.</li> <li>d. Valve solenoid is bad.</li> <li>e. Bad connection in control circuit.</li> <li>f. Physical blockage of the structure.</li> <li>g. Solenoid valve or suction hose screen plugged.</li> </ul>	<ul style="list-style-type: none"> <li>a. Same as for jerky chute motion.</li> <li>b. Test with meter; replace if bad.</li> <li>c. Test with meter. Check for cause of power loss.</li> <li>d. Check with multimeter on diodecheck function. (Reading for ohms will not provide an accurate test of the coil.)</li> <li>e. Test all parts of circuit with meter.</li> <li>f. Inspect for foreign material or objects that might block the leg set of its rollers.</li> <li>g. Remove and inspect. Clean per instructions in this manual.</li> </ul>
8.) Spongy or jerky chute motion.	<ul style="list-style-type: none"> <li>a. Excessive air in the hydraulic cylinders.</li> </ul>	<ul style="list-style-type: none"> <li>a. Bleed all per procedure described in this manual.</li> </ul>

# WARNING LABEL IDENTIFICATION

MAKE SURE ALL WARNING LABELS ARE IN PLACE!

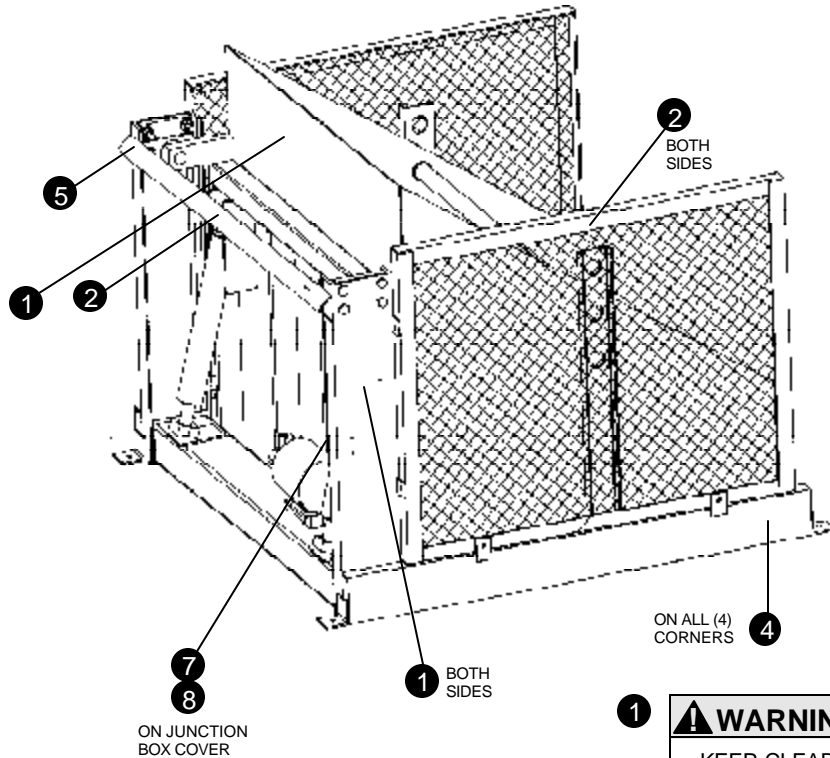

\*Product safety signs or labels should be periodically inspected and cleaned by the product users as necessary to maintain good legibility for safe viewing distance . . . ANSI 535.4 (10.21)  
Contact manufacturer for replacement labels if needed.

1	<b>WARNING</b>	<b>ADVERTENCIA</b>	<b>ATENCIÓN</b>
	KEEP CLEAR WHEN IN USE 220	MANTENGASE ALEJADO CUANDO SE ESTA OPERANDO	SE TENIR À DISTANCE LORS DU FONCTIONNEMENT

2	<b>WARNING</b>	<b>ADVERTENCIA</b>	<b>ATENCIÓN</b>
	KEEP CLEAR OF PINCH POINT 208	MANTENGASE ALEJADO DE PUNTO DE CORTE	SE TENIR À DISTANCE DU POINT DE PINCEMENT

4	<b>WARNING</b>	<b>ADVERTENCIA</b>	<b>ATENCIÓN</b>
	SECURE FRAME TO FLOOR 204	ASEGURE EL BASTIDOR AL PISO	FIXER SOLIDEMENT LE CADRE AU PLANCHER

7	<b>NOTICE</b>	<b>NOTA</b>	<b>AVIS</b>
	POWER SUPPLY: 115 Volt/1 Phase/60 HZ		
	CONTROL VOLTAGE: 24 VOLT AC		
	CORRIENTE: 115 Volt/1 Fase/60 HZ		
	VOLTAJE DE CONTROL: 24 VOLT CA		
ALIMENTATION ÉLECTRIQUE: 115 Volt/1 Phase/ 60 HZ			
VOLTAGE DE CONTRÔLE: 24 VOLT AC			
248			

ON HYDRAULIC TANK (NOT SHOWN)

8	<b>DANGER</b>	SHUT POWER OFF AND CONSULT OWNERS MANUAL BEFORE WORKING ON THIS EQUIPMENT
	<b>PELIGRO</b>	CORTE LA CONSULTE Y CONSULTE EL MANUAL DEL PROPIETARIO ANTES DE TRABAJAR EN ESTE EQUIPO
	<b>DANGER</b>	COUPER LE COURANT ET CONSULTER LE MANUEL D'UTILISATION AVANT DE TRAVAILLER SUR CET ÉQUIPEMENT
221		

9	<b>ISO AW-32</b>
	<b>HYDRAULIC OIL OR EQUIVALENT</b>
	<b>ACEITE HIDRÁULICO O EQUIVALENTE</b>
	<b>HYDRAULIQUE OU ÉQUIVALENT</b>
206	

---

# LIMITED WARRANTY

**ONE YEAR LIMITED WARRANTY.** The manufacturer warrants for the original purchaser against defects in materials and workmanship under normal use one year after date of purchase. (Not to exceed 15 months after date of manufacture.) Any part which is determined by the manufacturer to be defective in material or workmanship and returned to the factory, shipping costs prepaid, will be, as the exclusive remedy, repaired or replaced at our option. Labor costs for warranty repairs and/or modifications are not covered unless done at manufacturer's facilities. Any modifications performed without written approval of the manufacturer may void warranty. This limited warranty gives purchaser specific legal rights which vary from state to state.

**LIMITATION OF LIABILITY.** To the extent allowable under applicable law, the manufacturer's liability for consequential and incidental damages is expressly disclaimed. The manufacturer's liability in any event is limited to, and shall not exceed, the purchase price paid. Misuse or modification may void warranty.

**WARRANTY DISCLAIMER.** Our company has made a diligent effort to illustrate and describe the products shown accurately; however, such illustrations and descriptions are for the sole purpose of identification, and do not express or imply a warranty that the products are merchantable, or fit for a particular purpose, or that the products will necessarily conform to the illustrations or descriptions.

The provisions of the warranty shall be construed and enforced in accordance with the UNIFORM COMMERCIAL CODE and laws as enacted in the State of Indiana.

**DISPOSITION.** Our company will make a good faith effort for prompt correction or other adjustment with respect to any product which proves to be defective within the Limited Warranty. Warranty claims must be made in writing within said year.

---

## SERVICE RECORD

DATE OF SERVICE: ____/____/____
WORK DONE BY: _____
SERVICE PER- FORMED: _____
_____
_____

DATE OF SERVICE: ____/____/____
WORK DONE BY: _____
SERVICE PER- FORMED: _____
_____
_____

DATE OF SERVICE: ____/____/____
WORK DONE BY: _____
SERVICE PER- FORMED: _____
_____
_____

DATE OF SERVICE: ____/____/____
WORK DONE BY: _____
SERVICE PER- FORMED: _____
_____
_____

DATE OF SERVICE: ____/____/____
WORK DONE BY: _____
SERVICE PER- FORMED: _____
_____
_____

DATE OF SERVICE: ____/____/____
WORK DONE BY: _____
SERVICE PER- FORMED: _____
_____
_____