

BH-5 SERIES

HYDRAULIC DOCK LEVELER

OWNERS MANUAL

INSTALLATION – OPERATION
SERVICE – REPAIR PARTS



Beacon Industries, Inc.

12300 Old Tesson Rd. • St. Louis, MO 63128-2247 USA

Phone: (314) 487-7600 Fax: (314) 487-0100

www.beacontechology.com

E-Mail: sales@beacontechology.com

SECTION 1

INSTALLATION INSTRUCTIONS RECEIVING AND HANDLING

RECEIVING:

Check for possible damage or missing parts immediately upon receipt of unit. Note any damage on receiving papers.

Prepare any claims against carrier if necessary.

NOTE: Damage noticed after receipt must be reported to carrier within 15 days.

Notify **Beacon** of any damage or missing parts. Failure to do so within 15 days may result in loss of warranty coverage.

HANDLING:

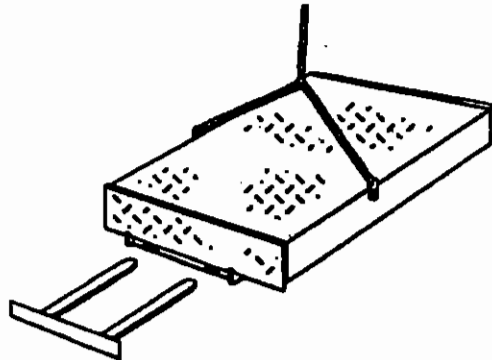

FIGURE A

Move leveler into position by using:

- chain sling inserted into upper side plate holes. (See Figure A) or
- fork lift, inserted into front fork slots;
- fork lift, inserted into rear fork slots just below the deck.

NOTE:

Two bumpers, and weather seals, if applicable, are strapped under leveler. Handle with care to avoid damage to these components. Contact for chain sling assembly (Part #1700)

SECTION 1

INSTALLATION INSTRUCTIONS INSTALLATION

INSTALLATION: (Consists of 3 phases)

Pit preparation

Leveler Preparation

Leveler Installation

PIT PREPARATION AND ELECTRICAL INSTALLATION:

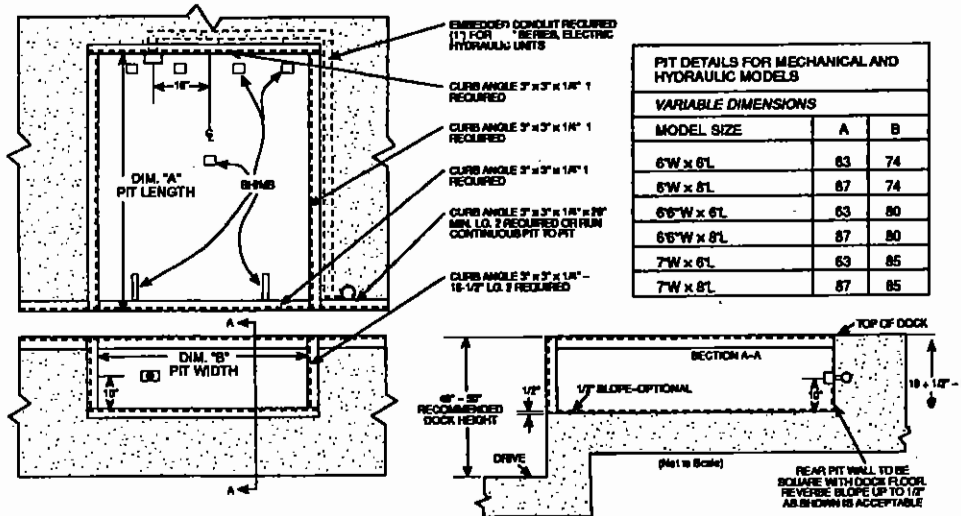

FIGURE B

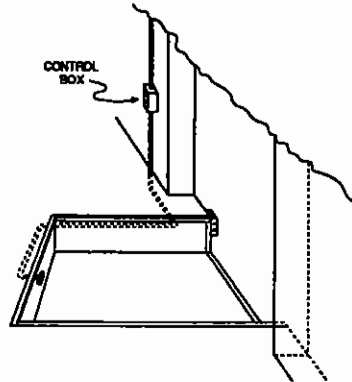

FIGURE C

1. Examine pit. Pit walls should be square and plumb. Clean all debris from pit.

2. Measure pit dimensions. (See Figure B for accurate dimensions.)

Verify that pit walls are:

- Square
- Plumb

Place shims in correct locations on pit floor before lowering leveler into place in pit.

[Pit depth at shim locations (minus 19") equals shims thickness.]

NOTE: Shims are to be placed directly under rear frame uprights, under base of cylinder, and under lip keepers. See Figure D, page 1 - 3.

3. Install control box on wall near pit. (See Figure C)

4. Install wire leads for motor and proximity sensors per wiring diagram. (See Troubleshooting section, page 4 - 1)

Wire must be installed through conduit. (Conduit to be supplied by customer.) Additional wire leads may be used to supply temporary power to leveler from control box.

LEVELER PREPARATION

1. Position leveler directly in front of pit.
2. Cut restraining band on lip.
3. Connect temporary wire leads to proper wire grouping at motor.
4. Check motor operation.
5. Check fluid level in hydraulic reservoir. Check all hydraulic hose connections and fittings.

NOTE: Unit may fail to operate correctly at this point if temporary power does not supply adequate voltage. **DO NOT** make adjustments to leveler. Provide proper voltage before attempting to operate leveler.

If unit does not raise when motor activates, rotation may be wrong. Recheck connections per wiring diagram to correct rotation.

Leveler should be in stored (home) position. Fluid should measure 3/4" below neck of plug. If necessary, fill to correct level, using Dextron II transmission fluid.

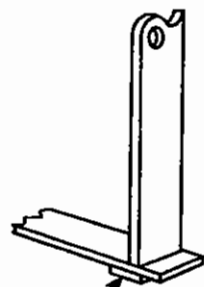

FIGURE D

SHIM UNDER
EACH UPRIGHTSHIM UNDER
LEFT & RIGHT
LIP KEEPER

FIGURE E

SECTION 1**INSTALLATION INSTRUCTIONS
LEVELER INSTALLATION****LEVELER INSTALLATION:**

1. Place leveler into pit opening.	Allow one inch (1") equal clearance between leveler sides and pit walls. Rear frame angle of leveler should be tight against and flush with rear curb angle for proper welding.
2. Recheck shim packs to ensure leveler is at proper height, flush with floor level, front and rear.	Shims must be placed properly under each rear frame upright, under cylinder and front lip keepers. (See Figure D , page 1 - 3 for close up view and Figure B, page 1 - 2 for shim locations.) Skip weld rear of leveler to curb angle and front shims to leveler and curb angle. (See Figure E, page 1 - 3.)
3. Bring deck section of leveler to fully raised position.	Use temporary power, or lift slowly with fork lift under lip edge.
4. Place maintenance strut securely under deck.	Remove strut from hanger bracket under right hand center of deck, rotate down to vertical position, and place in cup on frame.
5. Weld all shims securely in place.	
6. Connect permanent power source to control box on wall	
7. Make permanent electrical hook up to motor.	
8. Connect two (2) proximity switches through conduit to wall mounted control box. (See electrical diagram, page 4 - 1)	Leveler should now be ready to operate.

SECTION 1

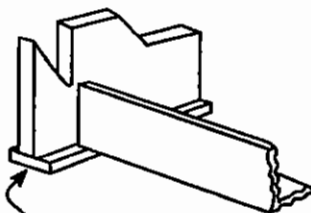
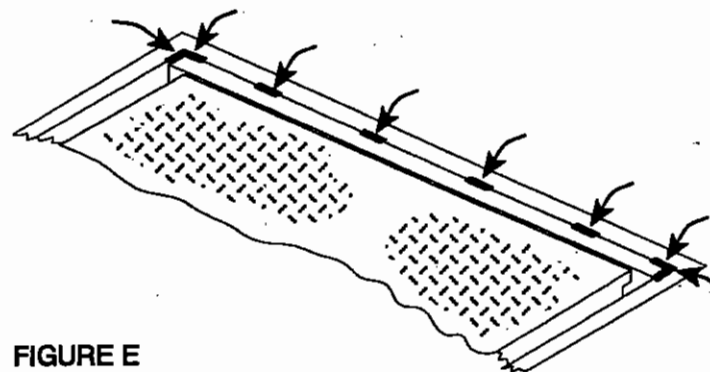
INSTALLATION INSTRUCTIONS
LEVELER INSTALLATION

9. Close control box and activate leveler until lip fully extends.	Be sure selector switch on control box is set to NORMAL mode.
10. Store maintenance strut.	Two person operation. One person holds pressure on OPERATE button while a second person stores the maintenance strut. Do not hold pressure on OPERATE button for more than 10 seconds.
11. Allow leveler to complete cycle, descending to stored position.	Release OPERATE button. Leveler will drift down to below dock, automatically restart, rise several inches above dock while lip is closing, then turn off and store in home position.
12. Operate leveler through each of its complete cycles to check for proper operation. (See pages 2 - 1 through 2 - 4, Normal and Below Dock Operation.)	Cycles include ABOVE DOCK cycle, and BELOW DOCK cycle. Allow one minute between cycles while testing.
13. Recheck all hydraulic hose connections and fittings.	Make sure all fittings are snug and no leaks are present.
14. Install bumpers on dock face.	Flat steel inside edge must be flush with pit side wall and angle side away from pit. Bumpers should be flush with dock floor or 48" off ground. Raised bumpers should be supported to floor from behind.
15. Complete weld at rear of leveler.	Weld to cover approximately 50% of the length of the rear angle. Ensure welds are placed directly behind frame uprights: (4 each on 6' wide models, 6 each on 7' wide models) and at ends of angle. (See Figure E, page 1 - 3)

LIP EXTENDED FOR ABOVE DOCK USE
SELECTOR SWITCH IN NORMAL MODE

1. Press and hold the OPERATE button on the control box.

Release the button when the platform raises and the lip fully extends.

With optional LIP OUT button:

1. Press and hold OPERATE button. When lip edge is above truck floor level, also press LIP OUT button. Platform will stop and lip will extend. Release OPERATE and LIP OUT buttons simultaneously.

NOTE: For drawing of optional LIP OUT valve, see page 4 - 7.

2. The platform will descend with lip extended until lip rests on truck bed.

The leveler allows for up and down movement of truck during loading or unloading.

3. When truck departs, the leveler automatically recycles to stored, cross traffic position, employing the recycle proximity sensor shown below.

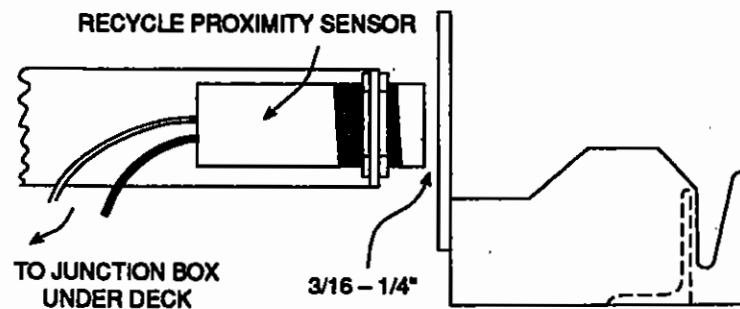

FIGURE F

SECTION 2

**OPERATING INSTRUCTIONS
NORMAL RECYCLE PROCEDURE**

RECYCLE PROCEDURE WITH TRUCK AT DOCK:

1. Press and hold the OPERATE button.

Hold the button until the platform partially raises and lip is fully withdrawn from truck.

2. Release the OPERATE button.

Leveler will descend to stored, cross traffic position.

SECTION 2

**OPERATING INSTRUCTIONS
BELOW DOCK OPERATION**

LIP EXTENDED ONTO TRUCK FOR UNLOADING BELOW DOCK:

1. Turn selector switch to NORMAL mode.

2. Press and hold the OPERATE button.

Wait until the platform raises and the lip fully extends.

With optional LIP OUT button, simply allow leveler to rise above floor of truck, then also press LIP OUT button. Deck will stop and lip will extend.

3. Release the OPERATE button (*and optional LIP OUT button.*)

4. Turn the selector switch from NORMAL to BELOW DOCK mode while leveler is descending.

Leveler will settle to truck floor as low as 12" below dock to service very low trucks without recycling.

LIP RETRACTED FOR END LOADS BELOW DOCK:

1. Turn selector button to BELOW DOCK mode.
2. Press and hold the OPERATE button.

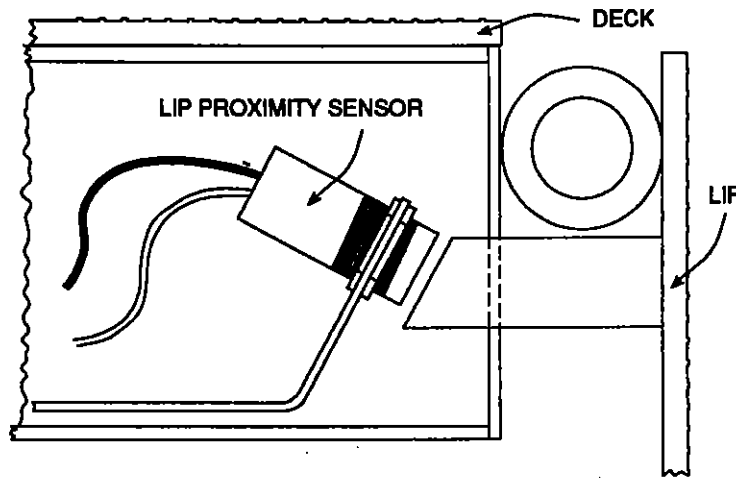

FIGURE G

Hold the button down until the platform raises and the lip partially extends.

The motor will automatically shut off when the lip is out of range of the lip tab proximity sensor. (See illustration, opposite.)

The leveler will descend to its fully lowered position with the lip between truck and dock face.

NOTE: The leveler will not automatically recycle in this position. (See recycle procedure.)

FOR PLACING LIP ON TRUCK TO CONTINUE LOADING OR UNLOADING

1. Turn selector switch to NORMAL mode.
2. As leveler begins to rise, press and hold the OPERATE button.

Leveler will automatically begin to recycle to stored position.

Allow the platform to raise and lip to fully extend, then release OPERATE button.

Leveler will descend until lip rests on truck floor. When truck departs the unit will automatically recycle.

SECTION 2

**OPERATING INSTRUCTIONS
BELOW DOCK RECYCLE PROCEDURE (CONTINUED)**

RETURN LEVELER TO STORED POSITION FROM BELOW DOCK:

1. Turn selector switch to **NORMAL** mode.

Leveler will automatically return to stored, cross traffic position.
Do not push **OPERATE** button.

RECYCLE PROCEDURE FROM BELOW DOCK:

(Unit does not recycle from this [dead] position when truck departs.) If hit while extended, the lip will yield to impact.

1. Turn selector switch to **NORMAL** mode.

Leveler will now return to its stored, cross traffic position automatically, before or after truck departs.

SECTION 2

**OPERATING INSTRUCTIONS
AUTOMATIC SAFETY STOP**

AUTOMATIC SAFETY STOP

If lip of leveler should become unsupported while a load of 1,000 pounds or greater is on the platform, the hydraulic system automatically locks the platform in position, supporting the load.

To restore the leveler to normal operation:

1. Remove the load.
2. Press and release the **OPERATE** button. Leveler should drift downward and recycle.

SECTION 3

MAJOR COMPONENTS

HYDRAULIC FLUID CONTENT	Levelers are shipped filled with Dextron II automatic transmission fluid.
ELECTRICAL Motor:	1 HP, TEFC No. 56 frame, 15 minute duty cycle
Control Panel:	Wall mounted metal box (12" X 10" X 5 1/4"), Meets N.E.M.A. 12, hinged cover for easy access
Proximity Sensor Controls:	Automatic Recycle Function, Below Dock Lip Control, 2 each Model 8036A, Square D

MOTOR VOLTAGE (AC)	PHASE	AMP DRAW (RUNNING)	POWER (amperage) REQUIREMENT
115	1	15.0	30
230	1	7.2	20
208-220-240	3	3.6	10
440-460-480	3	1.8	10

1 HP, 1 ph motor draws 25 amps to start motor.
 To avoid voltage drop, recommends #10 wire on short runs and #8 wire on long runs.
 Consult code requirements.

CAUTION: A MOTOR CAN BURN OUT FOR ANY OF THE FOLLOWING REASONS:

1. Hook up to incorrect line voltage.
2. Single phasing of polyphase motor caused by a blown fuse or loss of one leg of electrical supply.
3. Low voltage to motor due to insufficient line capacity. This is most common with 110V, 1 ph operation.

This equipment is shipped from the factory fully tested and operative.

The majority of operating problems are caused by **IMPROPER VOLTAGE** or **UNNECESSARY ADJUSTMENT BY UNQUALIFIED PERSONNEL!**

To comply with warranty, contact your local representative or call the factory direct if you are experiencing difficulty with the leveler during the warranty period. Do not risk voiding the warranty by tampering with the equipment.

CAUTION:

Always place maintenance strut and disconnect power before climbing under or placing hands under leveler.

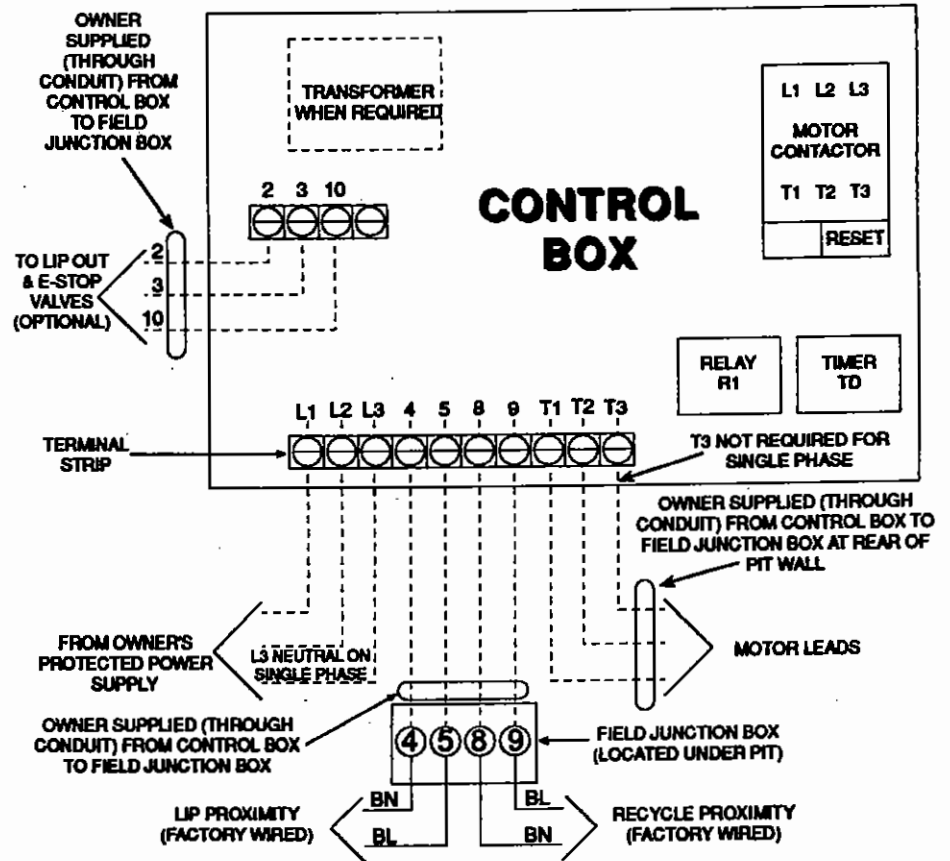

FIGURE H

SYMPTOM:	PROBABLE CAUSE:	CORRECTION:
RAMP WILL NOT RAISE FROM STORED POSITION: Motor not running in NORMAL mode when OPERATE button is pressed	1. Incorrect or disconnected electrical hook-up.	1. Review wiring diagram and check connections.
	2. Blown fuses or open circuit breaker.	2. Replace bad fuses. Reset circuit breakers. Determine and correct other electrical problems.
	3. Loss of line voltage.	3. Check lines and repair if necessary.
	4. Open overload relays on motor starter in control panel.	4. Allow to cool. Push "RESET" button located in control box.
	5. Burned motor.	5. Determine cause of burn-out. Correct problem. Replace motor. (Contact factory.)

SYMPTOM:	PROBABLE CAUSE:	CORRECTION:
<p>RAMP WILL NOT RAISE FROM STORED POSITION:</p> <p>Motor not running in BELOW DOCK mode when OPERATE button is pressed.</p>	<p>1. Lip proximity switch out of adjustment.</p>	<p>1. To check proximity adjustment:</p> <p>Place selector switch in NORMAL mode. Press and hold OPERATE button until unit is fully raised.</p> <p>Place maintenance strut.</p> <p>Push and release OPERATE button in short repetitions until lip closes.</p>
	<p>2. Lip proximity switch has loose wire.</p>	<p>2. Reconnect wire, if loose. Check junction box under leveler and terminal strip in control box.</p>

SYMPTOM:	PROBABLE CAUSE:	CORRECTION:
<p>RAMP WILL NOT RAISE OR LIP WILL NOT EXTEND FULLY:</p> <p>Motor running or humming in NORMAL mode</p> <p>(1 ph motor)</p>	<p>1. Voltage drop, probably due to insufficient line capacity, resulting in blown fuses, tripped circuit breakers or motor hum.</p>	<p>1. Test voltage at motor starter with motor running. Test for amperage drain. (Low voltage/high amperage indicates inadequate feed line for distance of run.) Replace feed line with adequate wire size.</p>
<p>(3 ph motor)</p>	<p>2. Wrong rotation.</p>	<p>2. Reverse T1 and T3 at terminal strip. (See Figure H, page 4 - 1.)</p>
<p>(3 ph motor)</p>	<p>3. Motor single-phasing.</p>	<p>3. Check for bad fuse or loss of power in one line due to loose connections or tripped breakers or overloads.</p>
<p>(1 ph or 3 ph motor)</p>	<p>4. Load on ramp.</p>	<p>4. Remove the load. Ramp is not designed to lift more than its own weight.</p>
<p>(1 ph or 3 ph motor)</p>	<p>5. Low fluid</p>	<p>5. Refill if needed. Check fittings and hoses and tighten if loose.</p>
<p>(1 ph or 3 ph motor)</p>	<p>6. Motor or pump physically damaged.</p>	<p>6. Replace.</p>
<p>RAMP WILL NOT AUTOMATICALLY RETURN FROM BELOW DOCK:</p> <p>Unit in BELOW DOCK mode</p>	<p>1. Unit is not designed to automatically return when selector is in BELOW DOCK mode.</p>	<p>1. Return switch to NORMAL position. Unit will now automatically recycle and store at floor level.</p>

SYMPTOM:	PROBABLE CAUSE:	CORRECTION:
<p>RAMP WILL NOT LOWER AFTER BEING FULLY RAISED:</p>	<p>1. Physical obstruction.</p>	<p>1. Check and remove. (Always use maintenance strut for safety.)</p>
	<p>2. Safety stop in hydraulic fittings has locked up.</p>	<p>2. Push and release the OPERATE button to unlock and allow the unit to descend. If symptom persists, consult factory.</p>
<p>LIP SAGS WHILE UNIT IS DESCENDING TO TRUCK:</p> <p>OR</p> <p>RAMP EXPERIENCES LONG DELAY BEFORE RAISING:</p>	<p>1. Air in hydraulic system.</p>	<p>1. While unit is descending with lip extended, switch selector to BELOW DOCK mode. When unit has reached bottom, push lip down. Now lift and drop the lip four times. Check lip sag by operating in NORMAL mode. If sag persists, consult factory.</p>
<p>RAMP WILL NOT RETURN AUTOMATICALLY WHEN TRUCK DEPARTS</p> <p>Motor not running, in NORMAL mode</p> <p>Motor humming in NORMAL mode</p>	<p>1. Recycle proximity switch out of adjustment or has loose wire.</p> <p>2. Insufficient line voltage</p>	<p>1. To store unit: Push and hold the OPERATE button until the lip closes and deck raises approx. 5" above floor.</p> <p>Release button. Unit will store.</p> <p>To check adjustment, raise unit in NORMAL mode until lip extends. As unit is descending, switch to BELOW DOCK mode. Unit will fully descend with lip extended.</p> <p>Refer to Figure F, proximity sensor adjustment, page 2 - 1, or reconnect wire, if loose.</p> <p>2. See symptom 1 at top of page 4 - 4. (Motor running or humming in NORMAL mode)</p>

ITEM	DESCRIPTION
1	LIP PLATE ASSEMBLY, 16"
2	HINGE PIN—LIP
3	DECK REAR HINGE KIT
4	DECK CYL. W/ HARNESS PINS & CLEVIS KEYS
5	PINS & KEYS, DECK CYLINDER
6	LIP CYLINDER W/ PINS & CLEVIS KEYS
7	PINS & KEYS, LIP CYLINDER
8	HOSE ASSEMBLY, DECK CYLINDER TO LIP 28" CYLINDER
9	HOSE ASSEMBLY, PUMP TO DECK CYLINDER 31"
10	HOSE ASSEMBLY, PUMP TO LIP CYLINDER 40"
11	PROXIMITY SENSOR; DECK RECYCLE
12	PROXIMITY SENSOR; LIP, BELOW DOCK
13	FULL RANGE TOE GUARDS
14	MOTOR & PUMP ASSEMBLY

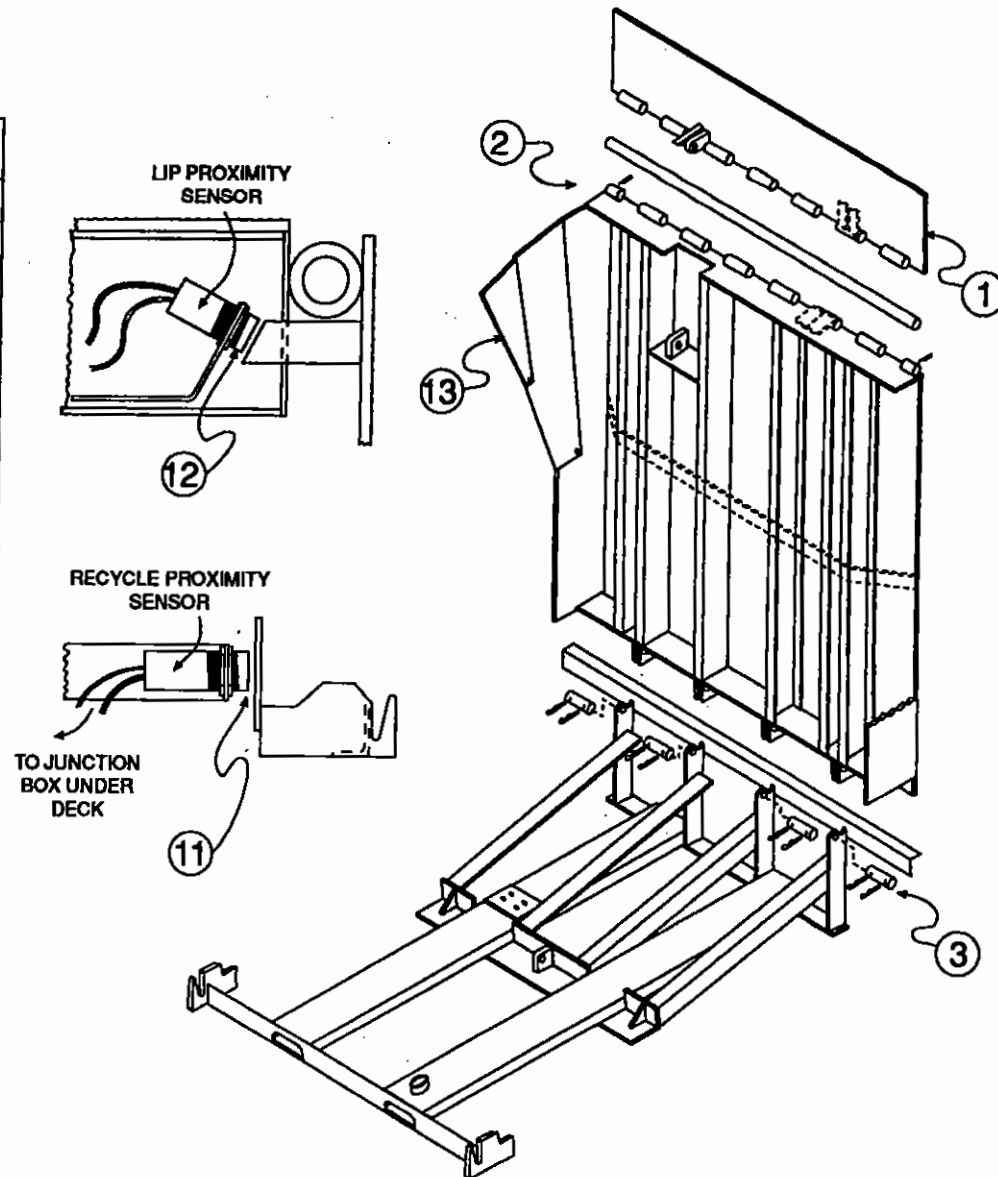

FIGURE I

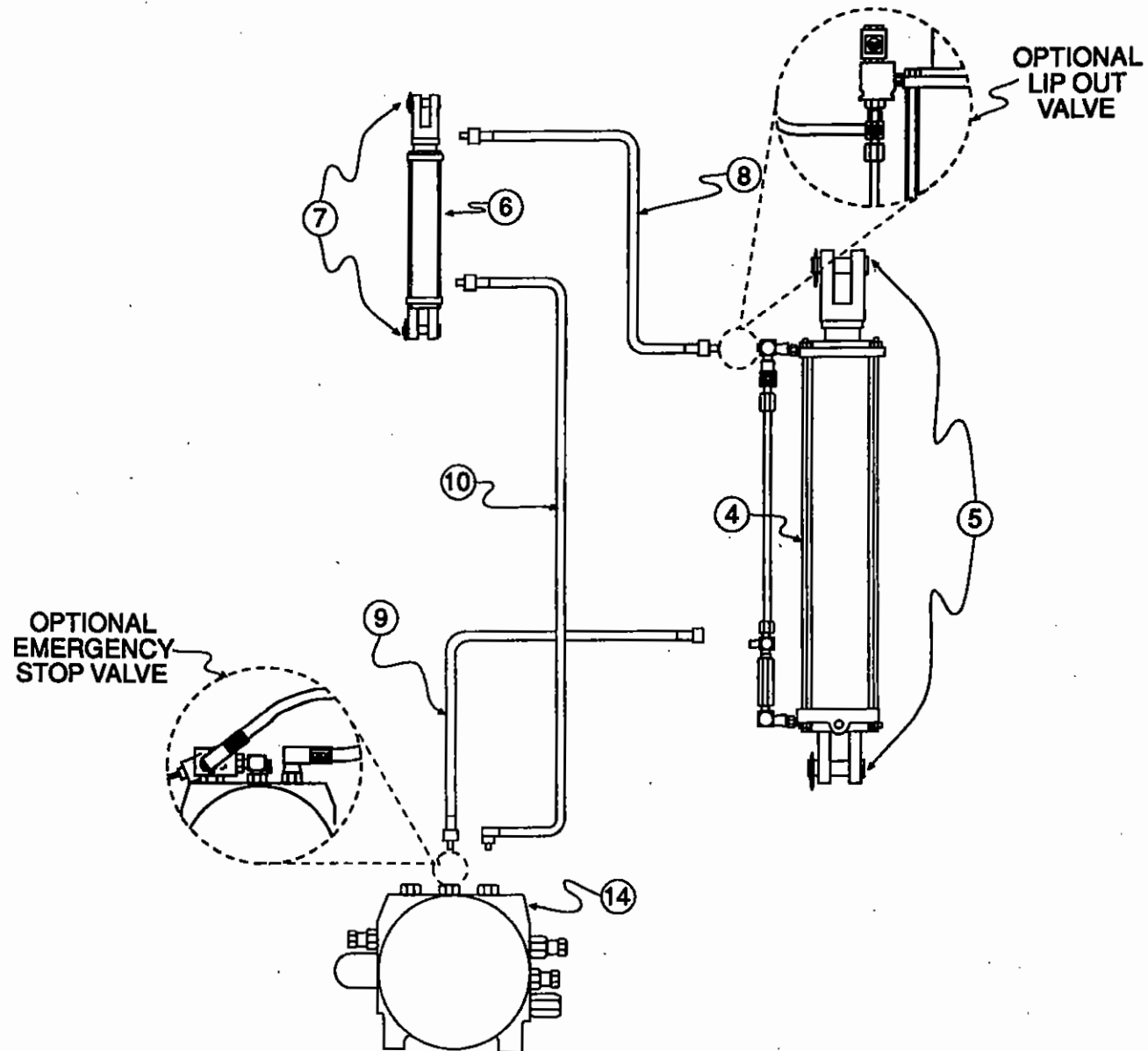

FIGURE J

**BEACON BH5 HYDRAULIC DOCK LEVELER
BELOW DOCK OPERATING PROCEDURES**

1. Press the operate button and let the unit rise and the lip extend fully.
2. Release the button and then turn the switch to below position while the unit is lowering.
3. To return back to the parked position turn the switch back to normal. The unit will auto return to the night locks.

5.1 Beacon Industries, Inc. Limited Warranty

Beacon Industries, Inc. warrants that this BH5 Series Dock Leveler will be free from defects in design, materials and workmanship on all structural parts for a period of exactly five (5) years from date of shipment. All claims for breach of this warranty must be made within thirty (30) days after the defect is or can, with reasonable care, be detected and in no event more than five (5) years after shipment. This warranty is extended to the original purchaser of this product and is non transferable.

Beacon warrants that this BH5 Series Dock Leveler will be free from defects in design, materials and workmanship on all hydraulic parts for a period of exactly five (5) years from date of shipment. All claims for breach of this warranty must be made within thirty (30) days after the defect is or can, with reasonable care, be detected and in no event more than three (3) years after shipment.

Beacon warrants that this BH5 Series Dock Leveler will be free from defects in design, materials and workmanship on all electrical parts for a period of exactly one (1) year from date of shipment. All claims for breach of this warranty must be made within thirty (30) days after the defect is or can, with reasonable care, be detected and in no event more than one (1) year after shipment.

In order to be entitled to the benefits of this warranty, the unit must have been properly installed, maintained, operated within its capacity, and not otherwise abused. Ninety (90) day periodic maintenance and adjustment is the sole responsibility of the owner.

This warranty is Beacon's exclusive expressed warranty.

Beacon expressly disclaims all implied warranties including the implied warranties of merchantability and fitness.

In the event of any defects covered by this warranty, Beacon will remedy such defects by repairing or replacing any defective equipment or parts, bearing all of the costs for parts, from Beacon to site. This shall be the exclusive remedy for all claims whether based on contract, negligence, or strict liability. **Beacon shall not, in any event, be liable for any loss of the use of any equipment or incidental or consequential damages of any kind.**

5.1 Beacon Industries, Inc. Limited Warranty Cont'd.

Maintenance and validation by original purchaser is required to keep Warranty in effect. In order to keep this Warranty in effect, the original purchaser must do two things:

First: The original purchaser must have the BH5 Series Dock Leveler maintained and serviced as prescribed in the Owner's Manual.

Second: The original purchaser must present the seller with a maintenance schedule to show that the BH5 Series Dock Leveler has been maintained and serviced in accordance with the Beacon's Owner's Manual. The validated maintenance schedule must be submitted whenever a claim is made under this Warranty.

Items not covered by Warranty. The seller does not cover:

(i) Defects, damage or deterioration due to normal use, wear and tear or exposure; (ii) normal maintenance services; (iii) the replacement of service items, i.e., fluid; (iv) damage or defects due to misuse, water damage, electrical power supply surges, improper installation, alteration, negligence or accident; and (v) damage or defects due to the repair of the BH5 Series Dock Leveler by someone other than an authorized dealer or the installation of parts other than genuine Beacon part.

No other warranties made. This Warranty is in lieu of all other express or implied warranties of The Beacon BH5 Series Dock Leveler, the manufacturer and the selling dealer, including any implied warranty of merchantability or fitness for any particular purpose. Neither Beacon Industries, Inc. assumes, or authorizes any person to assume, on its behalf, any other obligation or liability.

Some states do not allow the exclusion on limitation of implied warranties or liability for incidental or consequential damages, so the above limitations or exclusions may not apply to you.

This Warranty and, any and all claims that may arise shall be construed according to the laws of the State of Missouri, USA.