

BED & BBL SERIES

MECHANICAL EDGE OF DOCK LEVELER

OWNERS MANUAL

**INSTALLATION • OPERATION
SERVICE • REPAIR PARTS**



Beacon Industries, Inc.

12300 Old Tesson Rd. • St. Louis, MO 63128-2247 USA

Phone: (314) 487-7600 Fax: (314) 487-0100

www.beacontechnology.com

E-Mail: sales@beacontechnology.com

SECTION 1

INSTALLATION INSTRUCTIONS RECEIVING AND HANDLING

RECEIVING:

Check for possible damage or missing parts immediately upon receipt of unit. Note any damage on receiving papers.

Prepare any claims against carrier if necessary.

NOTE: Damage noticed after receipt must be reported to carrier within 15 days.

Notify "Manufacturer" of any damage or missing parts.

HANDLING:

Unit is easily handled for installation by hooking a heavy chain to each buttonhead rivet.

INSTALLATION INSTRUCTIONS INSTALLATION

GENERAL INFORMATION:

Edge of Dock Levelers are designed to service trailers 5" above to 5" below dock level.

The dock levelers are shipped banded without tension on spring. Adjustment should be accomplished when installed.

Prior to installation, clean the dock face and dock area.

All prepunched holes are 13/16" diameter. Use 4" to 6" x 3/4" anchor bolts.

SECTION 1

INSTALLATION INSTRUCTIONS INSTALLATION

Illustration: 1

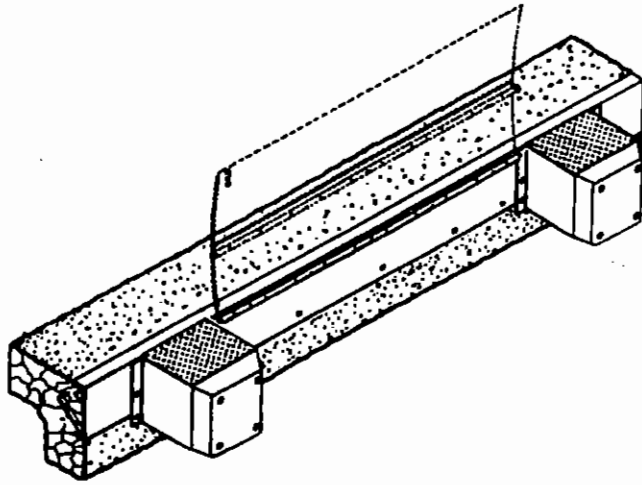
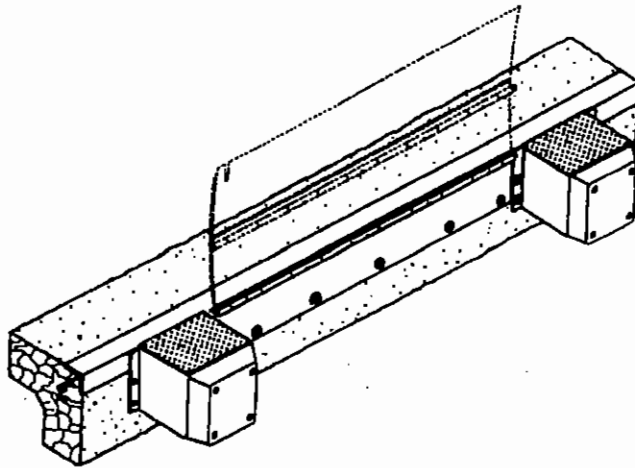

Illustration: 2



WELD ON—NEW CONSTRUCTION

Use when dock edge vertical steel is 8" or wider. At dock edge, mark the center of chosen leveler location. Mark dock edge 33" either side of center (36" for 72" models; 39" for 78" models; 42" for 84" models).

Locate leveler with top of rear hinge flush with top of dock. This will place top of base plate approx. 1/4" below dock surface.

Tack weld ends of base plate to dock face steel, the top edge of base plate being 1/4" below dock. Tack weld both bump blocks at left and right ends of leveler allowing 1/4" space for weld between base plate ends and bump block.

Continuous weld bump blocks and base plate along top and all vertical edges while holding leveler firmly against dock. Disregard prepunched holes.

WELD ON/BOLT ON—EXISTING CONSTRUCTION

Use when dock edge steel is securely anchored, but not adequate for weld-on method.

Complete all steps of instruction under "Weld On—New Construction."

Bolt leveler and bump blocks to dock face using all 13/16" prepunched holes furnished.

Illustration: 3

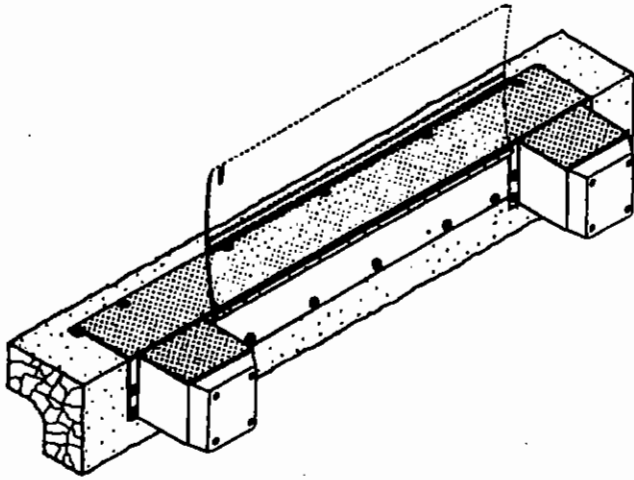
**BOLT ON + APPROACH PLATE — EXISTING CONSTRUCTION**

Use when dock edge has no steel, or steel is poorly anchored, and dock face is adequate for bolting. Mark and drill holes for dock leveler centered 6-1/4" below dock edge; base plate to be raised 1/8" above dock edge for welding to approach plate. Install two (2) anchor bolts in end holes, position leveler on bolts and partially tighten nuts to hold leveler secure.

Place approach plate in position on floor, front edge being 1/8" behind base plate. Mark floor along rear edge of approach plate.

Slide plate forward 2", tack weld to leveler and use as a guide for cutting groove in floor along entire width (long dimension) of approach plate. Groove to be 2" wide and 1/8" deeper than thickness of approach plate.

Break plate loose from leveler. Position approach plate in groove and tack weld to leveler base plate. Drill holes in floor using plate holes as guide. Install anchor bolts in plate (See General Information page 1-1). Weld and grind bolt heads to approach plate to a smooth dome shape. **Continuous weld** approach plate to top of base plate. Complete bolting phase of unit.

SECTION 1

INSTALLATION INSTRUCTIONS INSTALLATION

Illustration: 4

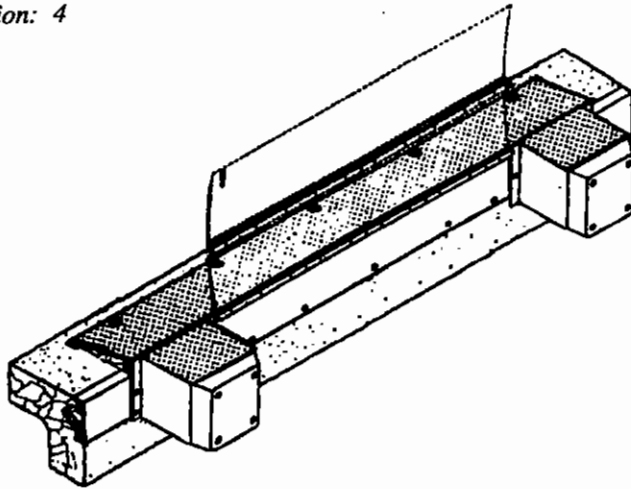

WELD ON AND RAISE APPROACH PLATE

Use when dock edge is sound but height is less than adequate (bolting may also be required). At dock edge, mark the center of chosen leveler location. Mark dock edge 33" either side of center (36" for 72" models; 39" for 78" models; 42" for 84" models).

Raise leveler and bump blocks to desired height (3" max.), and weld back of base plate to dock edge steel. Tack weld both bump blocks at left and right ends of leveler allowing 1/4" space for weld between base plate ends and bump block.

Cut groove in floor, position approach plate at top edge of base plate and tack weld to unit and bump blocks. (See Illustration 3 for details.)

Complete bolting phase of installation, then **continuous weld** all points of contact between leveler, dock steel and approach plate.

Illustration: 5

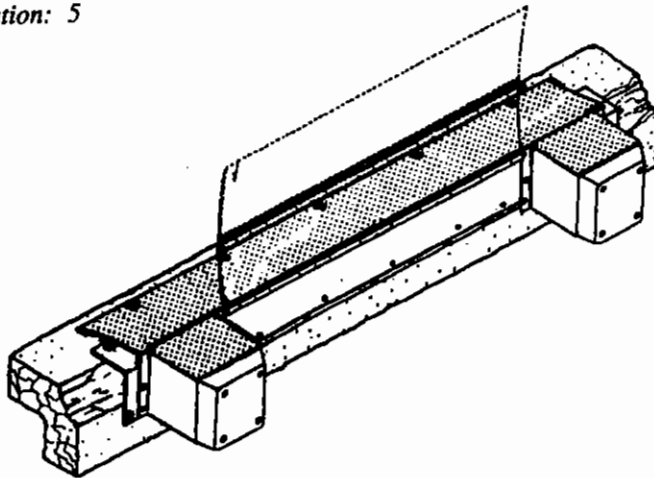

FORMED ANGLE-WELD ON—RAISED APPROACH PLATE

Use when dock edge is badly crumbled and dock edge is slightly low.

Unit must be raised approximately 2" in this application!

Position formed angle at desired location, mark holes, remove angle, drill holes and install angle. Install unit and approach plate according to methods described for "Existing Construction" (See Illustrations 3 & 4).

SECTION 1

INSTALLATION INSTRUCTIONS INSTALLATION

BARLIFT MODELS

After installation of EOD and Bumpers is completed, remove bolt from lifting bar, insert bar into bracket (handle facing forward) and reattach bolt.

SECTION 2

MAINTENANCE

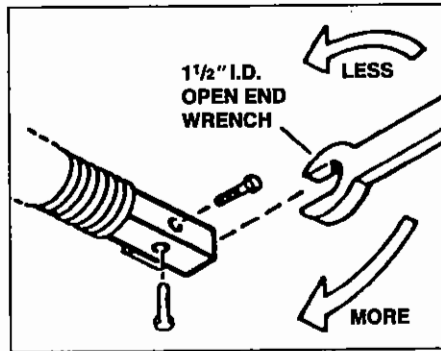

ADJUSTING TENSION ON RAMP

Units are shipped with no tension on ramp. After dock leveler is installed, adjust tension as follows:

1. Loosen the two set screws in spring winding assembly.
2. Place 1-1/2" wrench on square tubing and rotate tubing toward you approximately 1/4 turn. Hold tube in this position and tighten set screws.
3. Test the unit for lifting ease. Repeat steps 1 and 2 as necessary to provide easy lifting.

LUBRICATION PROCEDURE

For proper operation of your dock leveler, cleaning and lubrication should be performed every 90 days. Lubricate prior to attempting to adjust your leveler.

SECTION 3

OPERATING INSTRUCTIONS EDGE OF DOCK

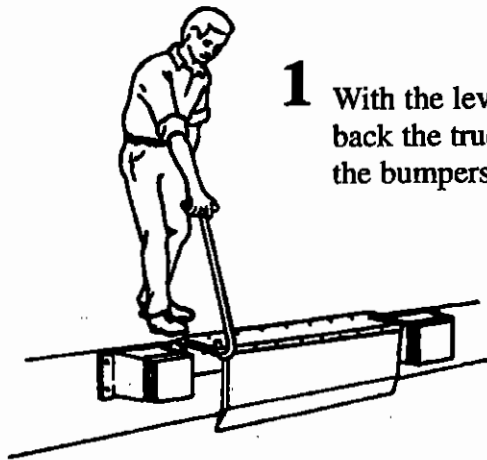

- 1** With the leveler in the stored position, back the truck into position against the bumpers.

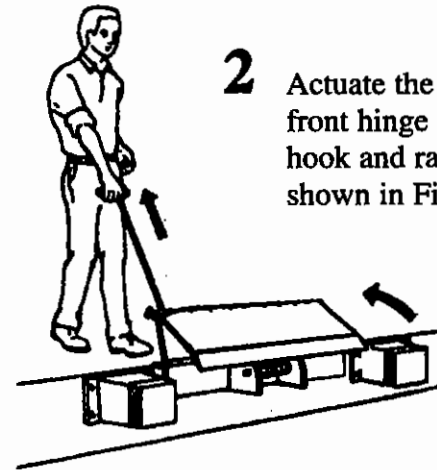

- 2** Actuate the leveler by hooking the front hinge rivet with the lifting hook and raising the leveler as shown in Fig. 2.

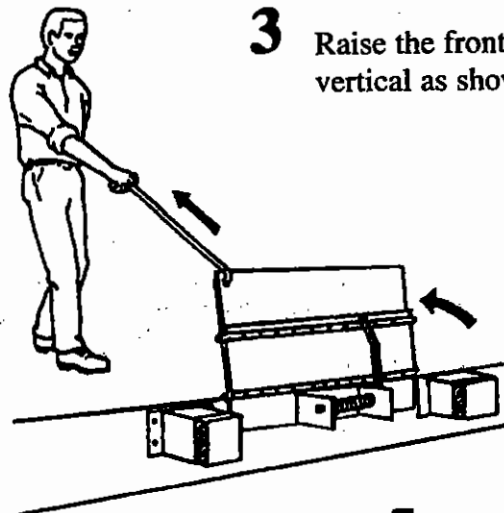

- 3** Raise the front plate (lip) to vertical as shown in Fig. 3.

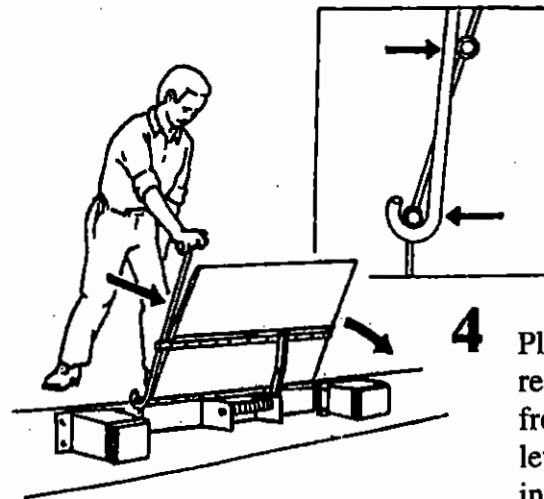

- 4** Place the lifting hook on the rear hinge pin and behind the front hinge rivet and push the leveler into the truck as shown in Fig. 4.

- 5** When the truck departs the leveler automatically returns to the stored position.

SECTION 3

OPERATING INSTRUCTIONS BAR LIFT EDGE OF DOCK

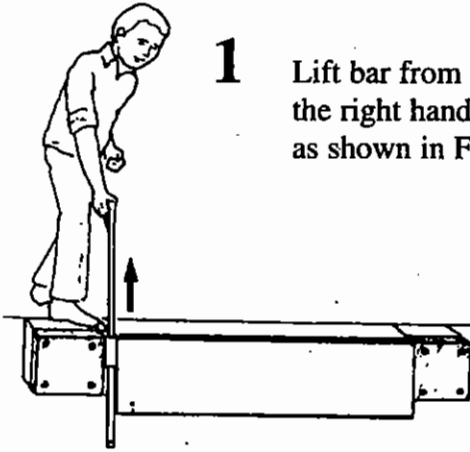

- 1** Lift bar from the stored position on the right hand side below the deck, as shown in Fig. 1.

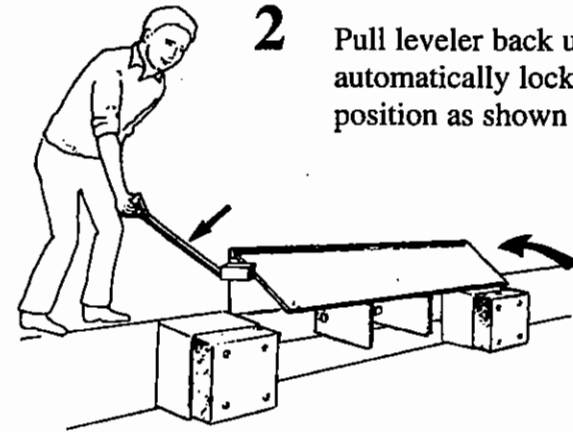

- 2** Pull leveler back until it automatically locks in raised position as shown in Fig. 2.

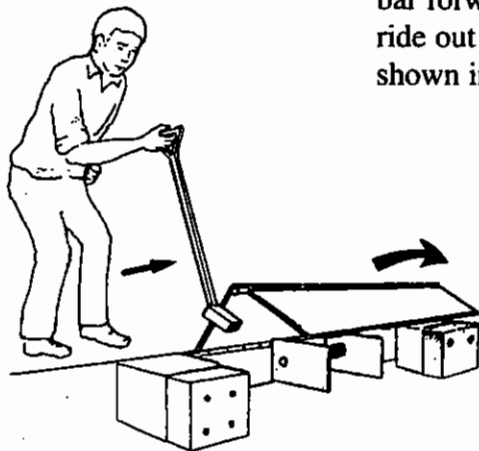

- 3** Using the bar as a lever, push the bar forward, allowing the lip to ride out onto the truck bed, as shown in Fig. 3.

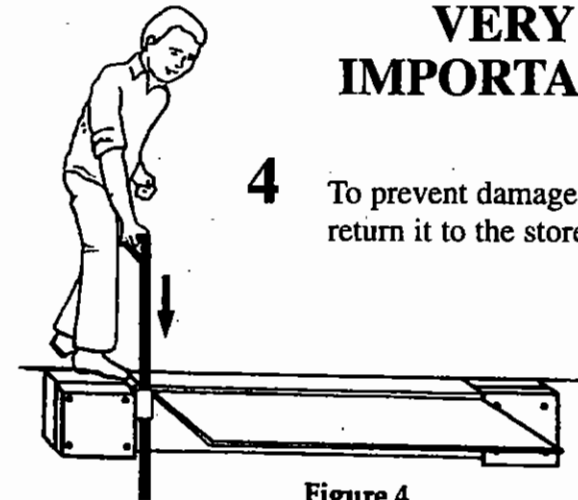

**VERY
IMPORTANT!**

- 4** To prevent damage to the bar, return it to the stored position.

Figure 4

SECTION 4

PARTS LIST EDGE OF DOCK

Item #	Model Description	ED66K	ED66M17	ED66MH	ED72K	ED72MH	ED72M17	PO66M	PO72M
1	Lip Plate Assy.	1684	175	179	1686	0724	297	185	1767
2	Lip Hinge Pin	115	115	115	189	189	189	115	189
3	Rivet (2 ea. for ea. pin)	188	188	188	188	188	188	188	188
4	Center Plate Assy.	153	153	180	183	737	183	186	1768
5	Base Plate Assy.	1683	151	151	1685	184	184	151	184
6	Base Hinge Pin	116	116	116	189	189	189	116	189
7	Torsion Spring	111A	111A	111A	111A	111A	111A	111A	111A
8	Winding Assy. —Assy.								
9	Torsion Arm & Linkage Assy.	149	149	149	149	149	149	149	149
10	Gusset w/Bearing	1688	156	156	1688	156	156	156	156
11	Bearing, Torsion Arm	128	128	128	128	128	128	128	128
12	Gusset w/Retainer	1687	157	157	1687	157	157	157	157
13	Gusset		107	107		107	107	107	107
14	Lip Tab	122	122	122	122	122	122	815	815
15	Lip Linkage Arms (2 ea. req.)	123	123	123	123	123	123	814	814
16	Linkage Pins (2 Ea. req.)	193	193	193	193	193	193	193	193
17	Linkage Pin Keys (2 ea. req.)	235	235	235	235	235	235	235	235
18	Molded Cord Rubber (4x12x13)	137	137	137	137	137	137	137	137
19	Bump Block Steel w/Cover	138	138	138	138	138	138	138	138
	Bump Blk Assy. (opt. 18")	208	208	208	208	208	208	208	208
20	Bump Block Assembly	139	139	139	139	139	139	139	139
21	Lifting Hook	141	141	141	141	141	141	141	141
22	Adapter Kit Assy. ED66M/ED72M	192	192	192	192	192	192	192	192

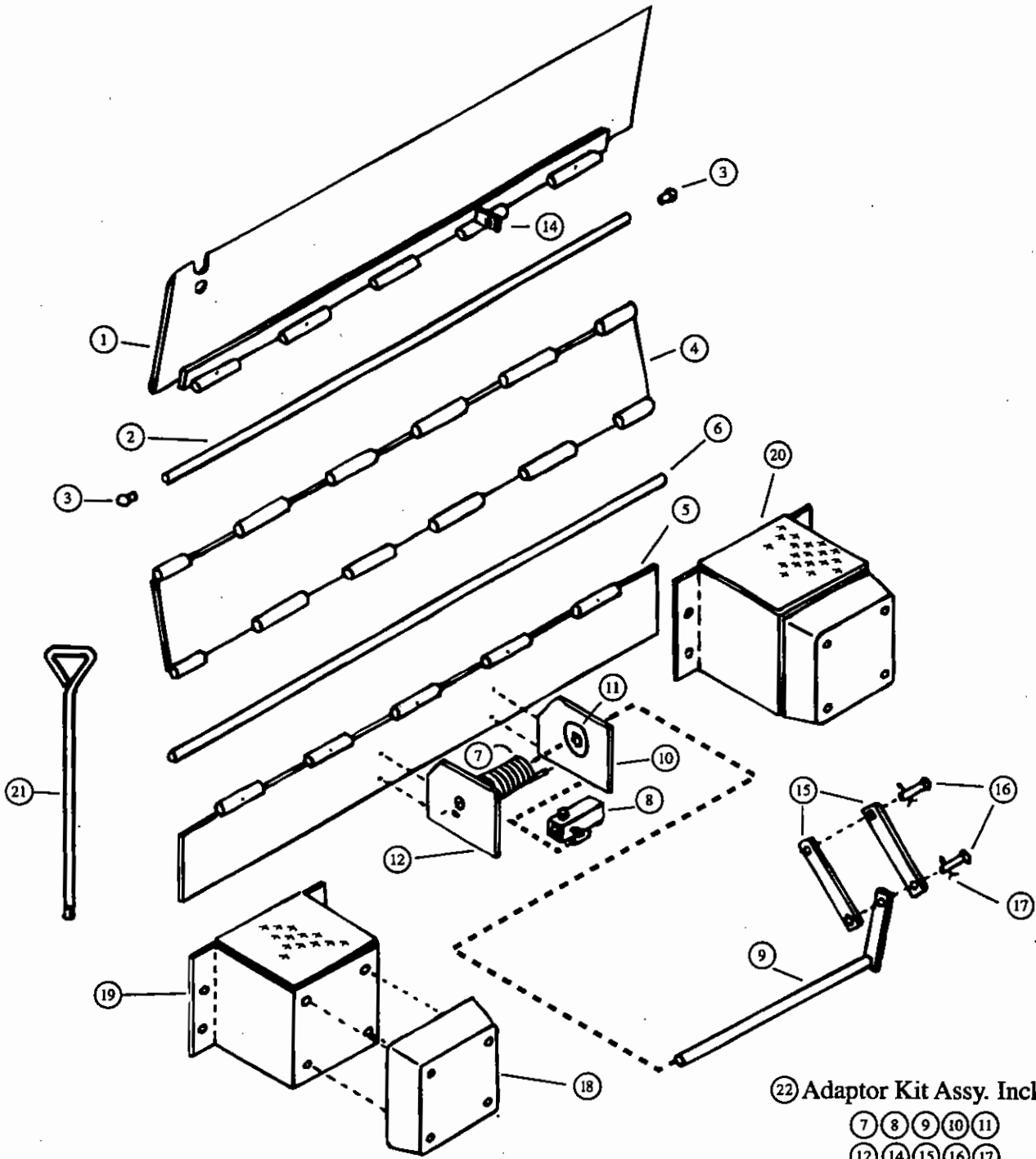

⑮ Linkage arms connect to ⑭ tab

⑳ Adaptor Kit Assy. Includes:

- ⑦ ⑧ ⑨ ⑩ ⑪
- ⑫ ⑬ ⑭ ⑮ ⑯ ⑰

SECTION 4

PARTS LIST BAR LIFT EDGE OF DOCK

Item #	Model Description	BL66K	BL72K	BL6617	BL7217	BL66H	BL72H
1	Lip Plate Assy.	1684	1686	175	297	179	724
2	Lip Hinge Pin	115	189	115	189	115	189
3	Rivet (2 ea. for ea. pin)	188	188	188	188	188	188
4	Center Plate Assy.	153	183	153	183	180	737
5	Base Plate Assy.	1683	1685	151	184	151	184
6	Base Hinge Pin	116	189	116	189	116	189
7	Torsion Spring	111A	111A	111A	111A	111A	111A
8	Winding Assy. —Assy.						
9	Torsion Arm & Linkage Assy.	149	149	149	149	149	149
10	Gusset w/Bearing	1688	1688	156	156	156	156
11	Bearing, Torsion Arm	128	128	128	128	128	128
12	Gusset w/Retainer	1687	1687	157	157	157	157
13	Gusset			107	107	107	107
14	Lip Tab	122	122	122	122	122	122
15	Lip Linkage Arms (2 ea. req.)	123	123	123	123	123	123
16	Linkage Pins (2 Ea. req.)	193	193	193	193	193	193
17	Pin Keys (3 ea. req.)	235	235	235	235	235	235
18	Molded Cord Rubber (4x12x13)	137	137	137	137	137	137
19	Bump Block Steel w/Cover	138	138	138	138	138	138
20	Bump Block Assembly	139	139	139	139	139	139
	Bump Blk. Assy. (opt. 18")	208	208	208	208	208	208
21	Bar Lift Handle Assembly	1726	1726	1726	1726	1726	1726
22	Bar Lift Holder Assembly	1725	1725	1725	1725	1725	1725
23	Lip Linkage Tabs (2 ea. req.)	445	445	445	445	445	445
24	Lip Kickout Bar	446	446	446	446	446	446
25	Lip Release Tab/Kickout Bar Guide (2 ea. req.)	1405	1405	1405	1405	1405	1405
26	Lip Stop Tab	503	503	503	503	503	503
27	Lip Kickout Pin	251	251	251	251	251	251
	Bar Lift Conversion Kit w/Push Over			[—No. 453 & 1727, All Models—]			
28	Kick Out Bar Guide	1017	1017	1017	1017	1017	1017

SECTION 4

PARTS DIAGRAM BAR LIFT EDGE OF DOCK

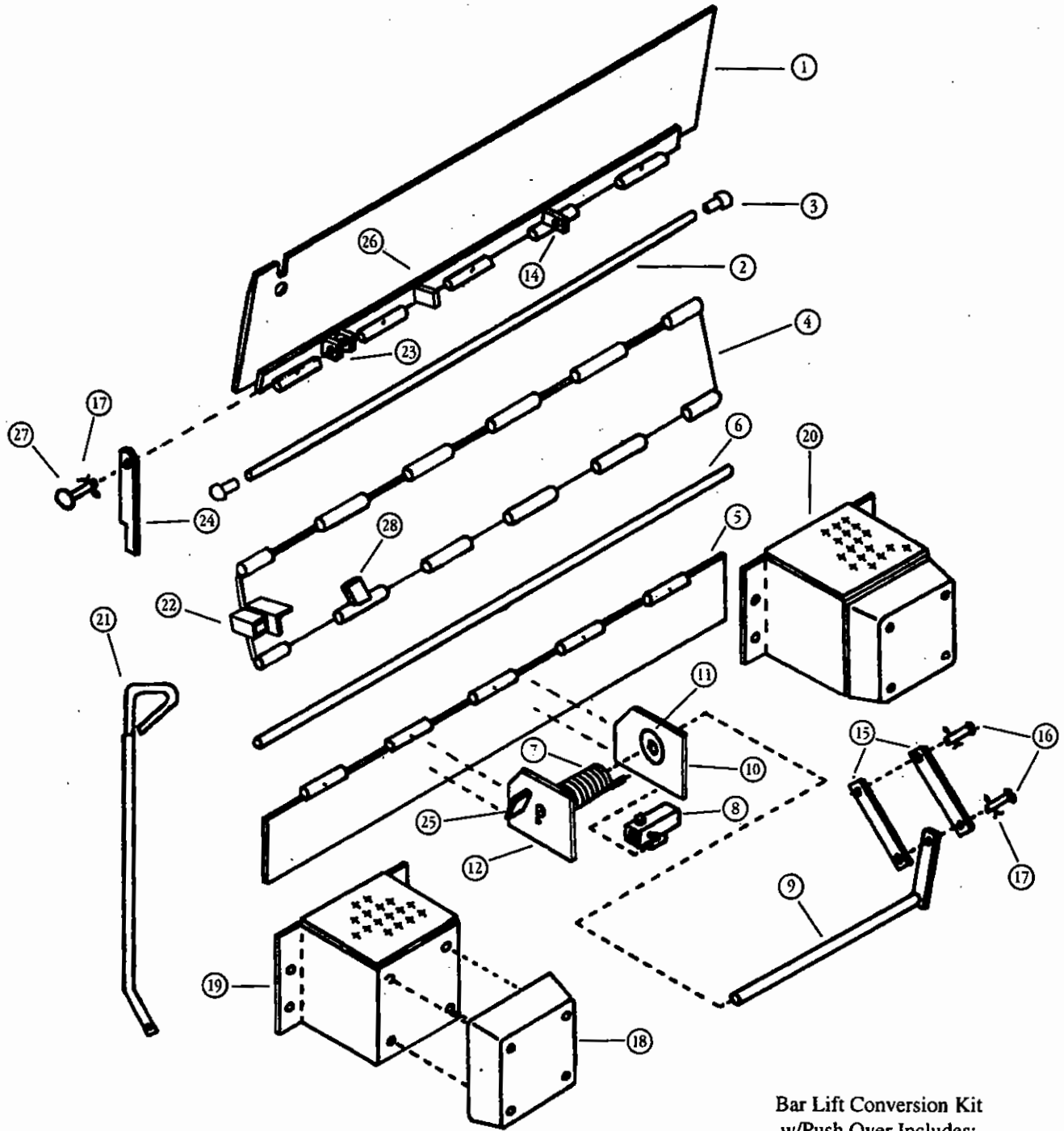

⑮ Linkage arms connect to ⑭ tab

Bar Lift Conversion Kit
w/Push Over Includes:

- ⑰ ⑳ ㉑ ㉒ ㉓ ㉔
- ㉕ ㉖ ㉗ ㉘

SECTION 4

PARTS LIST & DIAGRAM ADAPTOR KIT ASSEMBLY — EOD66

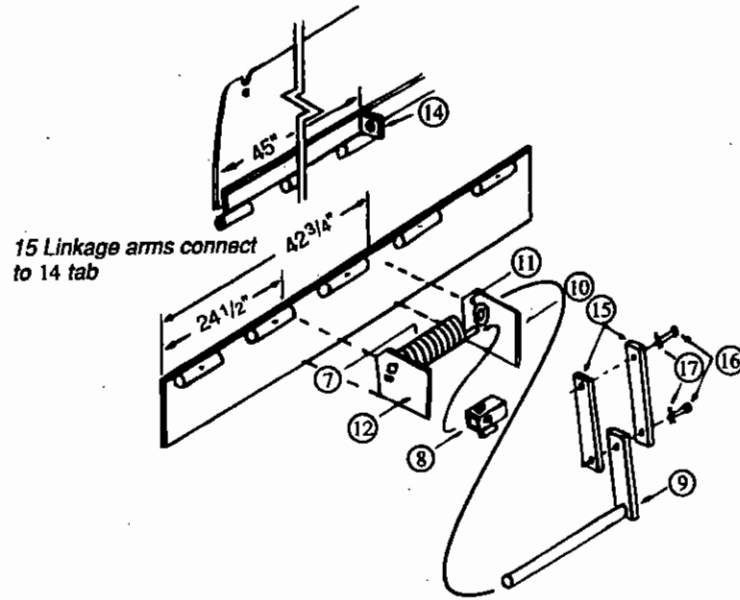

ADAPTOR KIT ASSEMBLY — EOD66

ED66M Kit, Part #192, consists of the following:

ITEM	DESCRIPTION
7	Torsion Spring
8	Spring winding tube assy.
9	Torsion arm & linkage assy.
10	Gusset with bearing
11	Bearing, torsion arm
12	Gusset with retainer
14	Lip linkage tab
15	Lip linkage arms (2 ea. req.)
16	Linkage pins (2 ea. req.)
17	Cotter Keys (2 ea. req.)

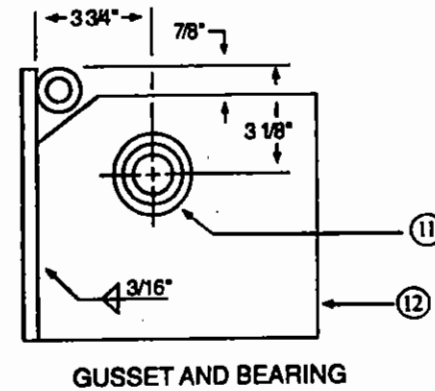
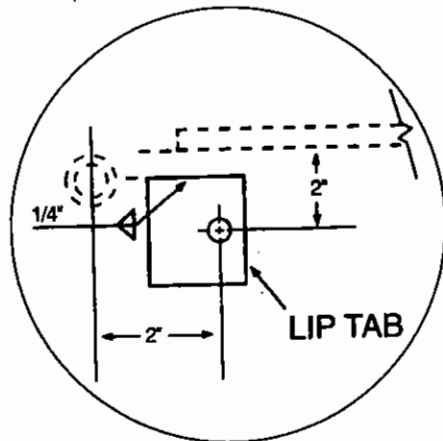

5.1 Beacon Industries, Inc. Limited Warranty

Beacon Industries, Inc. warrants that this BED AND BBL Series Manual Edge Of Dock -Dock Leveler will be free from defects in design, materials and workmanship on all structural parts for a period of exactly two (2) years from date of shipment. All claims for breach of this warranty must be made within thirty (30) days after the defect is or can, with reasonable care, be detected and in no event more than two (2) years after shipment. This warranty is extended to the original purchaser of this product and is non transferable.

In order to be entitled to the benefits of this warranty, the unit must have been properly installed, maintained, operated within its capacity, and not otherwise abused. Sixty (60) day periodic maintenance and adjustment is the sole responsibility of the owner.

This warranty is Beacon's exclusive expressed warranty.

Beacon expressly disclaims all implied warranties including the implied warranties of merchantability and fitness.

In the event of any defects covered by this warranty, Beacon will remedy such defects by repairing or replacing any defective equipment or parts, bearing all of the costs for parts, from Beacon to site. This shall be the exclusive remedy for all claims whether based on contract, negligence, or strict liability. **Beacon shall not, in any event, be liable for any loss of the use of any equipment or incidental or consequential damages of any kind.**

Maintenance and validation by original purchaser is required to keep Warranty in effect. In order to keep this Warranty in effect, the original purchaser must do two things:

First: The original purchaser must have the BED AND BBL Series Manual Edge Of Dock -Dock Leveler maintained and serviced as prescribed in the Owner's Manual.

Second: The original purchaser must present the seller with a maintenance schedule to show that the BED AND BBL Series Manual Edge Of Dock -Dock Leveler has been maintained and serviced in accordance with the Beacon's Owner's Manual. The validated maintenance schedule must be submitted whenever a claim is made under this Warranty.

Items not covered by Warranty. The seller does not cover:

(i) Defects, damage or deterioration due to normal use, wear and tear or exposure; (ii) normal maintenance services; (iii) the replacement of service items, i.e., fluid; (iv) damage or defects due to misuse, water damage, electrical power supply surges, improper installation, alteration, negligence or accident; and (v) damage or defects due to the repair of the BED AND BBL Series Manual Edge Of Dock -Dock Leveler by someone other than an authorized dealer or the installation of parts other than genuine Beacon part.

5.1 Beacon Industries, Inc. Limited Warranty Cont'd.

No other warranties made. This Warranty is in lieu of all other express or implied warranties of The Beacon BED AND BBL Series Manual Edge Of Dock -Dock Leveler, the manufacturer and the selling dealer, including any implied warranty of merchantability or fitness for any particular purpose. Neither Beacon Industries, Inc. assumes, or authorizes any person to assume, on its behalf, any other obligation or liability.

Some states do not allow the exclusion on limitation of implied warranties or liability for incidental or consequential damages, so the above limitations or exclusions may not apply to you.

This Warranty and, any and all claims that may arise shall be construed according to the laws of the State of Missouri, USA.